



Monitoring Lasers and their Upgrade

Ren-yuan Zhu

Caltech

September 27, 2010



CMS PbWO₄ ECAL Resolution

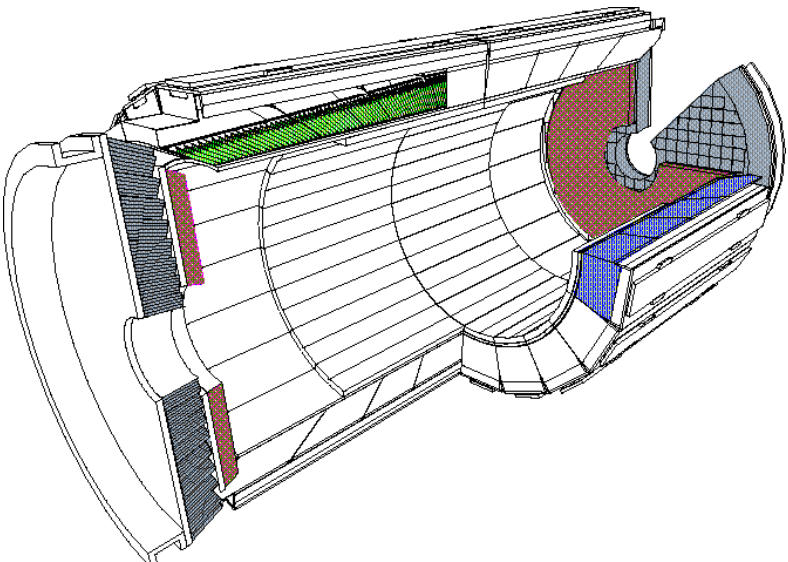

- 75,848 PbWO₄ crystals
- To maintain 0.5% constant term in energy resolution, the monitoring precision is required to be 0.2%.

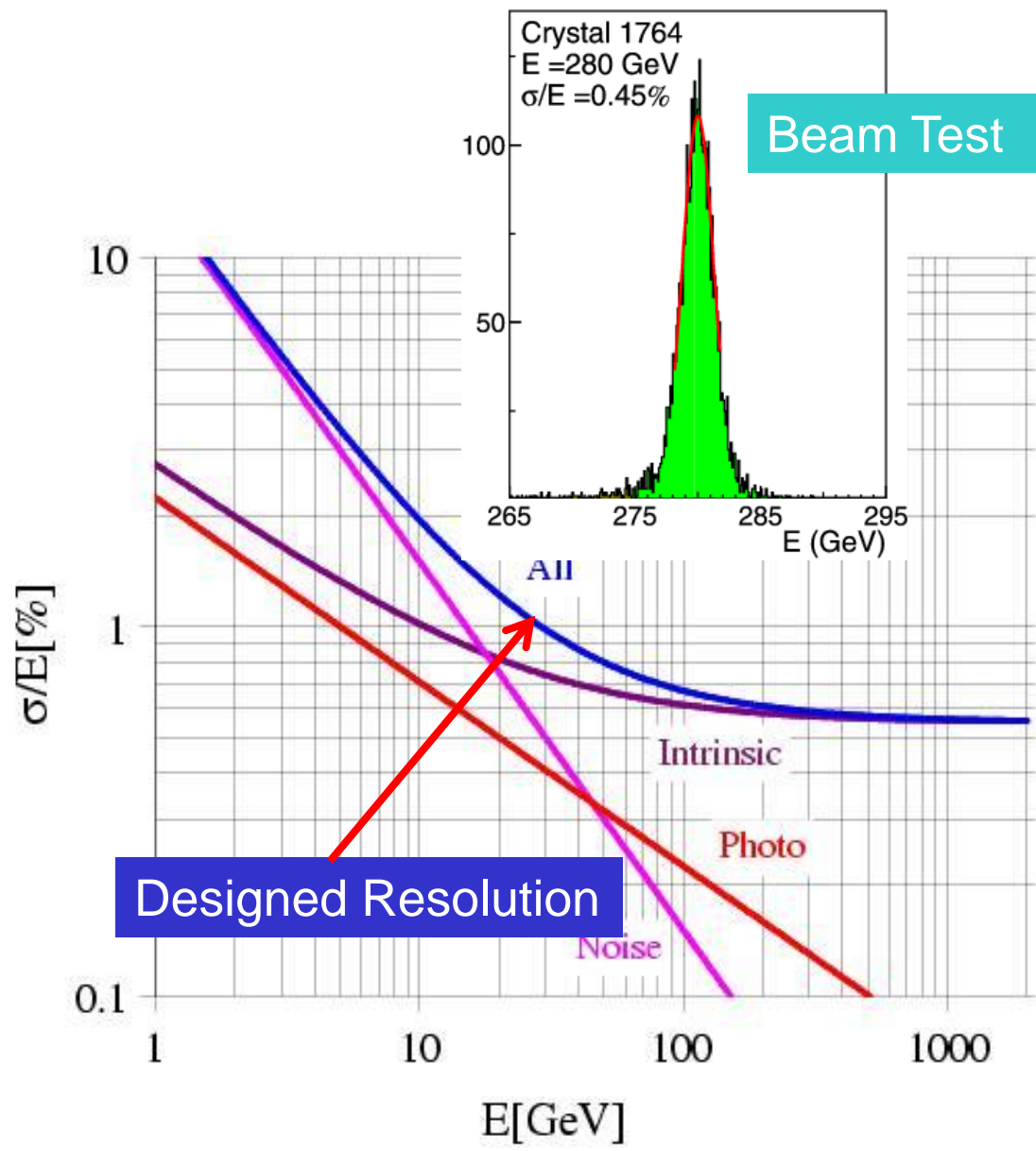

$\delta LO/LO$ versus $\delta LT/LT$ @ 100 rad/h

Strong correlation observed between variations of the light output and the longitudinal transmittance for full size $PbWO_4$ crystals in multi cycles of irradiation and recovery

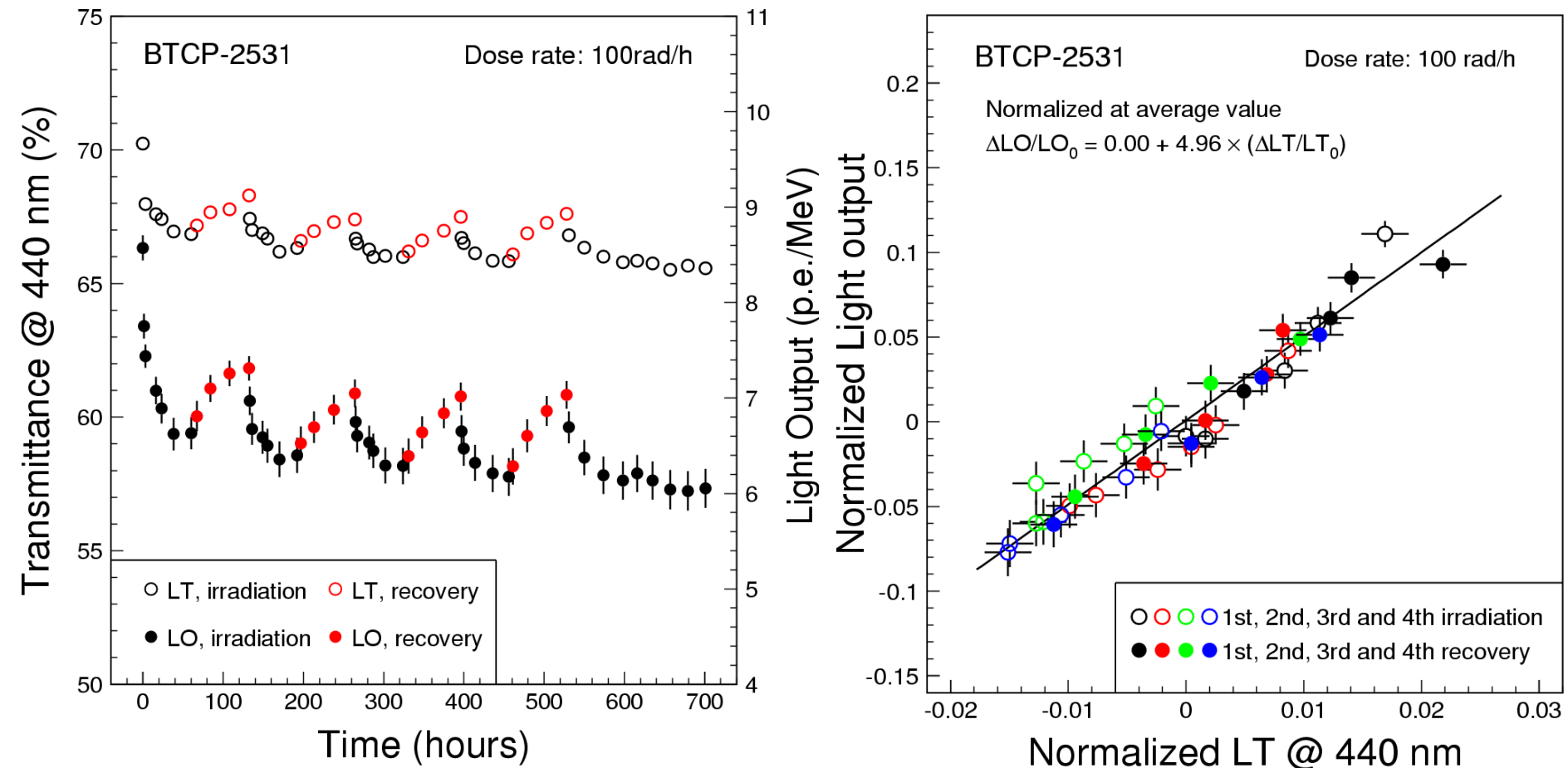



Continuous Monitoring *in situ*



Using 1% beam gaps (100 Hz) in the LHC beam structure

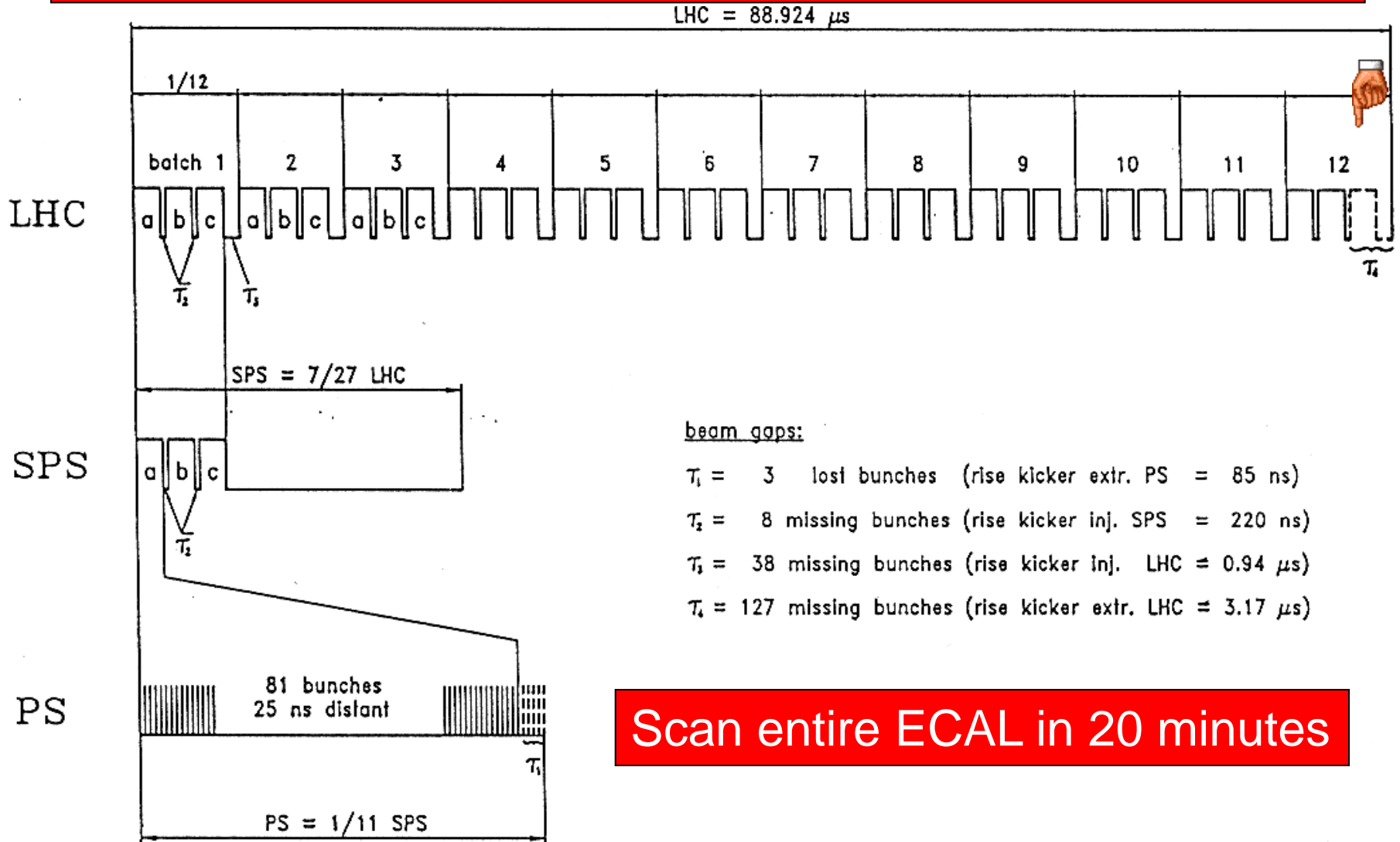

Scan entire ECAL in 20 minutes



Laser Light Monitoring System



Two lasers to guarantee 100% availability of 440 nm

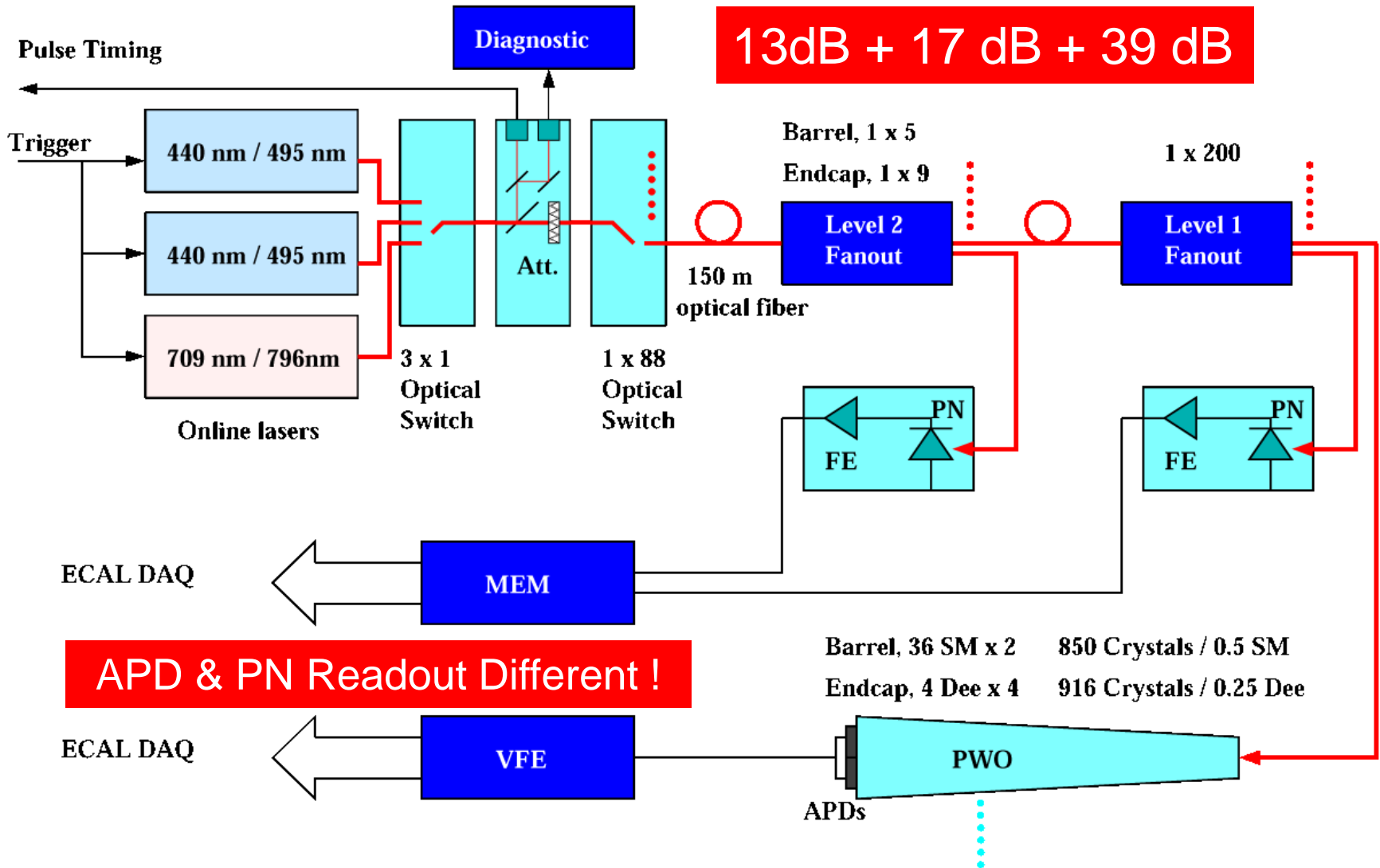



Laser System Commission at CERN



Each laser system contains an Nd:YLF pump laser and a tunable Ti:Sapphire laser with dual wavelengths

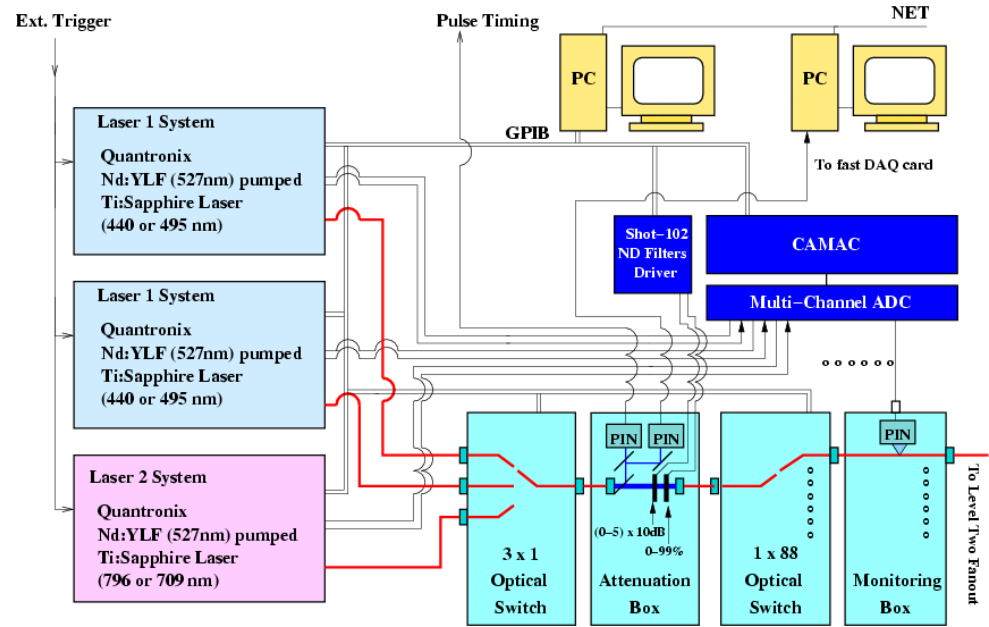
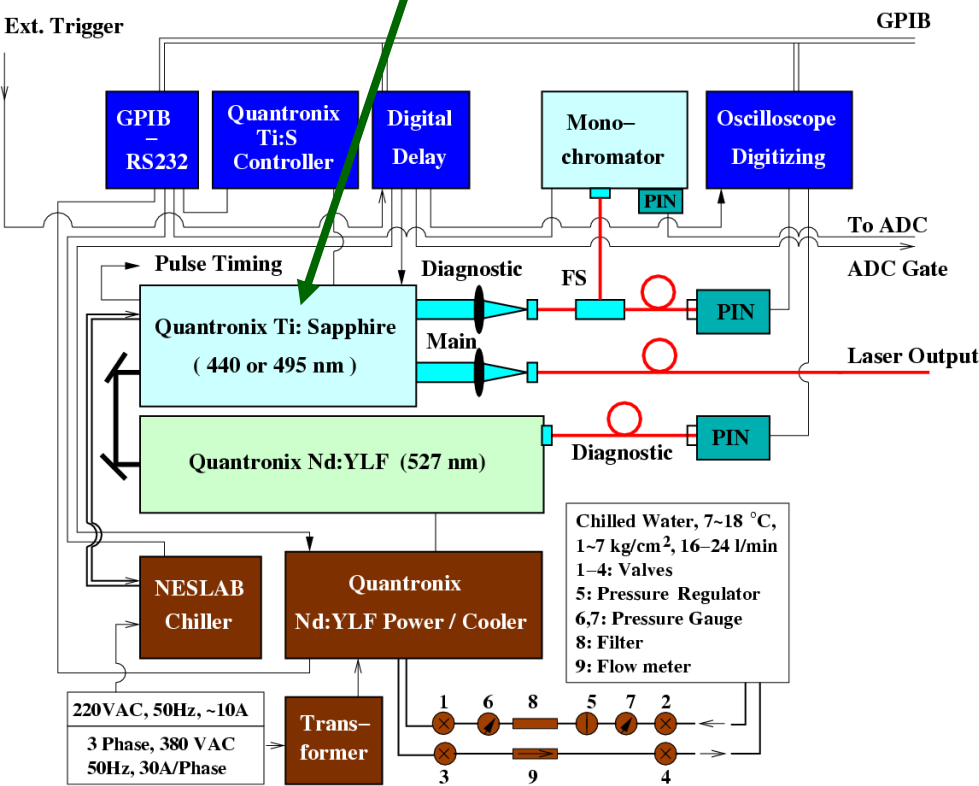

1st laser at H4: 8/2001
2nd & 3rd at H4: 8/2003
Software feedback: 5/2006
Two lasers at P5: 3/2007
All at P5: 3/2008



Laser Specifications in TDR



- Pulse FWHM: < 40 ns to match ECAL readout
- Pulse jitter: < 3 ns for synchronization with LHC
- Pulse rate: ~ 100 Hz, scan of full ECAL in 20min
- Pulse intensity instability: $< 10\%$
- Pulse energy: 1 mJ/pulse at 440 nm, equivalent to 1.3 TeV in dynamic range

DC Kr Pumped Nd:YLF & Ti:S Lasers

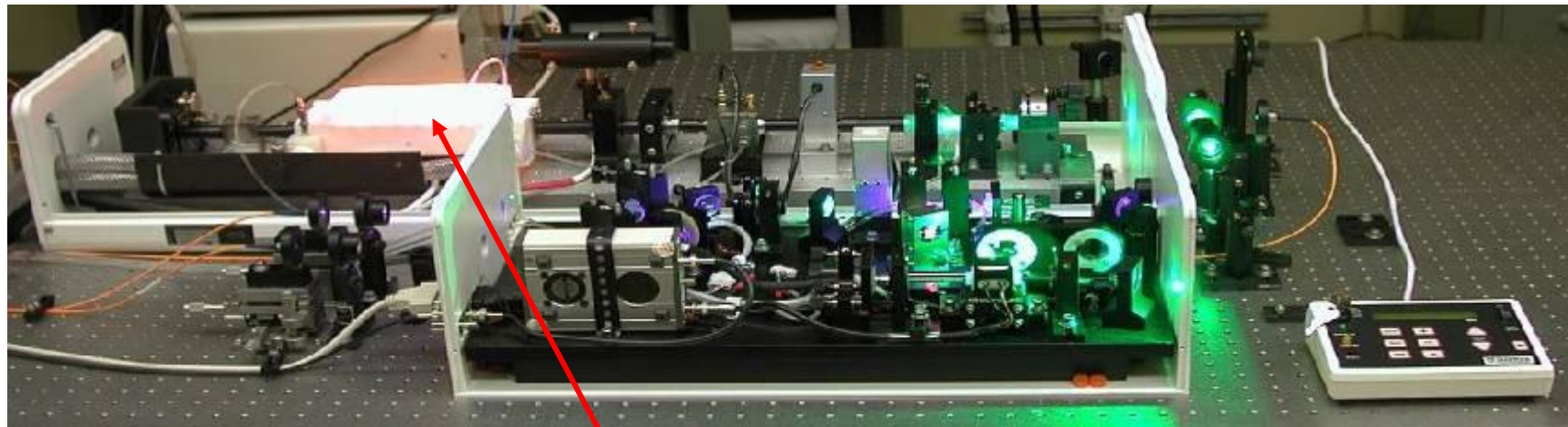

DC Kr lamp ages in time, so reduces laser pulse intensity, increases laser pulse width and timing.

Laser Light Distribution System

An optical fiber based two-level light distribution system designed and constructed by the Saclay group

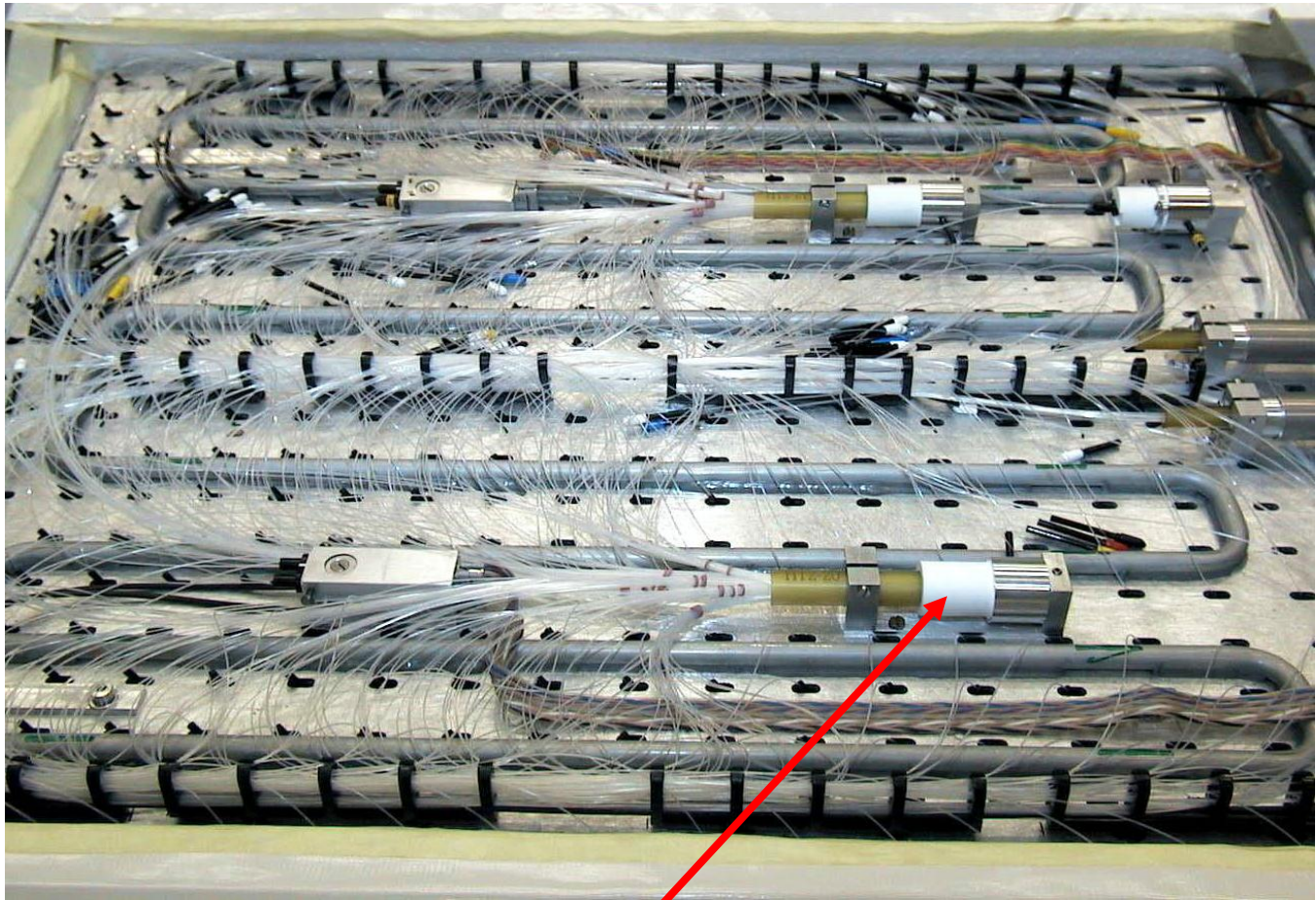

Fibers at front for barrel crystal

Fibers at back for endcap crystal

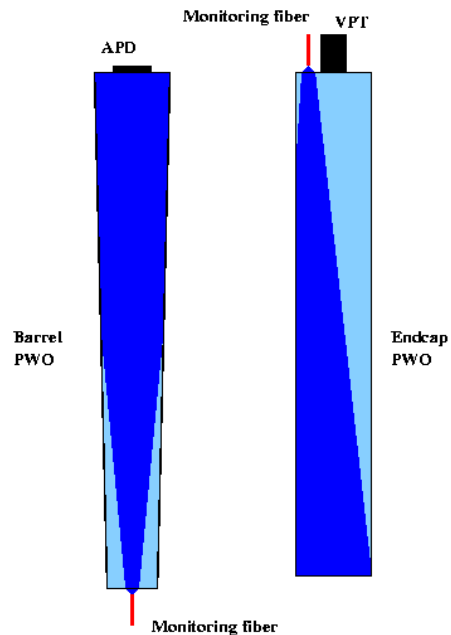

Integrating sphere based level-1 distribution for good uniformity

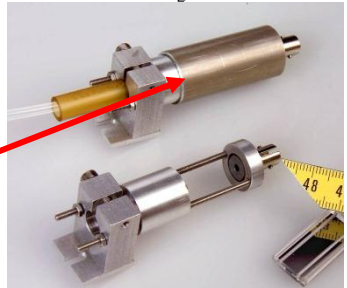

Laser DAQ and Distribution System

On-Line System

Off-Line System

- Digital scope
- Digital scope
- Camac and modules
- Safety box
- Diagnostic box
- Diagnostic box
- Monitoring box
- Monitoring box
- PC monitor
- 1 x 80 optical switch
- Attenuation box
- 2 x 1 optical switch
- PC
- Digital delay (DG535)
- Digital delay (DG535)
- Network
- GPIB - RS232
- GPIB - RS232

- Digital scope
- Camac and modules
- Diagnostic box
- PC monitor
- Network
- PC
- GPIB - RS232
- Digital delay (DG535)

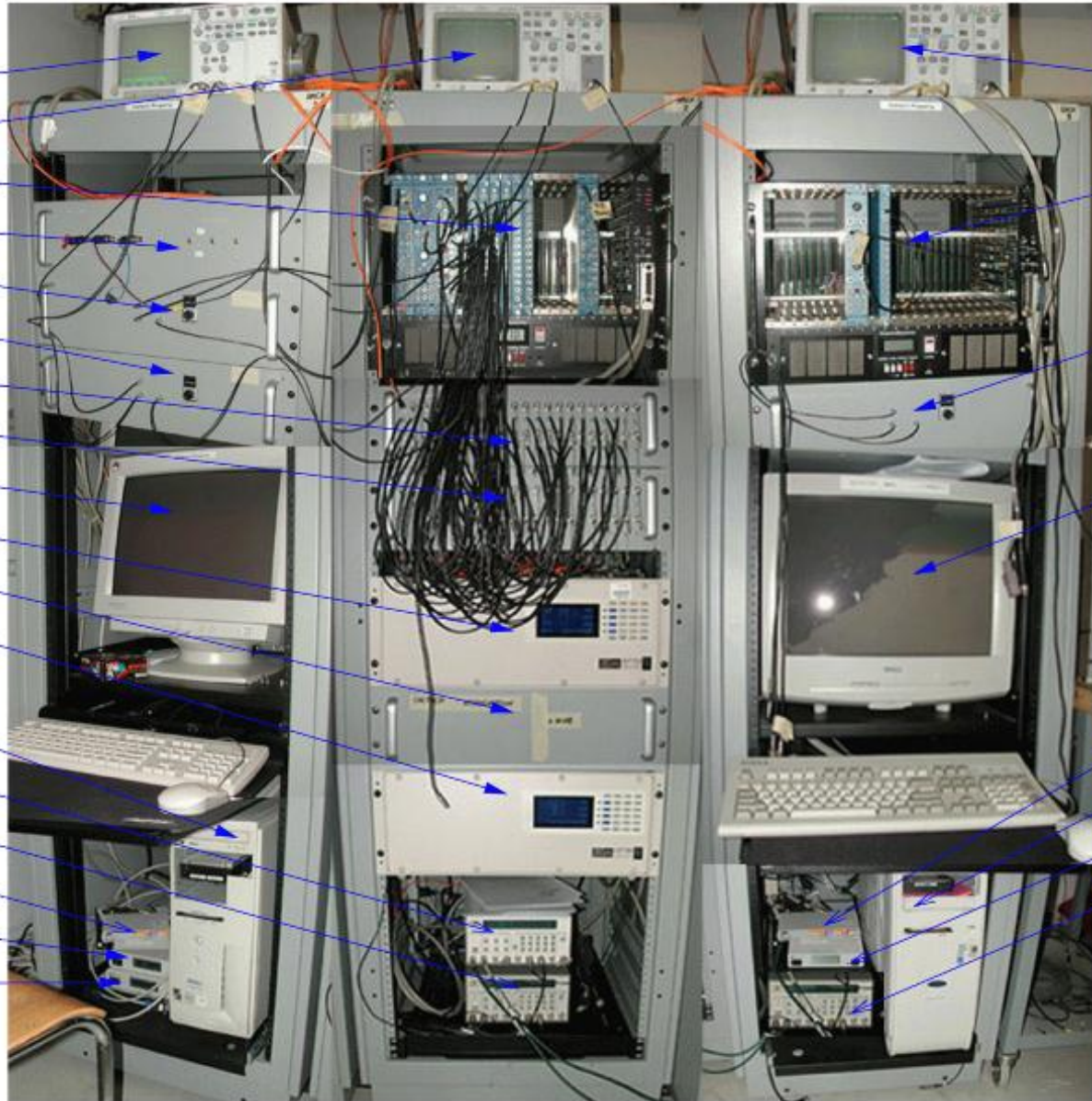

Software Feedback to Maintain Timing

Performance published in IEEE Trans. Nucl. Sci. vol. 52 pp. 1123-1130 (2005): 25 h stability of pulse energy & width: 3% and a long term degradation of laser pulse timing.

- Laser pulse intensity, width and timing are correlated to the YLF pumping current.
- Better pulse stability could be achieved by trimming the YLF laser pumping current.

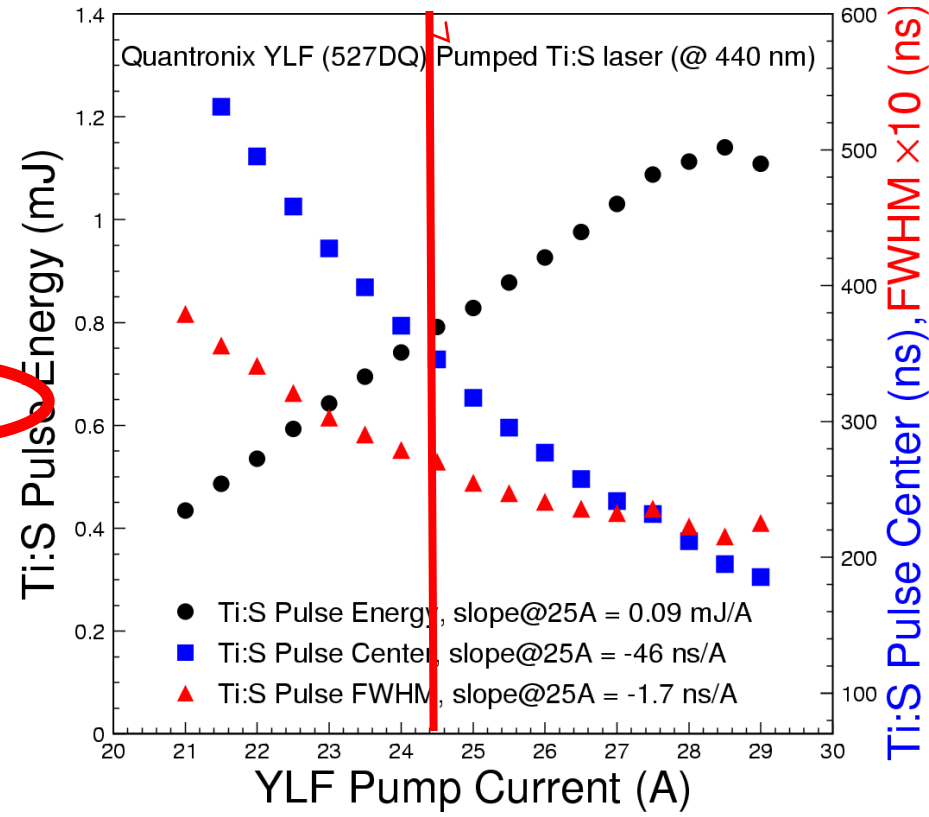
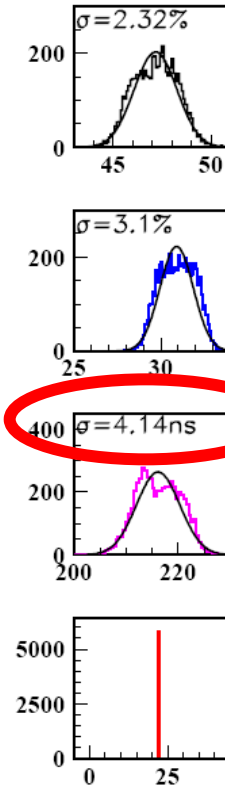
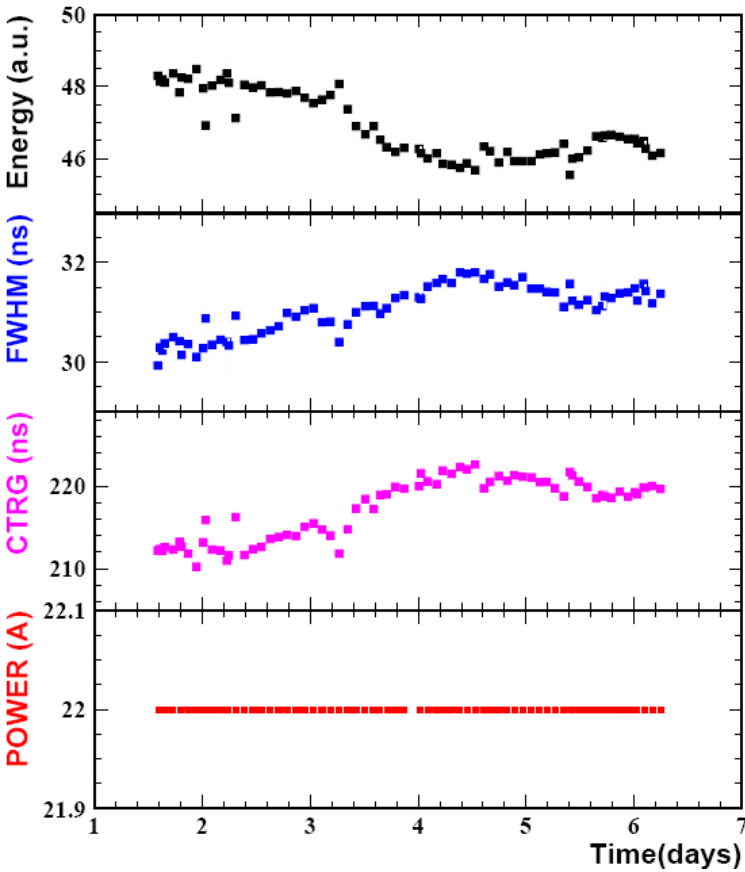

With a software feedback and an inserted delay the laser pulses show the same intensity and width with about 3% instability and 3 ns jitter.

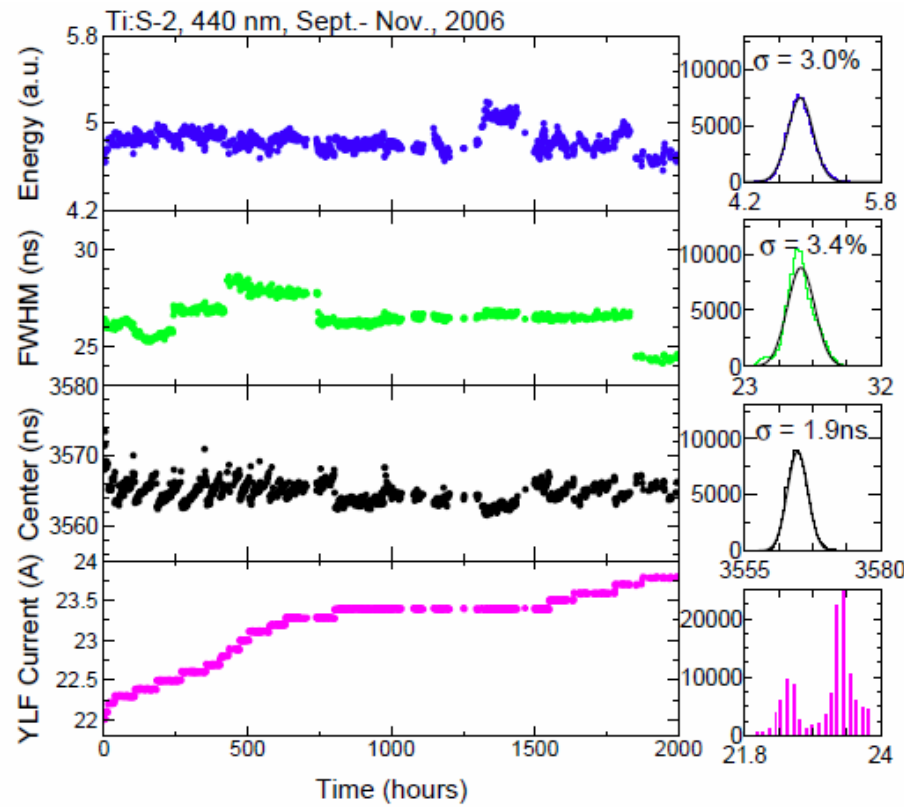
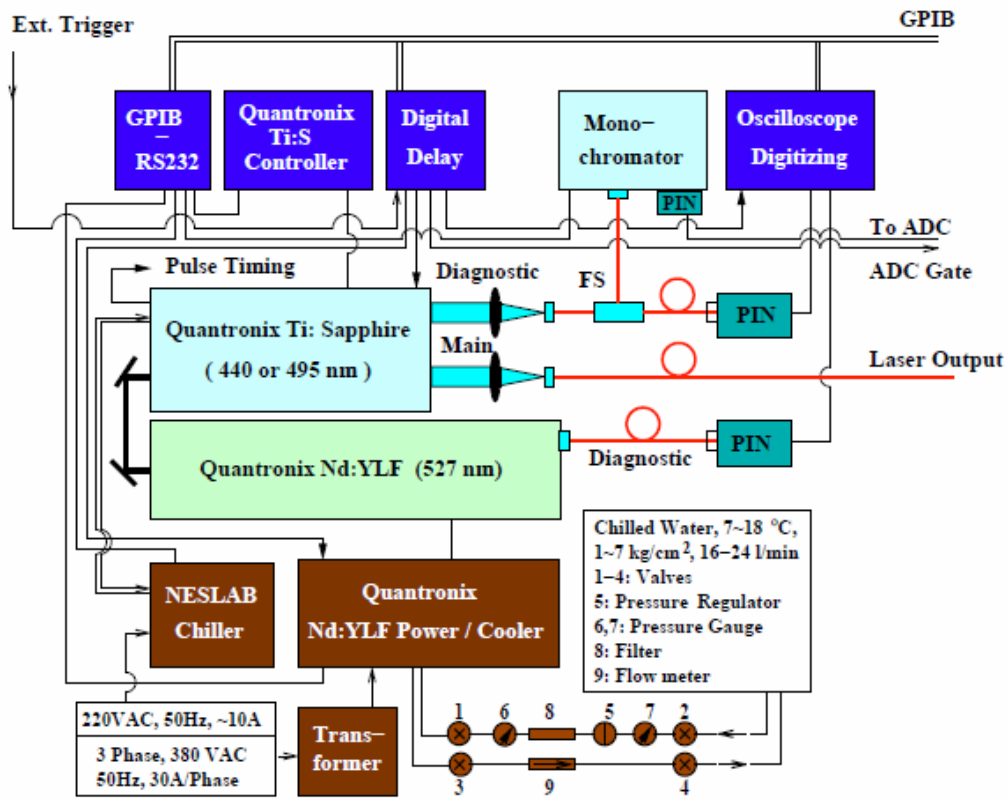

The system operates 24/7, providing 100% availability of the blue (440 nm) as well as the IR (800 nm) as the 2nd wavelength for the barrel.



ECAL Monitoring Stability



Julie Malcies, talk in CMS Weekly General Meeting, Nov 17, 2010

The blue laser data, taken between runs 132226 and 132914 for about 350 h in 2010, shows a mean stability of 0.05% for the barrel, and 0.06% for endcaps.

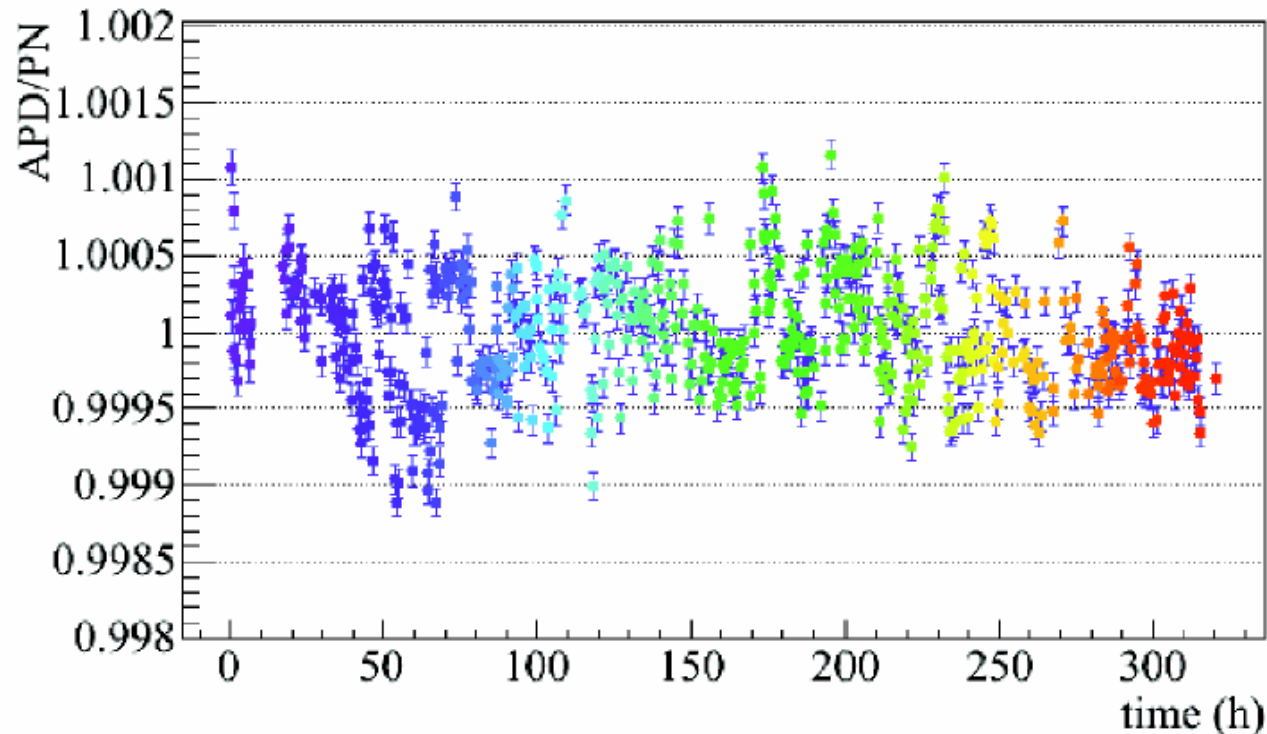
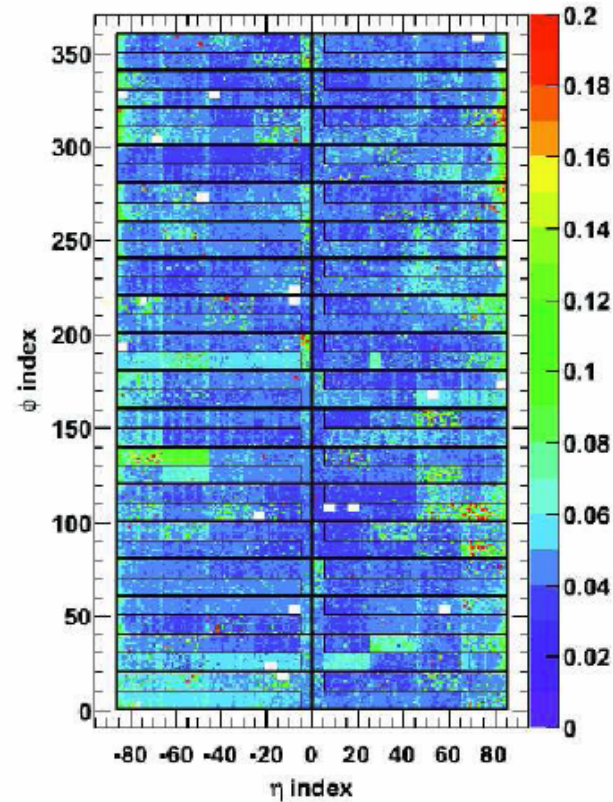



Four Existing Issues



1. No spares Dicon optical switches: 5 x 1 and 1 x 100. Current system will not function when they break.
2. Quantronix discontinued DC Kr lamp pumped Nd:YLF laser in 2005. Laser parts are no longer in production since 2009. The parts in Quantronix stock will last only for a limited time. Some parts, e.g. lamp power supply and pumping lamp housings etc., are no longer available.
3. Quantronix Ti:S lasers are custom made for CMS. They are more reliable than the Nd:YLF lasers with about 10% failing rate as compared to the YLF lasers. The scientist developed Ti:S lasers, however, left Quantronix. Long delays are experienced in obtaining replacement parts (LBO etc.) from Quantronix.
4. ECAL has not reached its designed resolution. APD/PN steps are observed but yet to be fully understood, some of which are laser intervention and swap related.



Laser Upgrade



The issue of Nd:YLF laser upgrade was raised to the ECAL management in 2008 with a formal proposal submitted in March, 2009, and presented in 2010 December ECAL General Meeting.

- New optical switches
- New solid state pump laser for Ti:Sapphire laser to replace Kr-lamp
- New orange laser for the EE to replace the LED system
- Spares for IR/orange lasers in EB and EE

Laser Committee Members: Brad Cox, Marc Dejardin, Roger Russack, Wolfram Zeuner, Ren-Yuan Zhu

Task – review modifications/upgrades of the laser system
Benefits, risks, integration, time schedule, costs
→ Recommendations



2010 Laser Run Experience



David Bailleux, Summary of Laser Runs

Current evolution show any laser interventions of adjustments:

- when it's get high something wrong;
- when restart from low current, working point, mean tuning;
- when current goes to decrease it's not so well, current should increased to compensate lamp aging. But this is theoretical because feedback is set on TIS timing now, not on the YLF energy

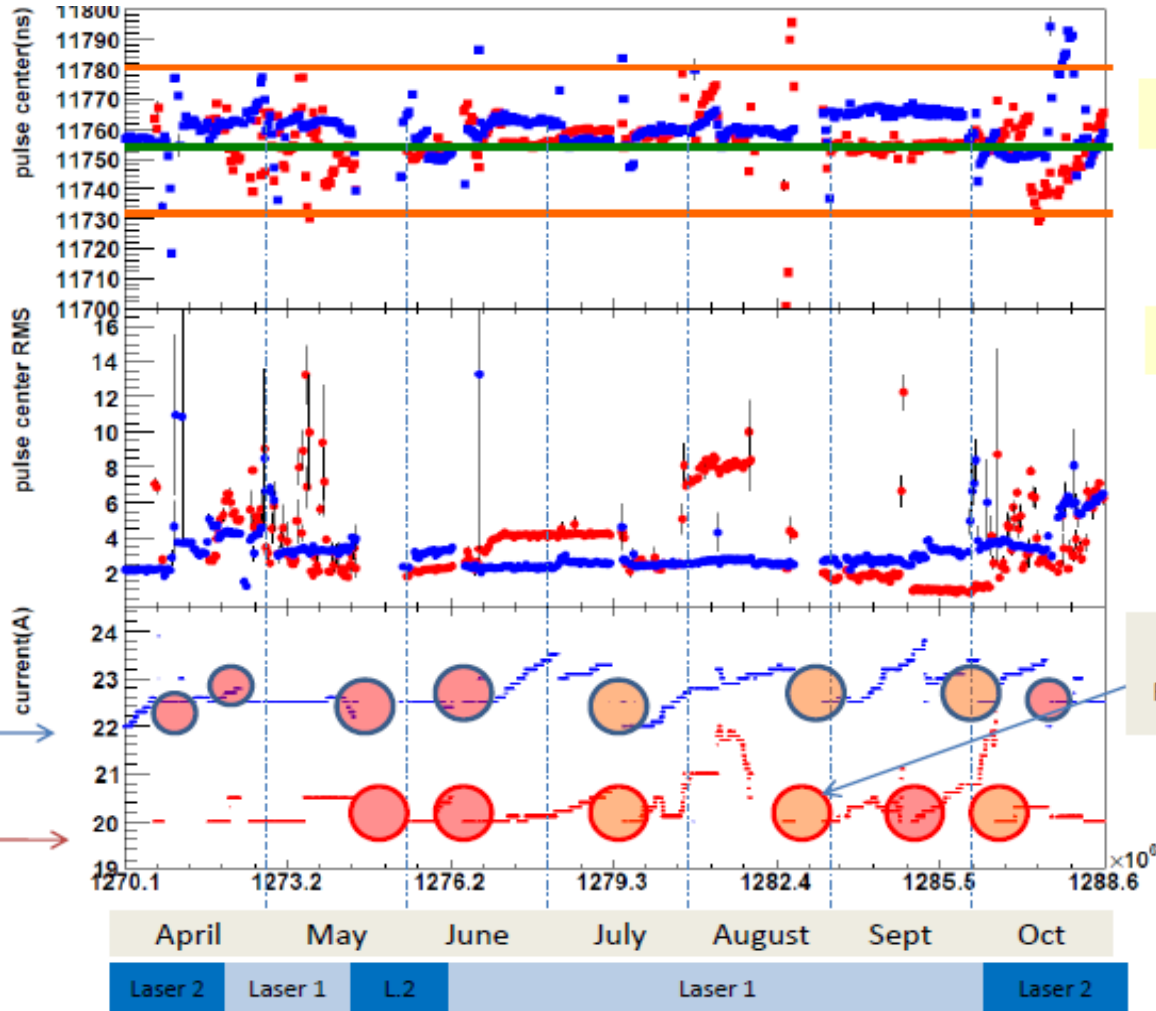

Blue laser intervention

Red laser intervention

Maintenance

Services

Long interruption RED laser: 1 week

With laser diode pump the lamp aging effect will be greatly reduced

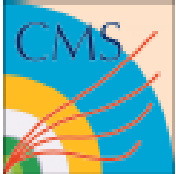

APD/PN Steps in 2010



Secs in 2010	Secs since 1/1/1970	Date	Comment from D.Bailleux	Other elog
5.50E+06	1.27E+09	3/5/10	Lasers restarted on 3rd March	Magnet ramped to 3.8T
6.36E+06	1.27E+09	3/15/10		EB/EE power cycled
7.30E+06	1.27E+09	3/26/10	Intervention on blue laser	
		4/11/10	blue laser became unstable; some tuning done	
		4/13/10	lasers swapped	
		4/14/10		Magnet ramped to 0T
9.05E+06	1.27E+09	4/15/10		Magnet ramped to 3.8T
		4/19/10	Tuning of blue laser	
		4/26/10		Magnet ramped to 0T
		4/27/10	Tuning of blue laser	
1.03E+07	1.27E+09	4/30/10	Tuning of blue on 27th April; started use on 30th April	Magnet ramped to 3.8T
		4/5/10	Quick tuning of blue laser	
1.07E+07	1.27E+09	5/5/10		
1.09E+07	1.27E+09	5/6/10		
1.11E+07	1.27E+09	5/9/10	Red laser problems ??	
		5/11/10	"Huge fluctuations" in run 135248; delay adjusted	
1.21E+07	1.27E+09	5/21/10	Water leak blue laser; lamp & tube broken; swapped lasers	
		5/28/10		Magnet ramped to 0T
		5/31/10	Laser maintenance	
		6/2/10		Magnet ramped to 3.8T
1.34E+07	1.28E+09	6/4/10	After magnet ramping	
1.40E+07	1.28E+09	6/11/10	Was low power for blue laser...	
		6/14/10	blue lasers swapped	
1.60E+07	1.28E+09	7/5/10		Laser became unstable....
1.72E+07	1.28E+09	7/18/10	laser maintenance	Magnet ramped to 0T
1.79E+07	1.28E+09	7/27/10		Magnet ramped to 3.8T
1.86E+07	1.28E+09	8/3/10		Magnet ramped to 0T and back to 3.8T
		8/16/10		Magnet ramped to 0T and back to 3.8T
2.00E+07	1.28E+09	8/20/10		First runs after magnet ramp
2.04E+07	1.28E+09	8/24/10	Red laser problems ??	Switch was stuck on blue laser etc.
		8/30/10	Maintenance of blue laser; flow tube cracked; misalignment	Magnet ramped to 0T
2.11E+07	1.28E+09	9/2/10	Gain 200 run - laser intensities were changed and reverted	Magnet ramped to 3.8T
2.14E+07	1.28E+09	9/5/10	Blue laser maintenance/tuning	
		9/23/10	Swapped blue lasers twice!	
2.39E+07	1.29E+09	10/4/10	Blue laser maintenance/tuning	
		10/19/10		Magnet ramped to 0T
2.56E+07	1.29E+09	10/23/10		Magnet ramped to 3.8T
2.59E+07	1.29E+09	10/27/10		Magnet ramped to 2T and back to 3.8T
2.64E+07	1.29E+09	11/2/10	Increased blue laser power	Magnet ramped to 2T and back to 3.8T
2.71E+07	1.29E+09	11/10/10	Swapped blue lasers	
		11/17/10		Magnet ramped to 2T and back to 3.8T
2.78E+07	1.29E+09	11/18/10	Swapped blue lasers	
2.80E+07	1.29E+09	11/20/10	Blue laser delay adjusted (was off by 25ns)	

LAMP or flow tube
BROKEN BLUE LASER

- 14 April
- 21 May
- 14 June
- 31 august

Others are usual
maintenance

Among 26 steps: 10 B on/off, 9 Laser interventions, 4 ECAL power on/off, 3 unknown



Possible Origin of APD/PN Steps



B field on/off: May affect both lasers and MEM readout. Existing Mu material shielding is not 100% effective. Moving lasers out of the B field would eliminate the uncertainty caused by lasers, but with a cost consequence (new barracks at the ground).

Laser maintenance and swap: Pre-pulse may be caused by leakage of the pumping pulse at 527 nm. Green blocking filters were installed for both lasers. The one on laser 2 was found broken and fixed in June, 2011. It is interesting to see if steps persist after June service when filters were fixed. In any case, this effect should be greatly reduced, if not eliminated, by using DPSS laser with long MTBF.

Laser pulse shape (FWHM, timing and intensity) corrections: Considering possible laser pulse dispersion in the fiber distribution system a better set of corrections extracted *in situ* should help.

ECAL on/off: Nothing can be done unless changing readout electronics.



Laser Interventions in 2011



Dates	Lasers	services	maintenances
8 Feb	Laser3	Lamp flow tube broken	
9 Feb	Laser3	TiS : new HV pulser	
1 March	Laser1		lamp
2 March	Laser3 Laser2	Lamp broken Leak YLF	
3 May	Laser2	Lamp flow tube broken	
5 May	Laser3		lamp
Mid May	Laser3	Valve – cooling issue YLF	
1 June	Laser2-Laser3	Logic unit – power supply start trouble on laser2	
7 June	Laser1	New HV + new Q-switch	lamp
20 June	Laser3	Lamp flow tube broken	
4-6 July	Laser3	Transformer 207V New crystal	lamp
19 July	Laser1		lamp
22 July	Laser1-2	Neslab issue	
30 August	Laser1 Laser3		lamp

Laser 2 Ti:S services from Mid-May not included. No lamp braking related to B field for the blue



Laser Committee Recommendations



W. Zeuner, 6/28/11, ECAL Meeting

- The system must be kept running in today's configuration until LS1 (this might be as long as until spring 2013 !)
Therefore enough spares must be procured now
- A second large optical switch must be procured a.s.a.p.
- In view of the long term operation, it is not sufficient to replace only the pumping laser of the blue laser system.
- The entire blue laser system must be replaced.
It can be expected that the new system will show much less jumps in the APD/PN ratio
A market survey should be performed before purchasing
One laser should be procured in FY12 to perform tests of long term stability
The general parameters (wavelength, pulse length, shape and stability, jitter.... can be used from the current system
The energy of the current laser is an advantage, but not absolutely mandatory depending on the chosen technology it might come as by product of the required stability.
- There is no need for yet another frequency laser (green)



Revised Specifications for RFQ



- **Pulse FWHM: < 30 ns to match ECAL readout**
- Pulse jitter: < 3 ns for synchronization with LHC
- **Pulse rate: 0-100 Hz, scan of full ECAL in 20min**
- **Pulse intensity instability: $< 3\%$**
- Pulse energy: 1 mJ/pulse at 440 nm, equivalent to 1.3 TeV in dynamic range
- **Pulse delay from external trigger: < 90 μ s, for monitoring trigger to stay in one LHC beam cycle**

The laser will be integrated into the existing monitoring system, so a compact system is highly desired. The laser will be run in the 24/7 mode, the MTBR (mean time between repairs) is required to be better than 3 months.



Issues Still Under Discussion



The laser pulse intensity in use is 40 (barrel) and 200 μJ (endcaps). An additional factor of two intensity is needed if lasers are moved to the ground.

The stability of laser pulse intensity may be relaxed to 10% according to Marc. DPSS lasers in DC mode satisfy 3%.

The laser pulse width: Less than 1 ns is possible, but need mode-lock technology which is expansive with large jitter. Below 10 ns is also possible using Ti:S technology, but requires lasers diode be pulsed powered (instead of DC), which causes a long trigger delay and poor pulse intensity stability. Less than 25 ns is achievable with DPSS in DC + Nd:YLF + Ti:S technology.

More precise measurement of FWHM by 2 Ghz digitizer instead of 1 Ghz, may help. Laser pulse dispersion in the fiber distribution system, however, should also be taken into the consideration.

36 1 x 2 fiber splitters may be used, leading to 36 channels (instead of 72) for the barrel to be scanned. If so, the required laser pulse intensity between the barrel and endcaps would be equalized, the total scan time is reduced from 20 minutes to < 12 minutes and no additional switch procurement is needed.



12 Manufactures Contacted



1. Photonics Industries International, Inc, 390 Central Ave., Bohemia, NY 11716
2. Continuum Sub. of GSI Group, 3150 Central Expy., Santa Clara, CA 95051
3. Quantronix, 41 Research Way, East Setauket, New York 11733
4. CrystaLaser LC, 4750 Longley Lane, Reno, NV 89502
5. Spectra-Physics Lasers, A Newport Corp. Brand, 3635 Peterson Way, Santa Clara, CA 95054
6. New Focus, A Newport Corp. Brand, 3635 Peterson Way, Santa Clara, CA 95054
7. JDSU, 430 N McCarthy Blvd., Milpitas, CA 95035
8. Coherent Inc., 5100 Patrick Henry Dr., Santa Clara, CA 95054
9. Teem Photonics USA, Sub. of Teem Photonics SA, 3594 Nyland Way, Ste. TP1, Lafayette, CO 80026
10. IPG Photonics Corporation, 50 Old Webster Rd., Oxford, MA 01540
11. Laserglow Technologies, 216-5 Adrian Ave., Toronto, ON M6N 5G4, Canada
12. Quantel USA, 601 Haggerty Lane, PO Box 8100, Bozeman, MT 59715-2001



Outcome of RFQ



Four quotations were received.

The CrystaLaser quotation provides a laser with low cost. Its low intensity ($10 \mu\text{J}$ instead of 1 mJ), however, falls short for CMS ECAL monitoring.

The Quantronix quotation is at high cost. The company went to fs/ps laser market.

Two quotations are received from Photonics for laser pulse intensity of 0.4 and 1 mJ . Since the cost difference is very small ($\$10\text{k}$) 1 mJ option is preferred. Discussions with Photonics on technical details, such as long term reliability, maintenance and service requirements, spare parts and safety etc., are on-going.



440 nm Options: 1 & 0.4 mJ



Quotation Number: Q10-1202AI2
Date: 12/1/10
Valid Until: 1/10/10
Payment: 25/50/25 (Pending credit approval)
Freight: F.O.B. Bohemia, NY
Delivery: 12-16 Weeks ARO – (exact delivery schedule at time of order acceptance)

Quotation

Quotation Number: Q10-1201AI2
Date: 12/1/10
Valid Until: 1/10/10
Payment: 25/50/25 (Pending credit approval)
Freight: F.O.B. Bohemia, NY
Delivery: 12-16 Weeks ARO – (exact delivery schedule at time of order acceptance)

Quotation

To:	California Institute of Technology 1200 E California Blvd, Pasadena CA 91125	From:	Photonic Industries 390 Central Avenue Bohemia, NY 11716
Tel:		Tel:	631-218-2240
Fax:		Fax:	631-218-2275
Attn:	Liyuan Zhang	Attn:	Andrew Iadevaia
Description		Unit Price	Qty
TU-L Ti: Sapphire Laser		\$190,000.00	1
Wavelength	440nm		
Pulse Energy @ 100Hz	1mJ		
Pulse Width @ 100Hz	<25 ns		
Beam Mode	TEM ₀₀		
Pulse Jitter	<3ns rms		
Divergence	<2mRad		
Pulse to Pulse Instability	3%/rms		
Pulse delay from external trigger	< 5 μs		
Pulse Repetition Rate	0 to 100Hz		
DM-527-30 Pump Laser System for above TU-L Ti: Sapphire Laser			
Q-switched DPSS Nd: YLF			
DM Power Supply Unit	INCLUDED	1	INCLUDED
Available in 110VAC or 220VAC formats, 50-60Hz, single phase power. Standard RS232 control interface, Q-switch internal input via RS232 and external input by TTL via BNC. Dimensions: 483mm (19.0") W x 476mm (18.75") D x 178mm (5.25") H.			
Standard DM Cooling Unit	INCLUDED	1	INCLUDED
110VAC or 220VAC units available, 50-60Hz, single phase power. Dimensions: 320.5mm (12.62") W x 606mm (23.87") L x 511mm (20.12") H.			
System Software	INCLUDED	1	INCLUDED
DM Control software provides basic system operating controls in a convenient graphical user interface configuration.			
Warranty	INCLUDED	1	INCLUDED
Standard Photonic Industries one-year parts and labor warranty.			

To:	California Institute of Technology 1200 E California Blvd, Pasadena CA 91125	From:	Photonic Industries 390 Central Avenue Bohemia, NY 11716
Tel:		Tel:	631-218-2240
Fax:		Fax:	631-218-2275
Attn:	Liyuan Zhang	Attn:	Andrew Iadevaia
Description		Unit Price	Qty
TU-L Ti: Sapphire Laser		\$180,000.00	1
Wavelength	440nm		
Pulse Energy @ 100Hz	0.4mJ		
Pulse Width @ 100Hz	<25 ns		
Beam Mode	TEM ₀₀		
Pulse Jitter	<3ns rms		
Divergence	<2mRad		
Pulse to Pulse Instability	3%/rms		
Pulse delay from external trigger	< 5 μs		
Pulse Repetition Rate	0 to 100Hz		
DM-527-30 Pump Laser System for above TU-L Ti:Sapphire Laser			
Q-switched DPSS Nd: YLF			
DM Power Supply Unit	INCLUDED	1	INCLUDED
Available in 110VAC or 220VAC formats, 50-60Hz, single phase power. Standard RS232 control interface, Q-switch internal input via RS232 and external input by TTL via BNC. Dimensions: 483mm (19.0") W x 476mm (18.75") D x 178mm (5.25") H.			
Standard DM Cooling Unit	INCLUDED	1	INCLUDED
110VAC or 220VAC units available, 50-60Hz, single phase power. Dimensions: 320.5mm (12.62") W x 606mm (23.87") L x 511mm (20.12") H.			
System Software	INCLUDED	1	INCLUDED
DM Control software provides basic system operating controls in a convenient graphical user interface configuration.			
Warranty	INCLUDED	1	INCLUDED
Standard Photonic Industries one-year parts and labor warranty.			



440 nm Options: < 10 ns FWHM



Photronics Industries

390 Central Ave., Bohemia, NY 11716, USA
Tel: 631-218-2240 Fax: 631-218-2275
www.photonix.com info@photonix.com

Quotation

Quotation Number: Q11-0928AI
Date: 9/21/11
Valid Until: 10/21/11
Payment: 25/50/25 (Pending credit approval)
Freight: F.O.B. Bohemia, NY
Delivery: 12-16 Weeks ARO – (exact delivery schedule at time of order acceptance)

To:	California Institute of Technology 1200 E California Blvd, Pasadena CA 91125	From:	Photronics Industries 390 Central Avenue Bohemia, NY 11716	
Tel:		Tel:	631-218-2240	
Fax:		Fax:	631-218-2275	
Attn:	Liyuan Zhang	Attn:	Andrew Iadevaia	
	Description	Unit Price	Qty	Total
	Laser	\$250,000.00	1	\$250,000.00
	Wavelength	440nm		
	Pulse Energy @ 100Hz	0.3mJ		
	Pulse Width @ 100Hz	<10 ns		
	Beam Mode	TEM ₀₀		
	Pulse Jitter	<3ns rms		
	Pulse delay from external trigger	<90usec		
	Divergence	<2mRad		
	Pulse to Pulse Instability	5%rms		
	Pulse Repetition Rate	0 to 100Hz		
	Power Supply Unit	INCLUDED	1	INCLUDED
	Available in 110VAC or 220VAC formats, 50-60Hz, single phase power. Standard RS232 control interface, Q-switch internal input via RS232 and external input by TTL via BNC. Dimensions: 483mm (19.0") m x 476mm (18.75") D x 178mm (5.25") H.			
	Standard Cooling Unit	INCLUDED	1	INCLUDED
	110VAC or 220VAC units available, 50-60Hz, single phase power. Dimensions: 320.5mm (12.62") W x 606mm (23.87") L x 511mm (20.12") H.			
	System Software	INCLUDED	1	INCLUDED
	Control software provides basic system operating controls in a convenient graphical user interface configuration.			
	Warranty	INCLUDED	1	INCLUDED
	Standard Photronics Industries one-year parts and labor warranty. Warranty repairs are to be performed at Photronics Industries factory or at customer's site where travel & living expenses are paid by customer			

Consequence
Low intensity: 0.3 mJ
Long delay: < 90 μs
Poor stability: 5%
High cost: \$250k



DPSS Laser Reliability

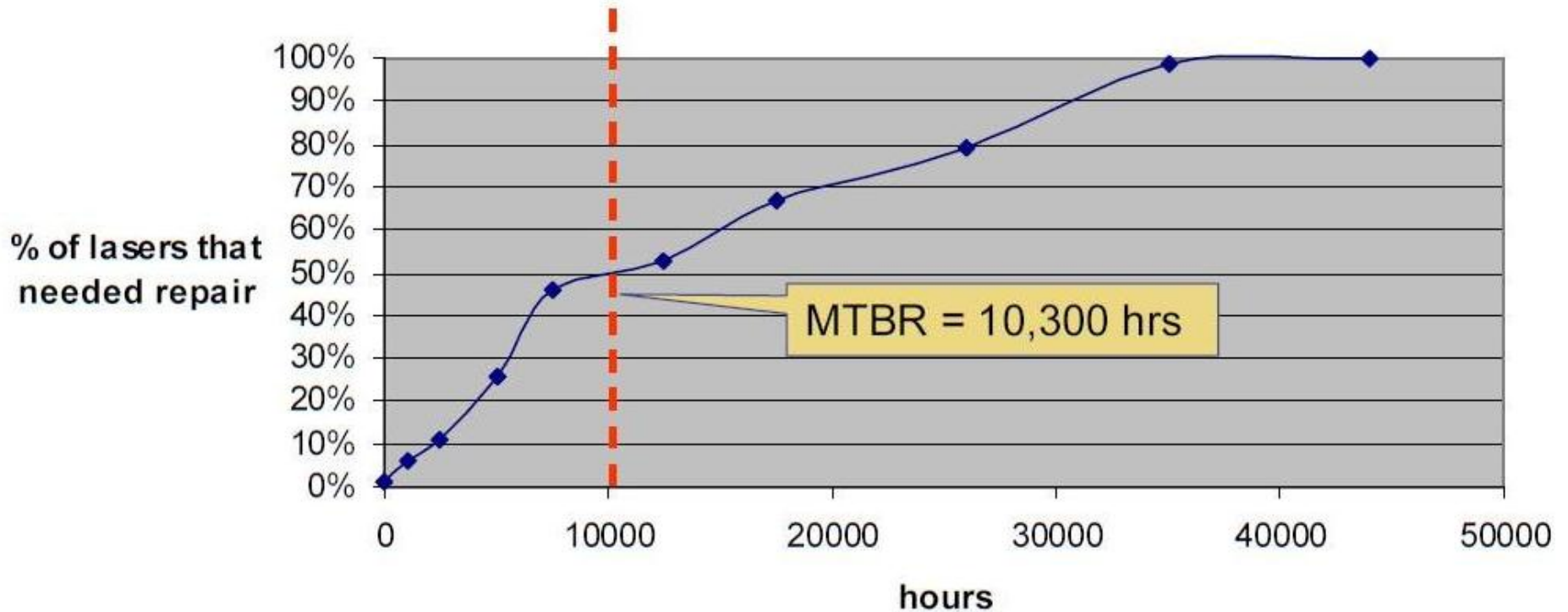

Unlike lamp pumped lasers, this laser does not need extensive maintenance service.



User References



Photonics Industries claims that most of its diode pumped lasers are used in military and private industry.

Oakridge National Lab

Dr. Yuan LIU commented on a diode pumped Nd:YLF pumped Ti:Sapphire laser system of Photonics Industries procured about one and half year ago. The laser system is run at 10 KHz in 24/7 mode for several weeks each run. While the Ti:Sapphire laser has no problem, the Nd:YLF had a problem caused by condensed water and it was fixed by Photonics Industries. She recommended Photonics Industries.

University of Washington (Prof. Thomas SPIRO group)

Dr. Balakrishnan commented on their Nd:YLF pumped OPO system of Photonics Industries purchased about 5 yrs ago. They are basically satisfied with the laser. The laser is run at 1 KHz, but NOT in 24/7 mode. The original diode module is still in good shape with accumulated time of over 3,500 hrs. There were some small issues like power dropping, chiller not working properly etc. The service is not as good as expected. While hoping Photonics will improve its service, they recommended the Photonics Industries.



Adding a New Blue Laser



Caltech Dec 14, 2007

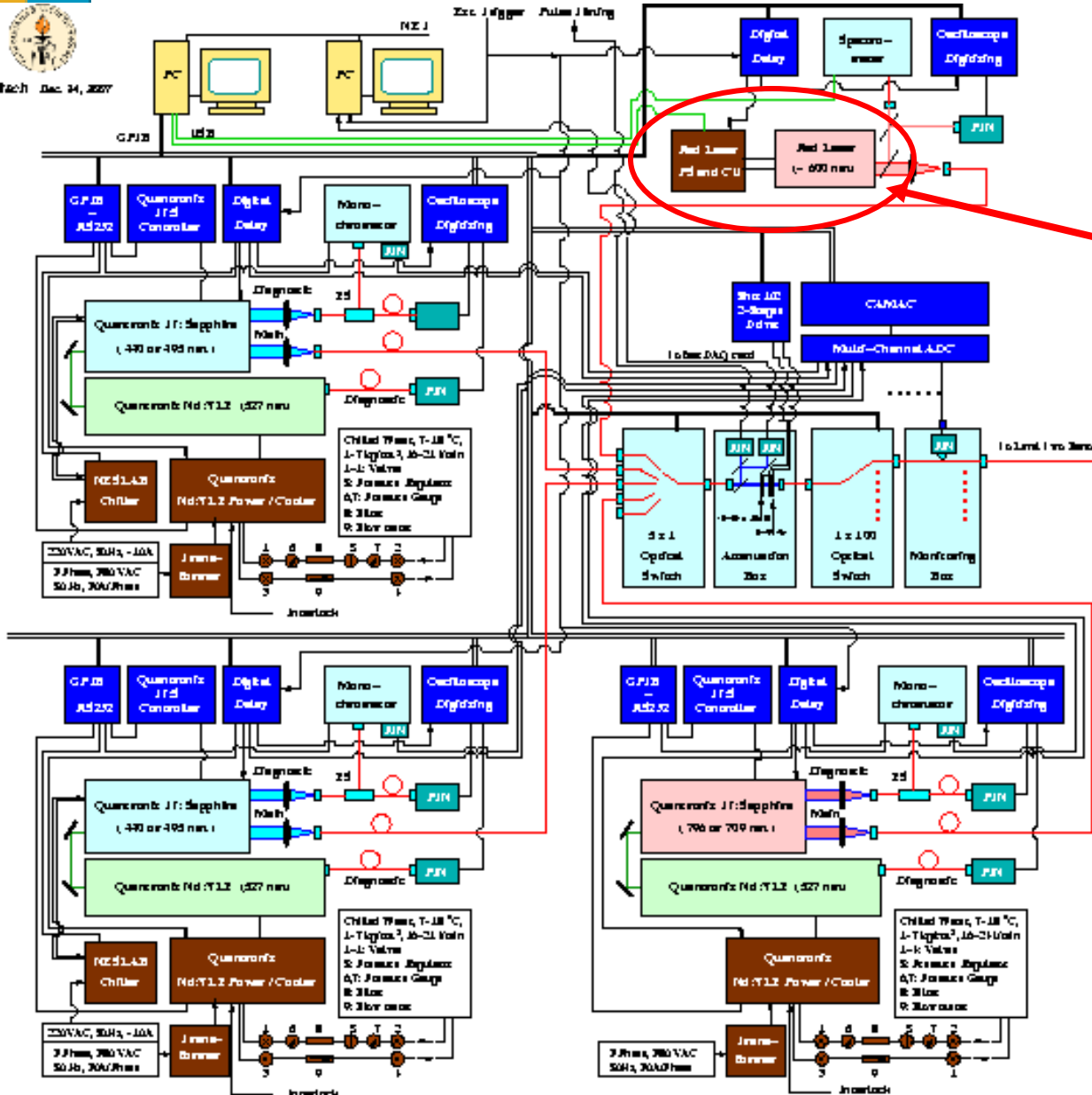

With the existing 5 x 1 switch a new blue laser at 440 nm may be added into the existing system.

Laser Hardware Needed

- 1) Laser & Power Supply and Cooler Unit;
- 2) Optics for fiber coupling;
- 3) Diagnostics: DSO and Spectrometer;
- 4) Trigger Electronics: Digital Delay.

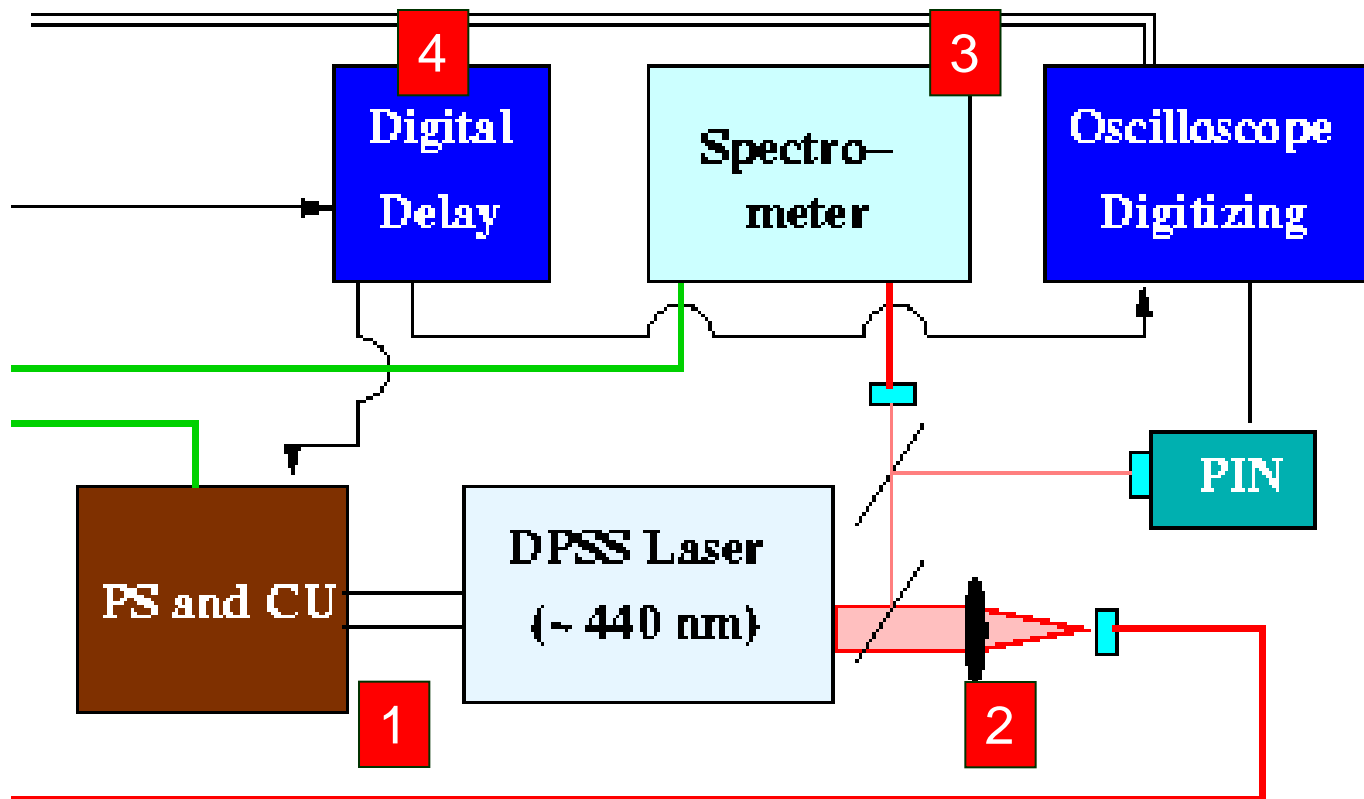



Summary: Proposed Actions



Laser system plays a crucial role in providing a precision PWO calorimeter *in situ*. The existing laser system performs as designed. The current system, however, is going to be unmaintainable soon. The proposed upgrade to DPSS lasers would also improve overall performance.

1. Procure two Dicon switches: 5 x 1 and 1 x 100, or insert thirty six 1 x 2 splitters and modify Laser Supervisor.
2. Procure a DM-527-30 Q-switched DPSS Nd:YLF laser pumped 1 mJ TU-L Ti:Sapphire laser at 440 nm from Photonics Industries, Inc.
3. This procurement went through CMS MB and FB in August. The time needed from issuing a PO to laser commission at P5 is expected to be 28 weeks with a schedule contingency. The goal is to use this system for 2012 runs.