



---

# 1<sup>st</sup> Report on Twenty Mu2e BaF<sub>2</sub> Crystals from SIC

**Ren-Yuan Zhu**

California Institute of Technology

June 25, 2014

# Crystal Samples and Experiment



Sample ID	Received Date	Dimension (mm <sup>3</sup> )	Total #	Polish
SIC-1,20	4/25/2014	30× 30 × 250	20	Six surfaces

Properties measured: longitudinal transmittance, FWHM resolution for 511 keV  $\gamma$ -rays, decay kinetics and light response uniformity.

# Longitudinal Transmittance of No 1-10

Good transmittance approaching theoretical limit

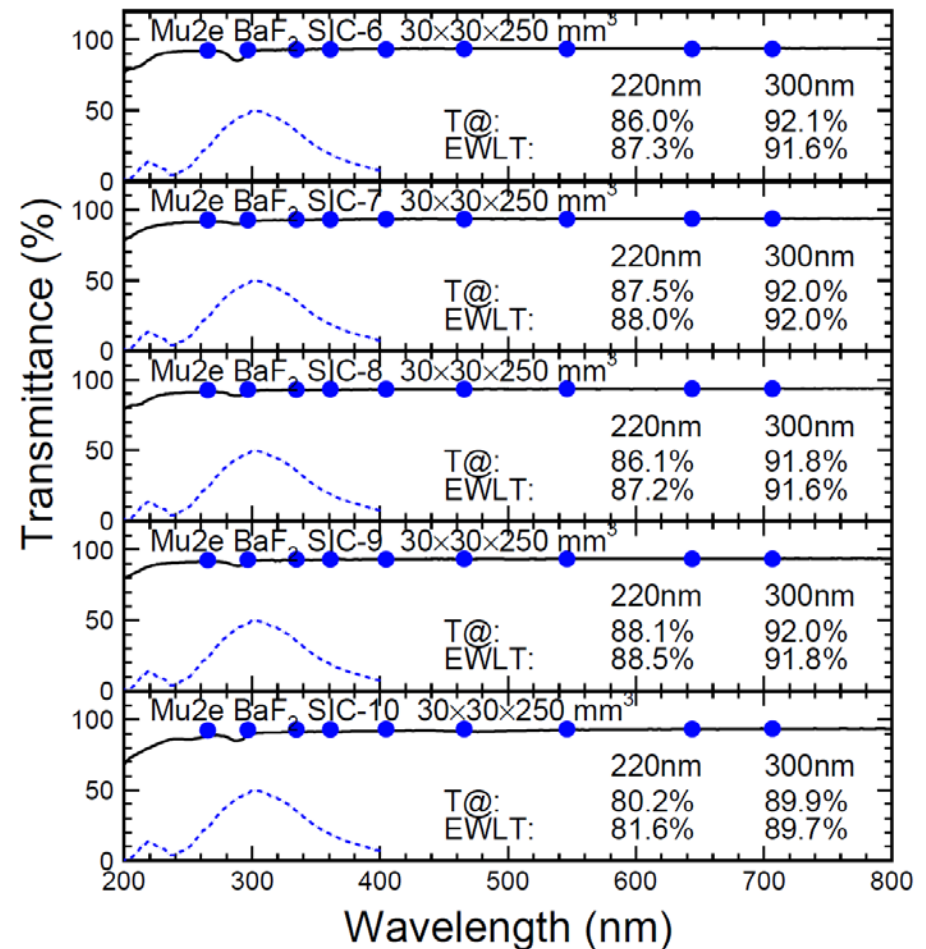
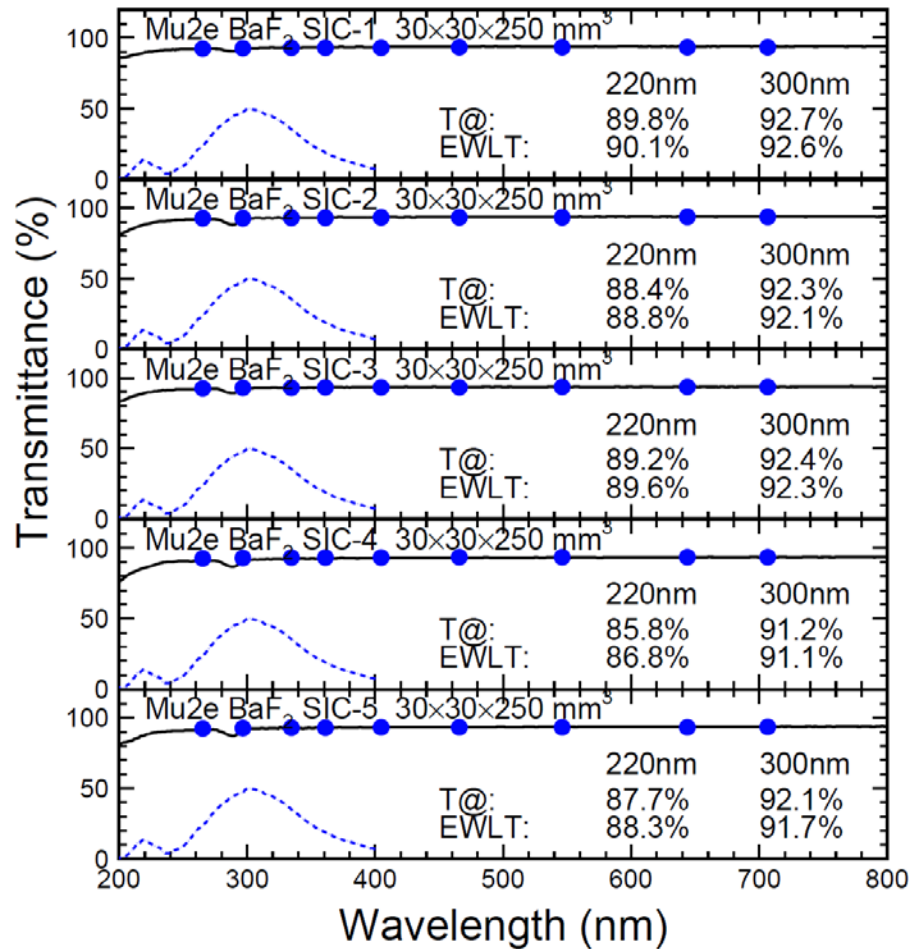

# Longitudinal Transmittance of No 11-20

Good transmittance approaching theoretical limit

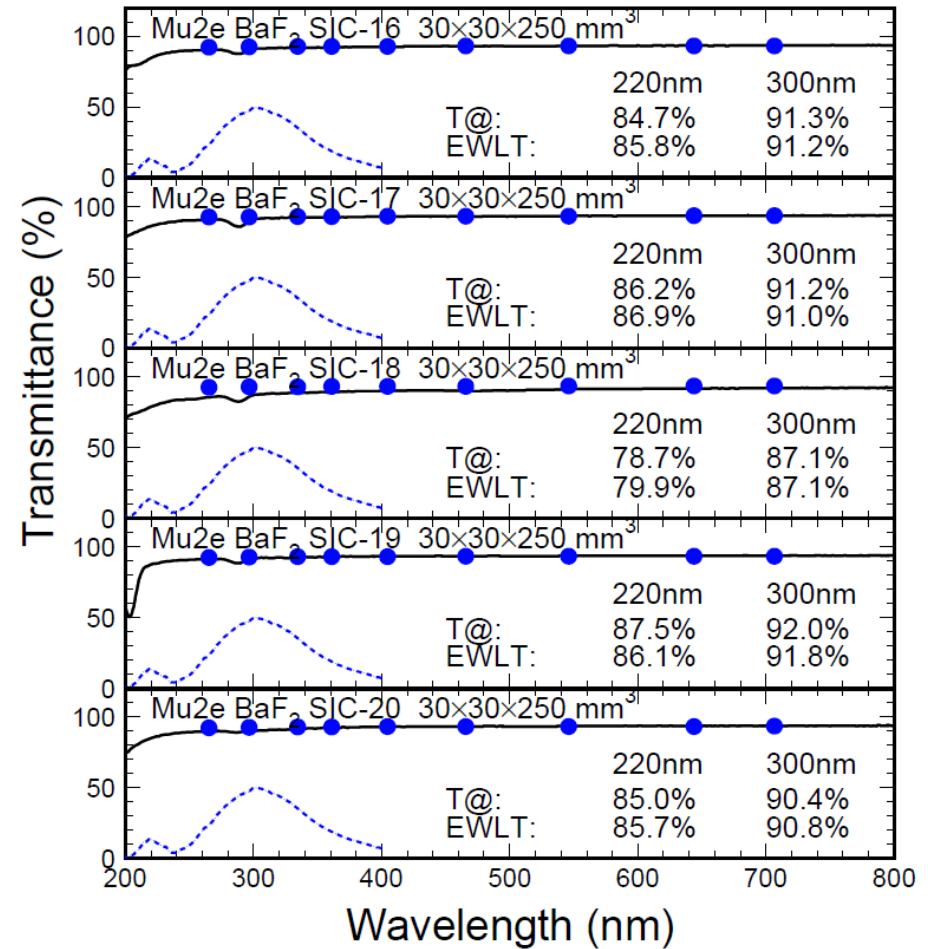
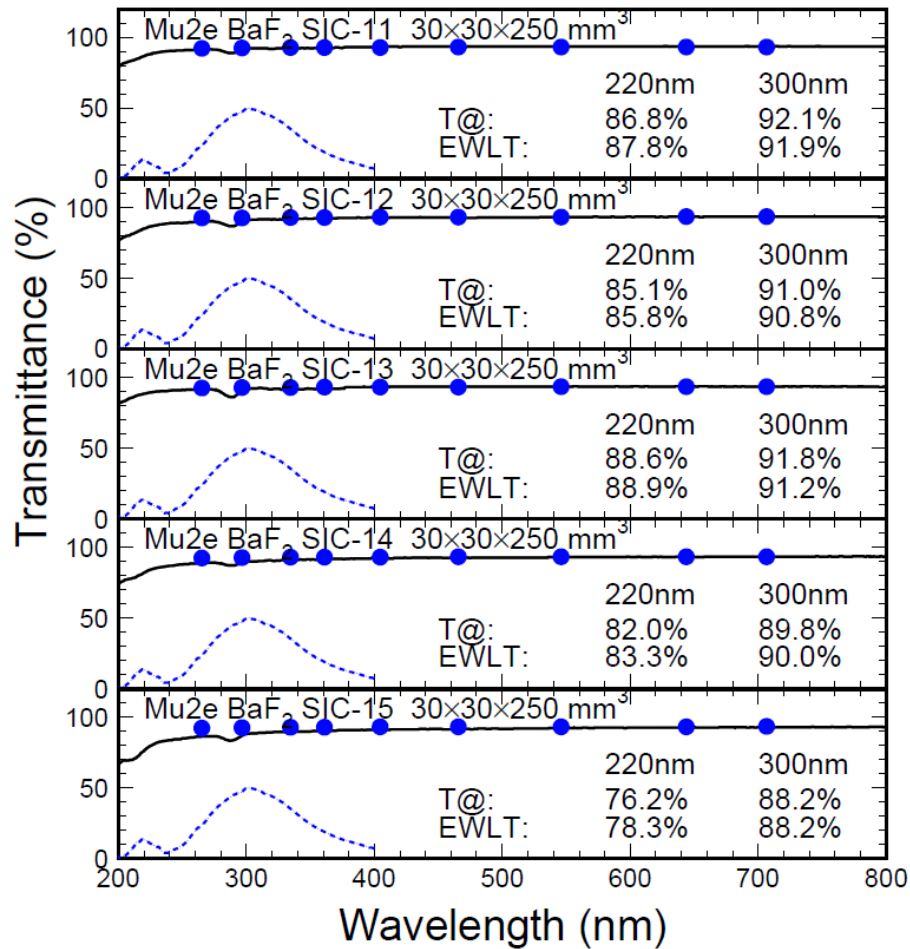

# Summary of LT

Consistency of 4.1% and 1.6% respectively at 220 nm and 300 nm

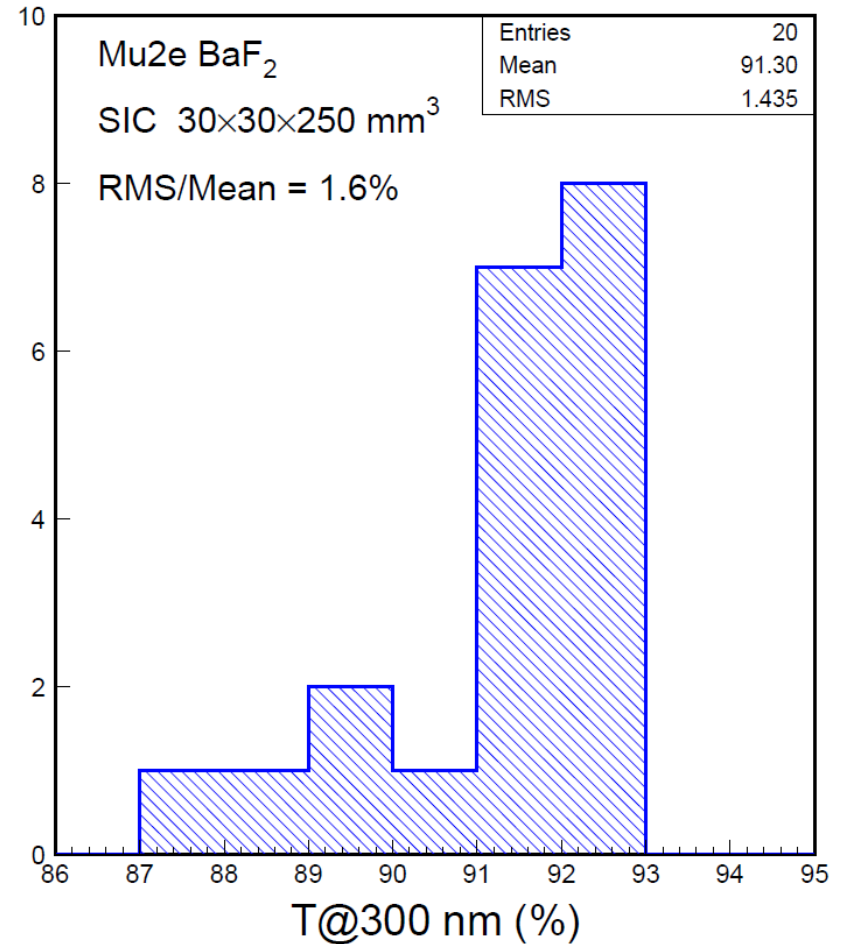
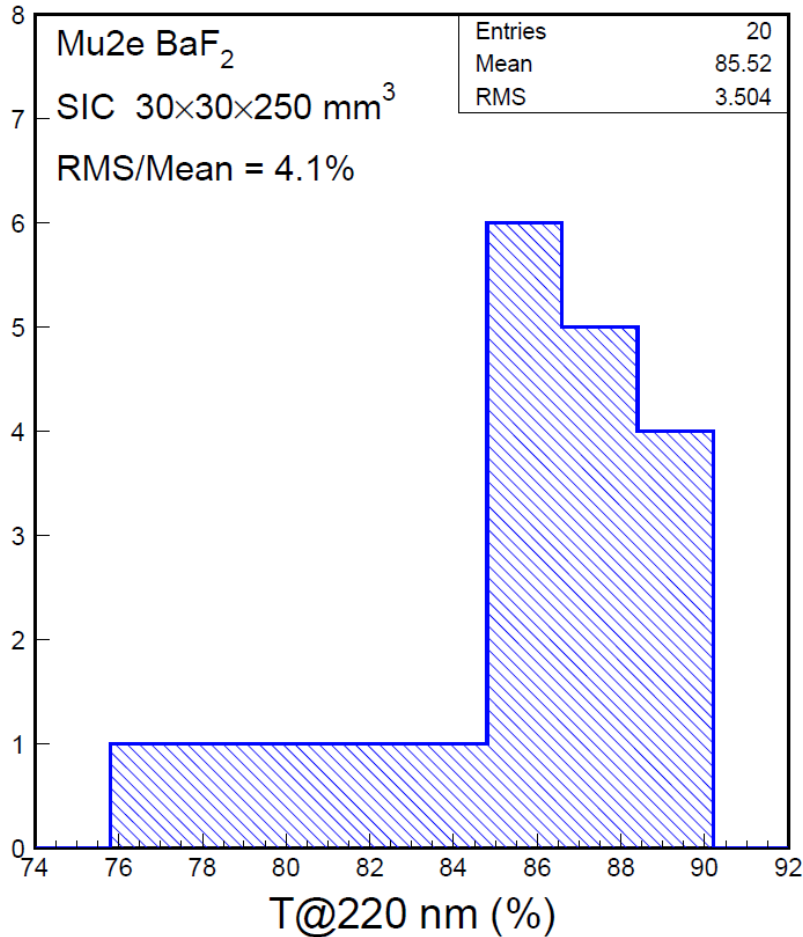

# Summary of EWLT

Consistency of 3.6% and 1.4% respectively for fast and slow component

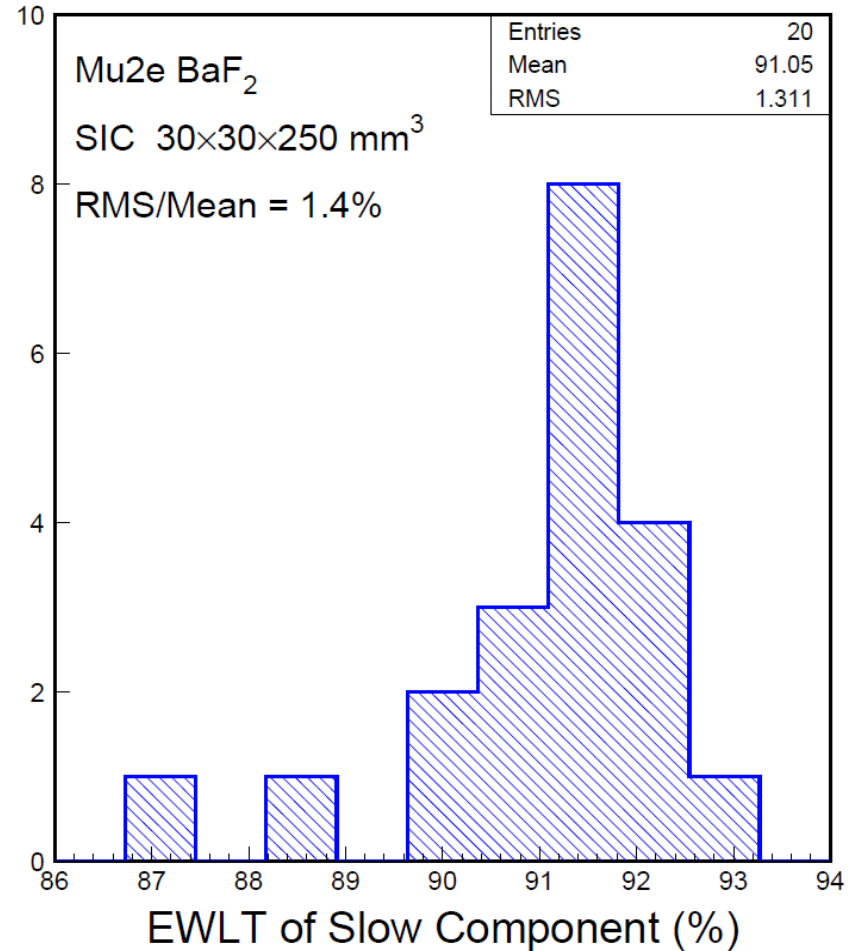
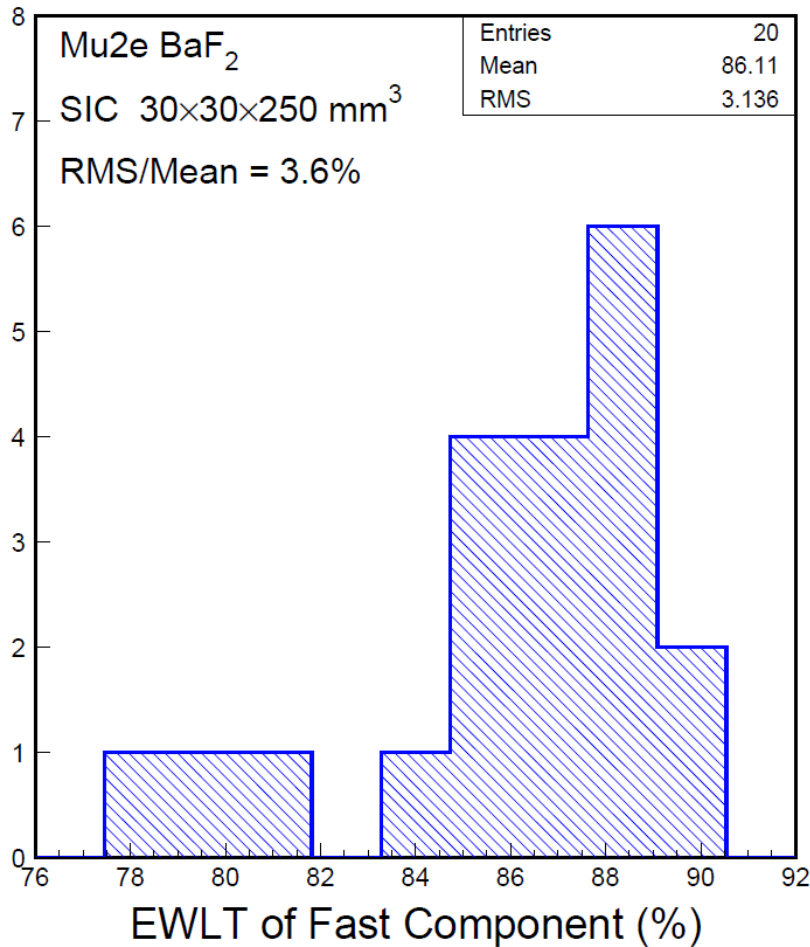

# Setup for PHS, LO and Decay Measurement

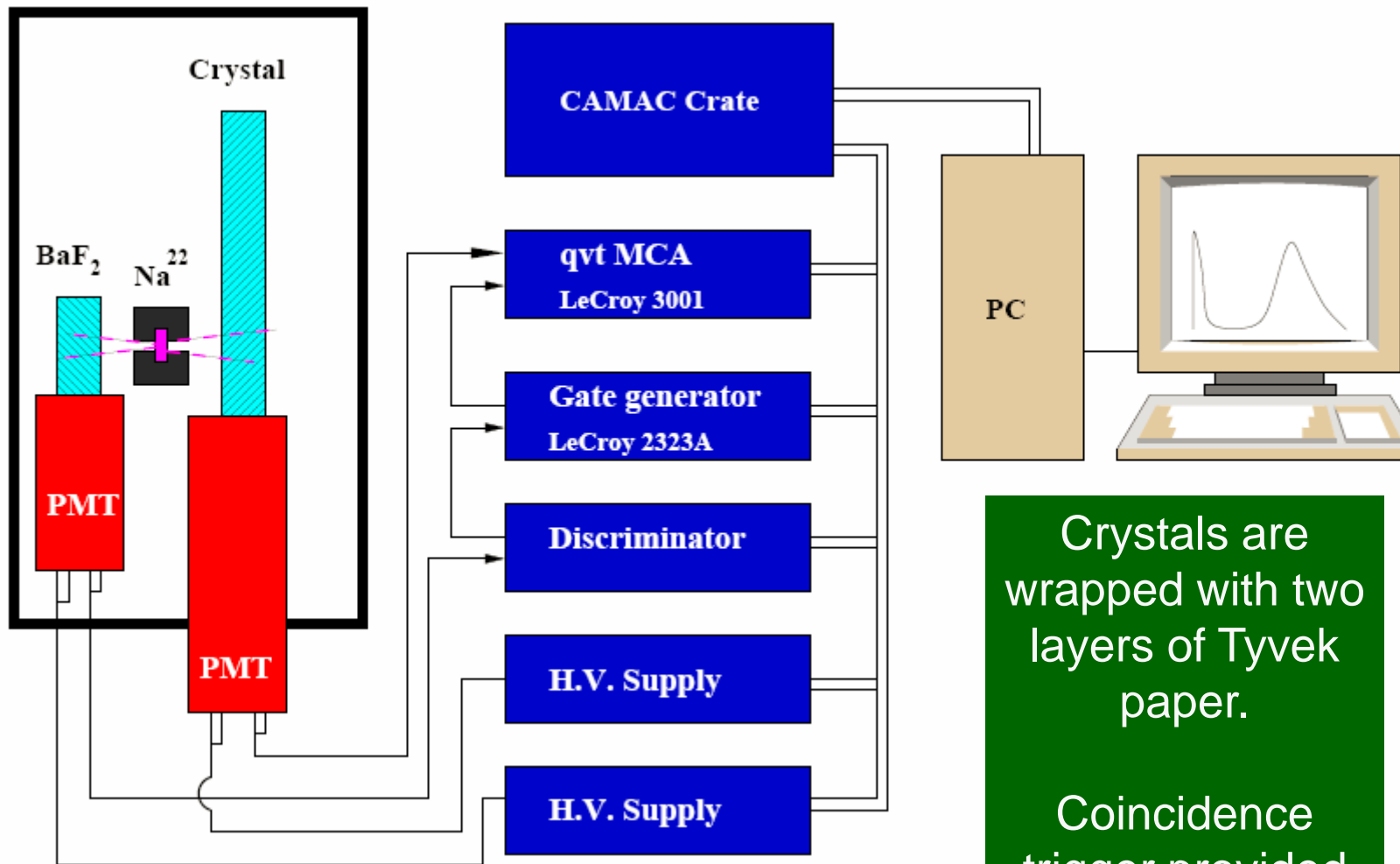

Crystals are wrapped with two layers of Tyvek paper.

Coincidence trigger provided by a  $^{22}\text{Na}$  source.

# Example of Pulse Height Spectra

2.5  $\mu\text{s}$  gate sees 2.3 times better resolution than 50 ns gate

Average ER = 41.7% with 50 ns gate

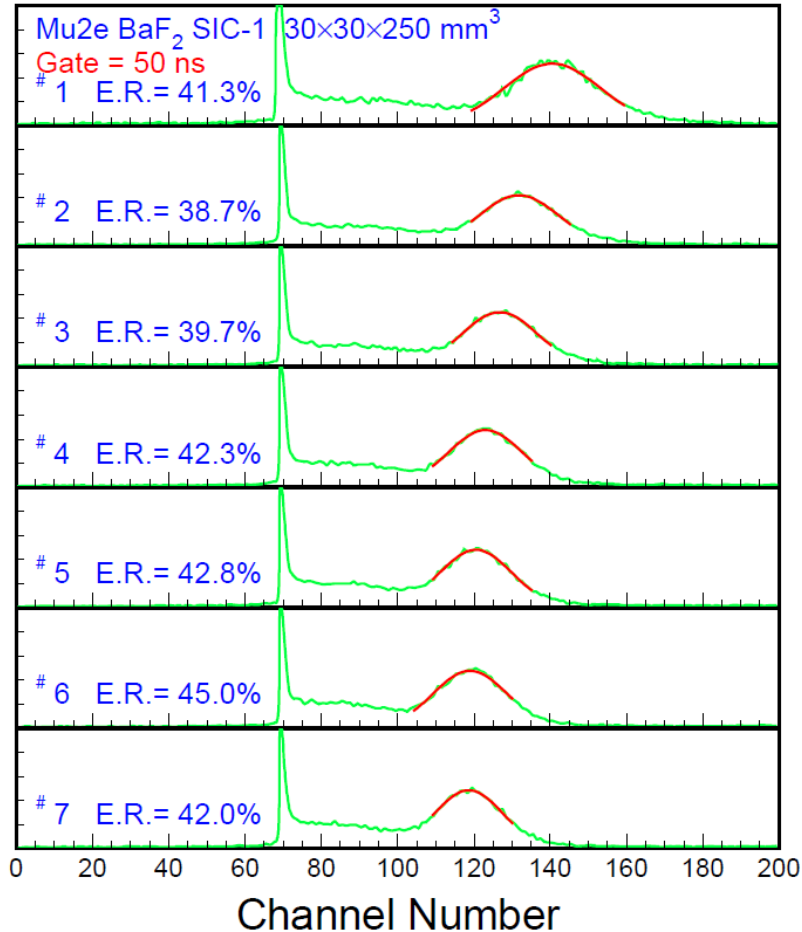

Average ER = 17.8% with 2.5  $\mu\text{s}$  gate

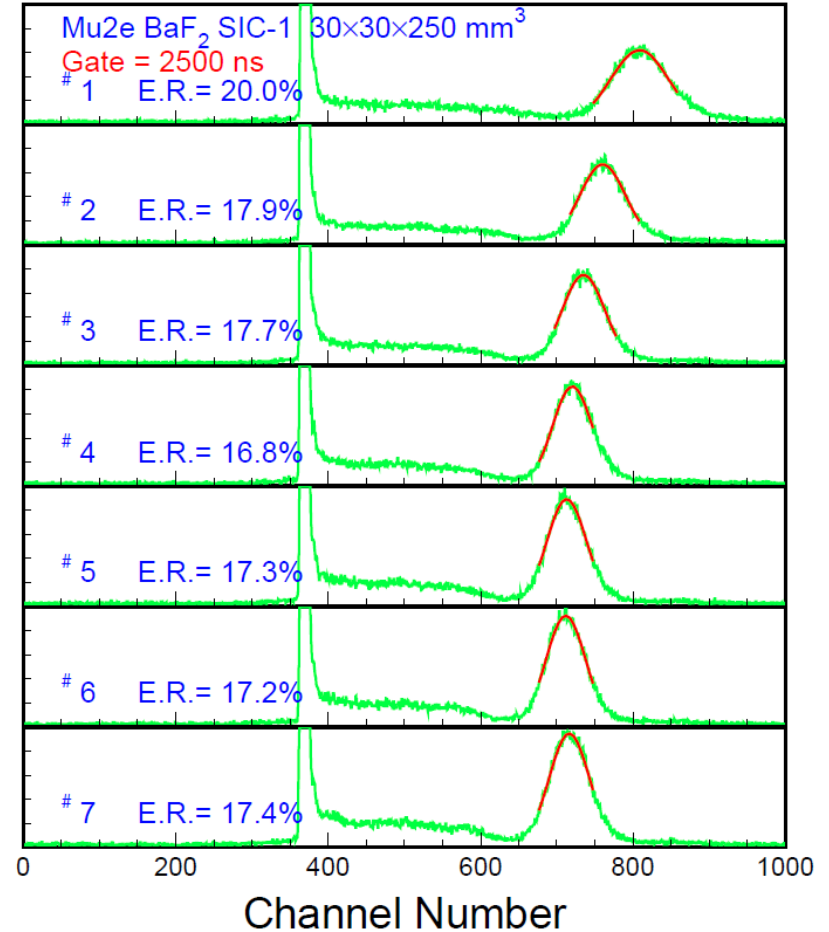



# Summary of ER

Consistency of 5.9% and 5.6% respectively for 50 ns and 2.5  $\mu$ s gate

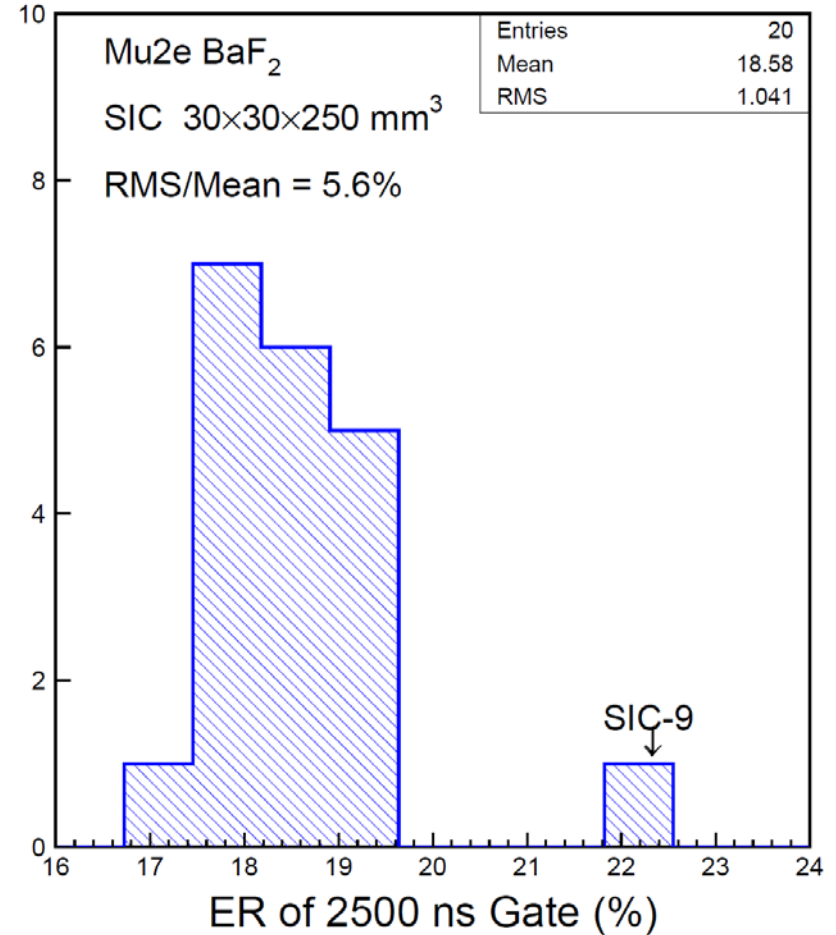
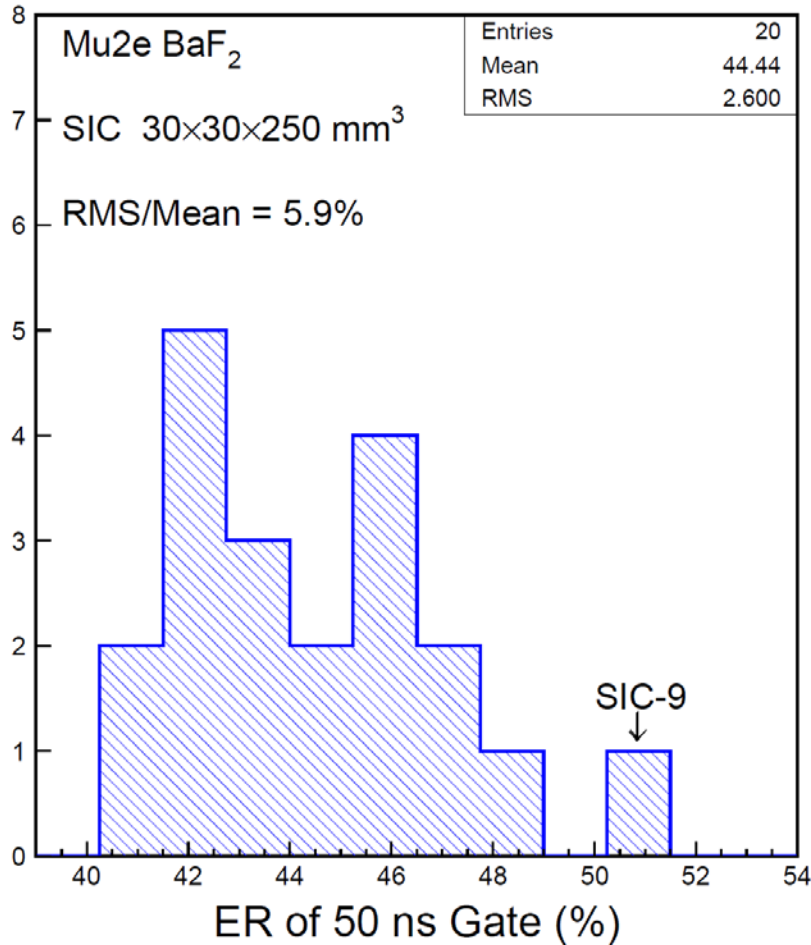

# Decay Kinetics of No.1-10

Consistent fast and slow scintillation component observed

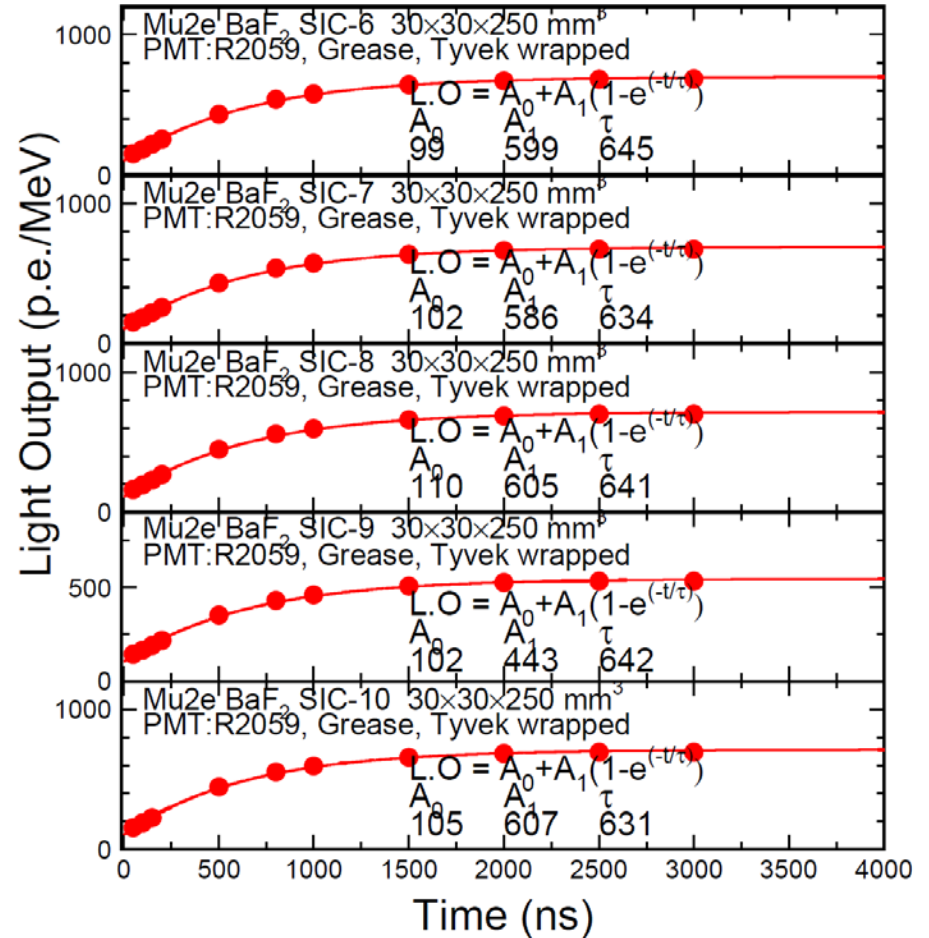
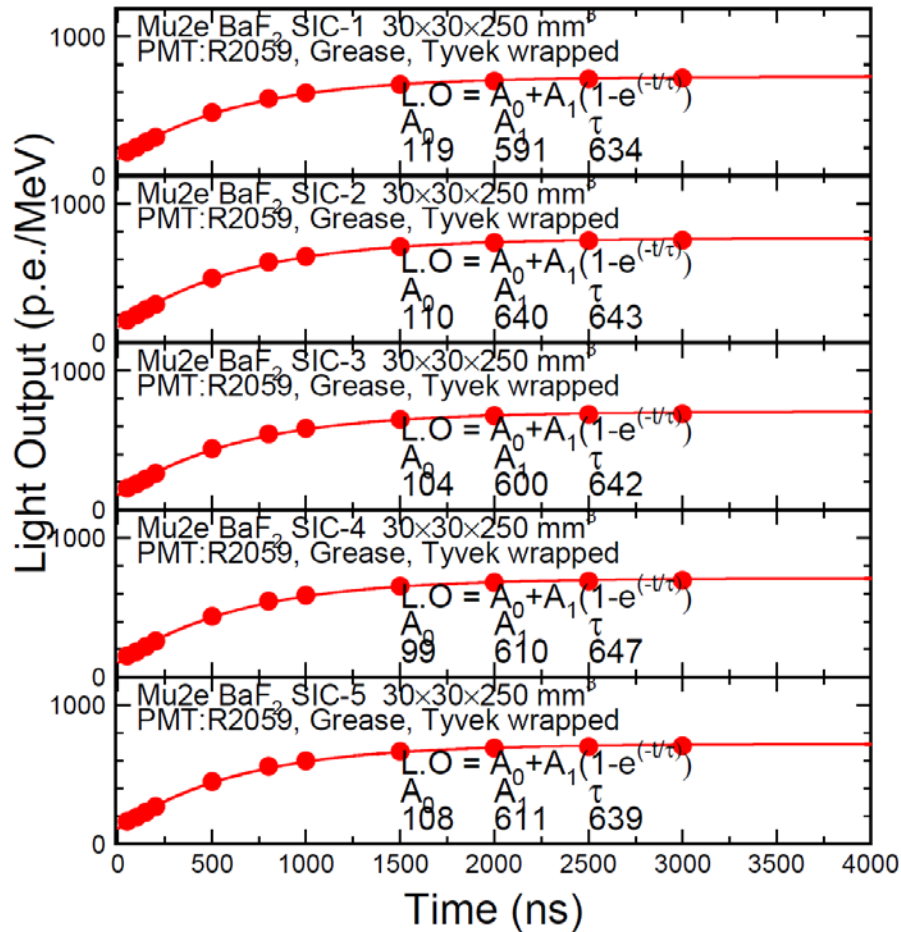

# Decay Kinetics of No.11-20

Consistent fast and slow scintillation component observed

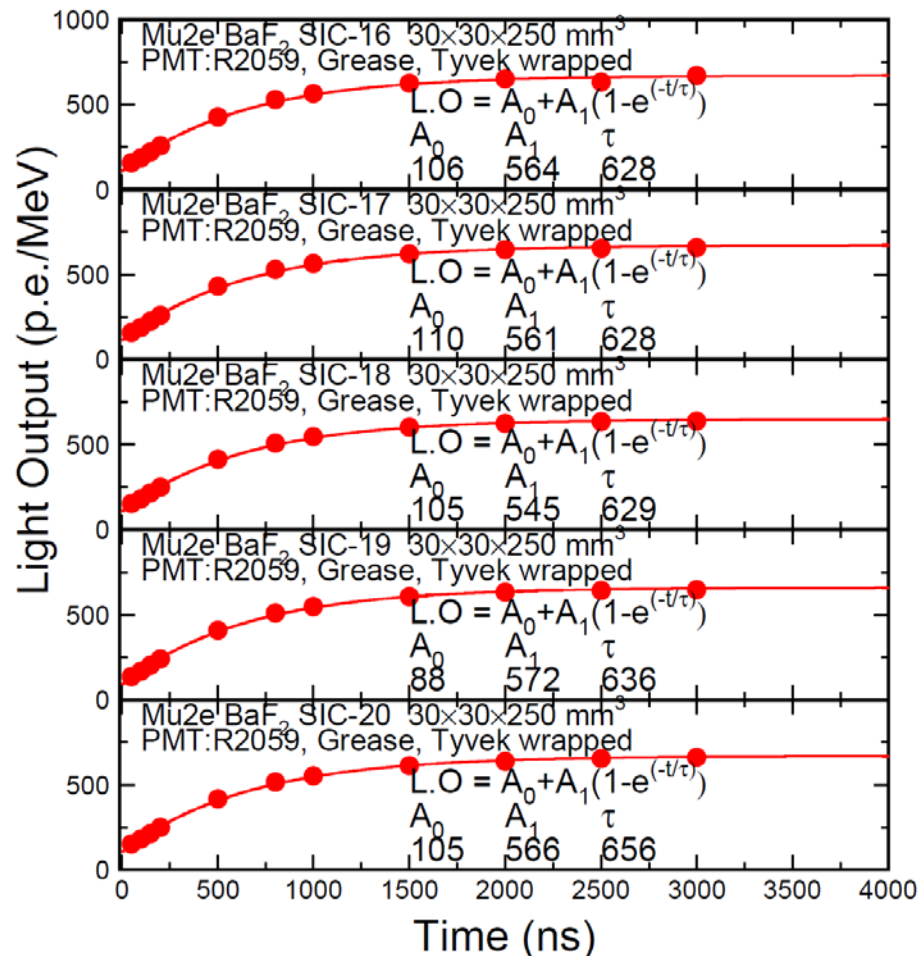
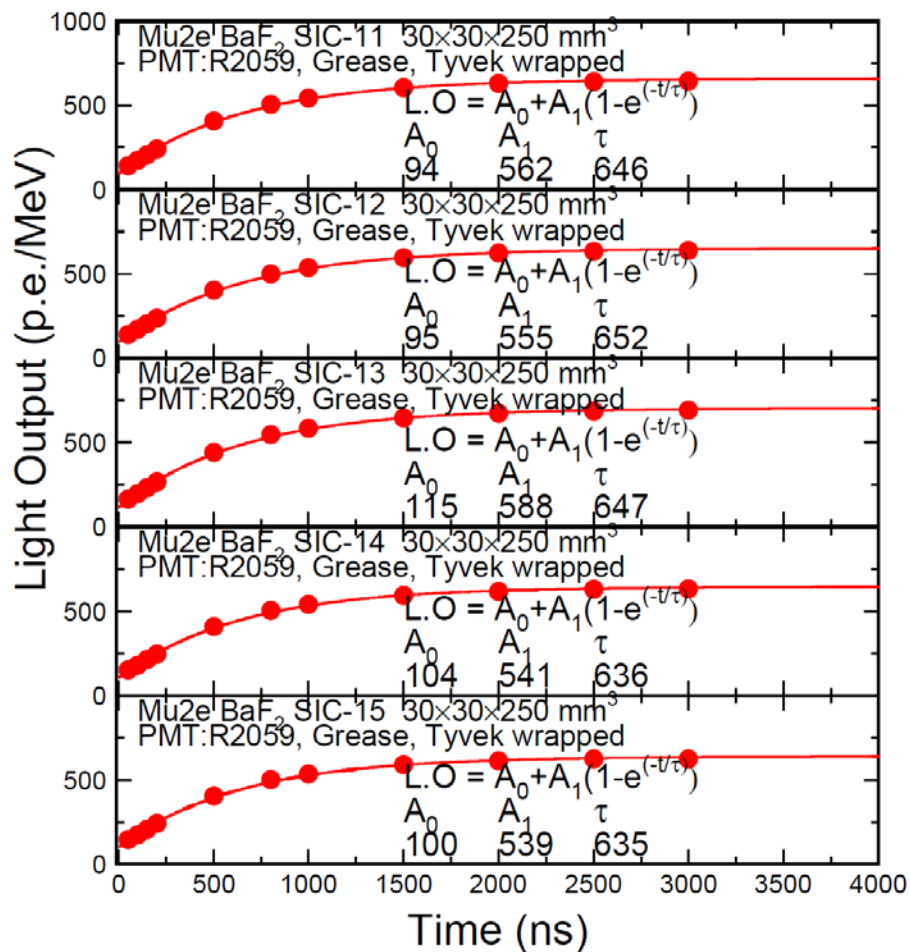

# Summary of Fast and Slow Light Output

7.5% consistency observed

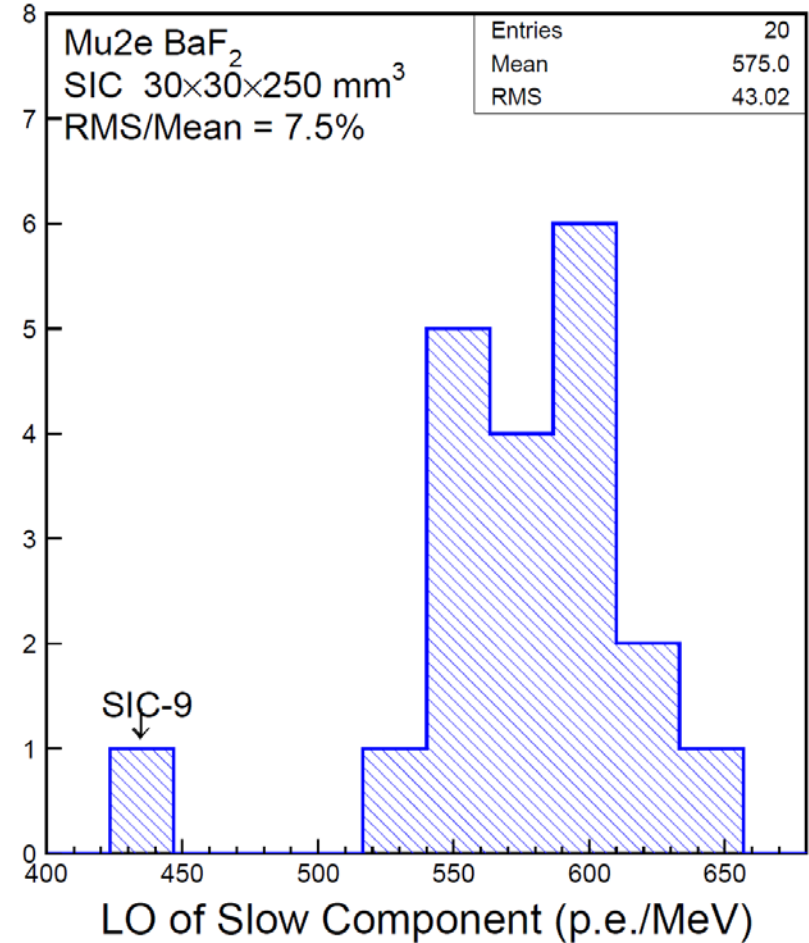
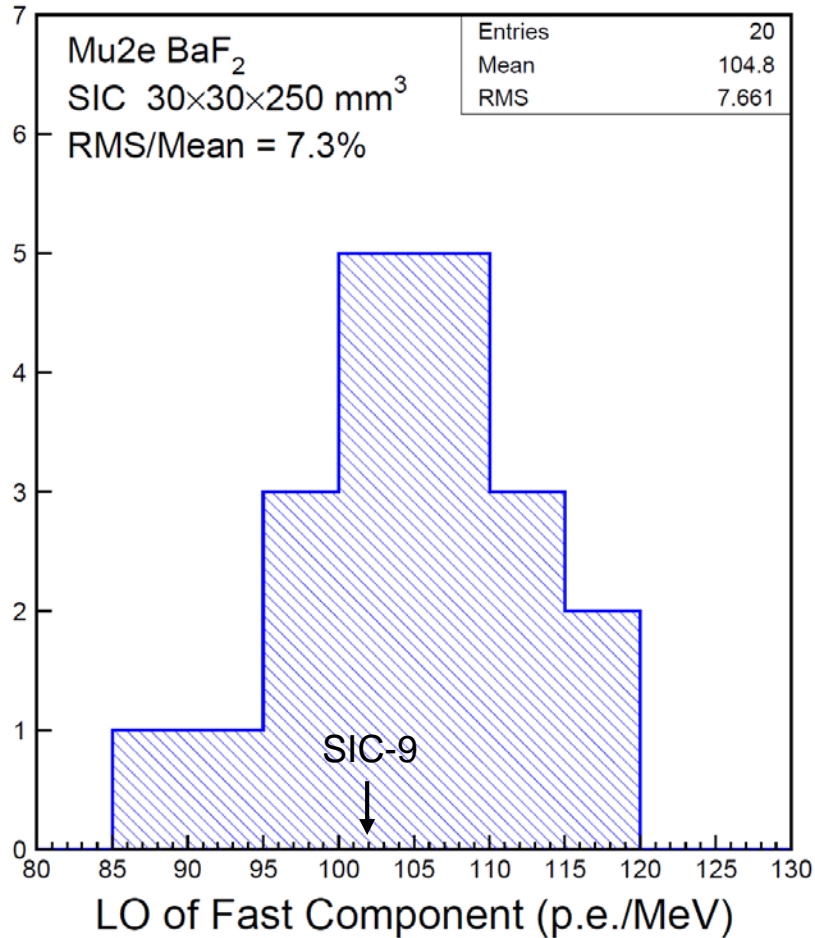

# Summary of Decay Time

Consistency of 1.3% observed for decay time of the slow component

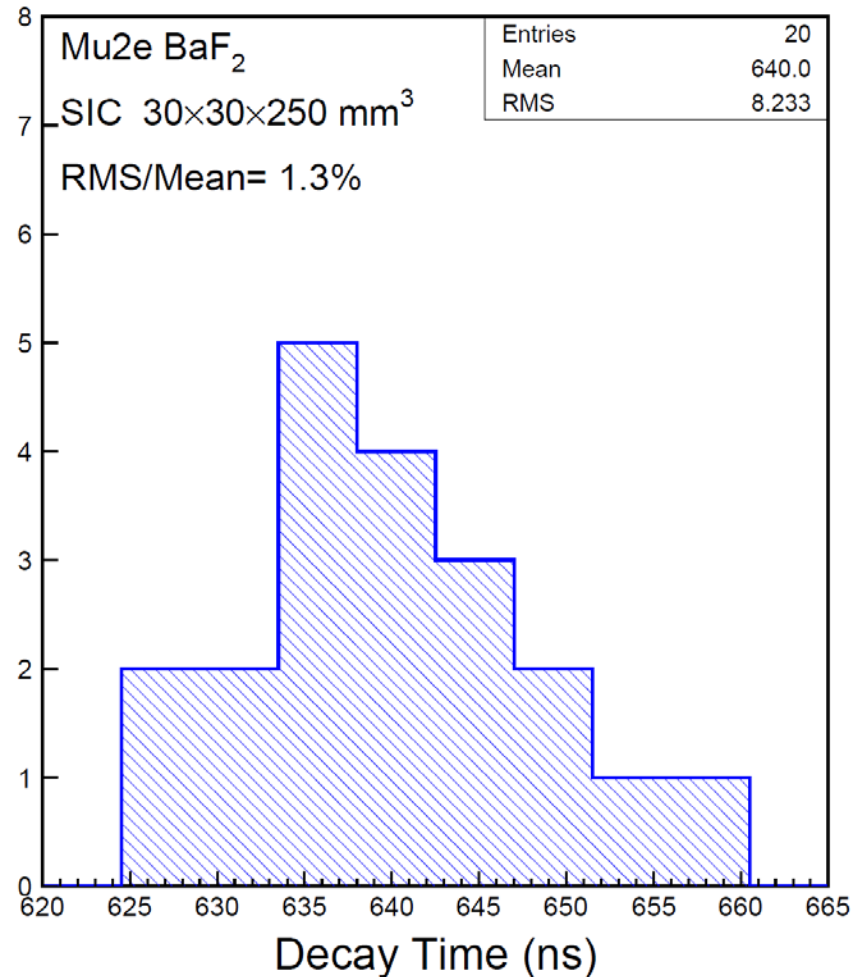

# Effect of Crystal Wrapping

The highest LO observed for crystals wrapped with 8 layer Teflon films

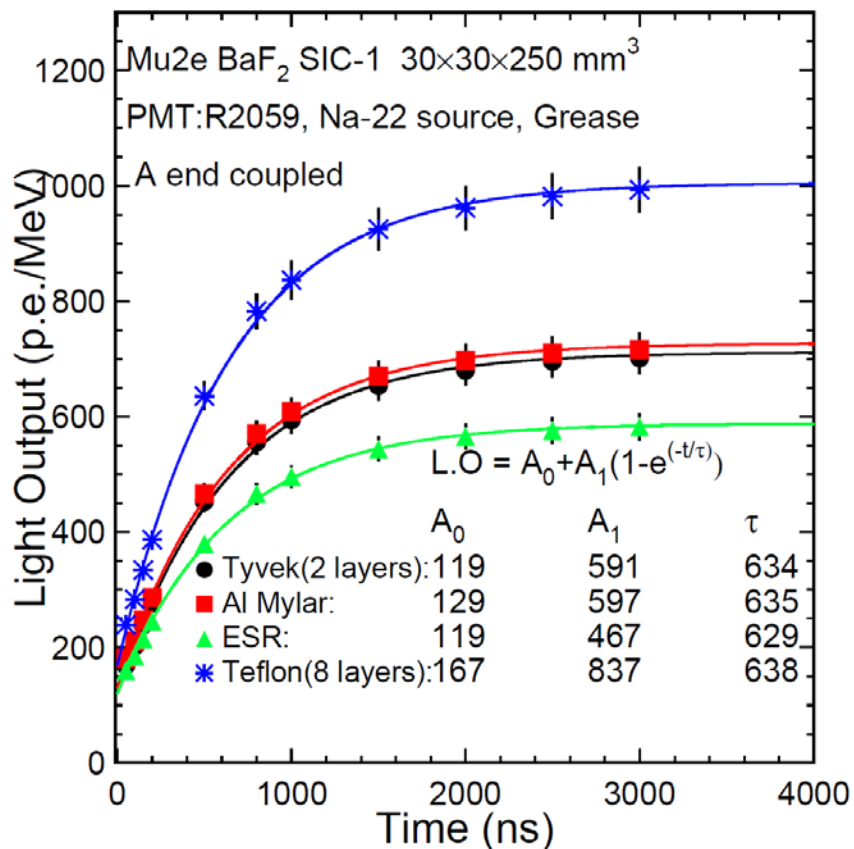

Additional Al foil does not increase LO

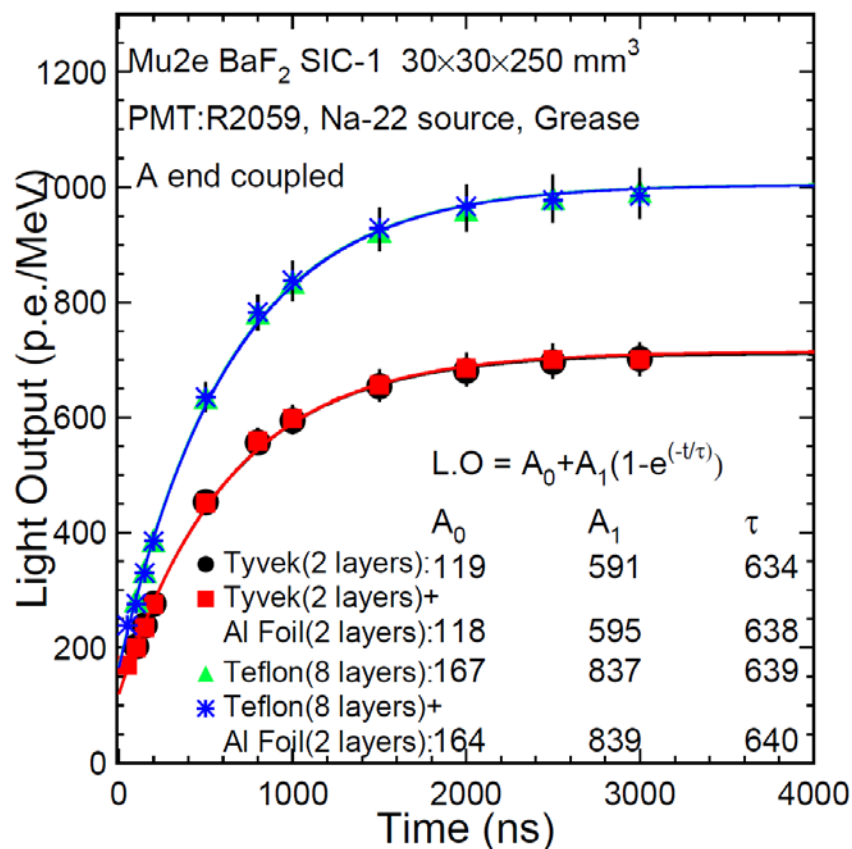

# Summary

- Good optical quality with consistency of 4% and 3% at 220 nm and 300 nm respectively is observed.
- By using a PMT with a bi-alkali cathode and a quartz window and coincidence trigger from a  $^{22}\text{Na}$  source, crystals wrapped with two layers Tyvek paper show:
  - FWHM energy resolution of 45/19% for 50 ns/2.5  $\mu\text{s}$  integration.
  - Light output of 105/575 p.e./MeV for the fast/slow component.
  - Overall consistency of light output of 7.5%.
- Initial trying with existing wrapping material shows the following order in light output:
  - Eight layer of PTFE Teflon film (8 x 25  $\mu\text{m}$ ), Aluminized Mylar, two layers of Tyvek paper (2 x 150  $\mu\text{m}$  1056D) and ESR.
  - Additional Al foil on Teflon and Tyvek does not help.
  - Test with solid Teflon reflector (6.5 mm thick) is under way.
- Investigation on light response uniformity is under way.

# PHS

Average ER = 43.3%

Average ER = 17.8%

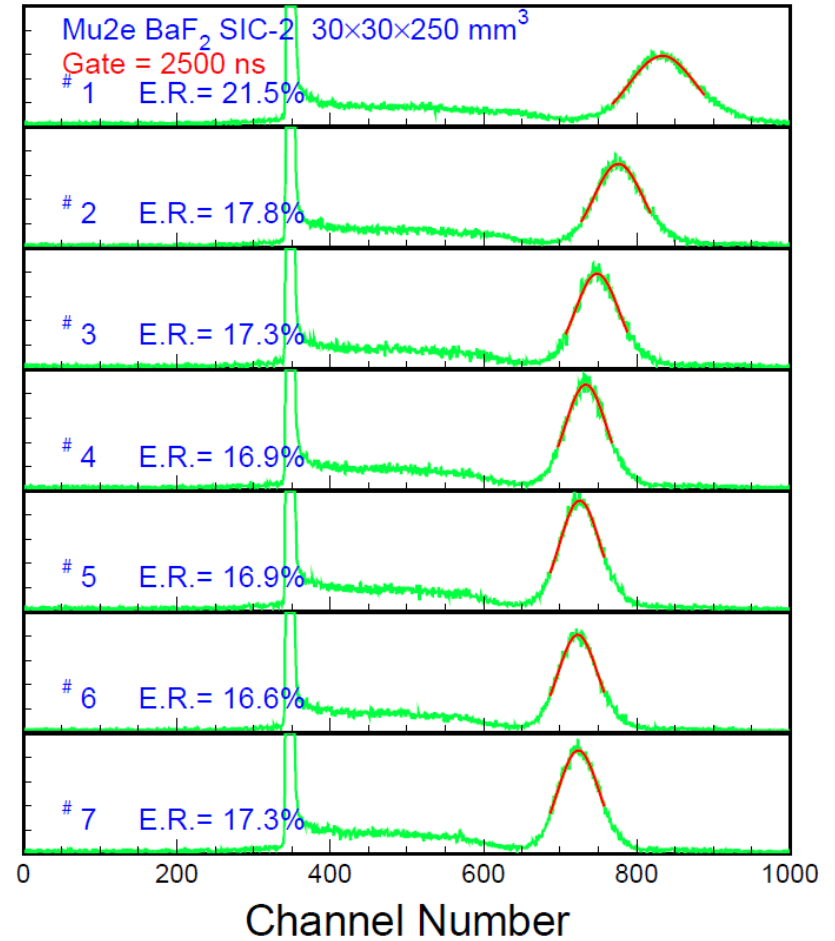
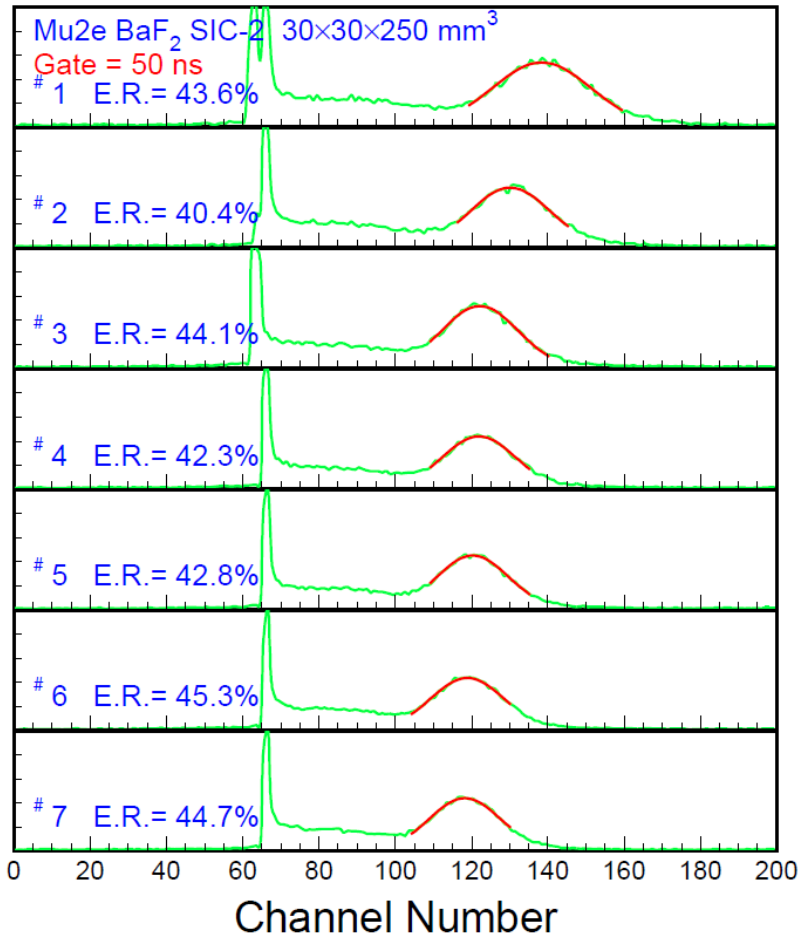



# PHS

Average ER = 46.1%

Average ER = 19.2%

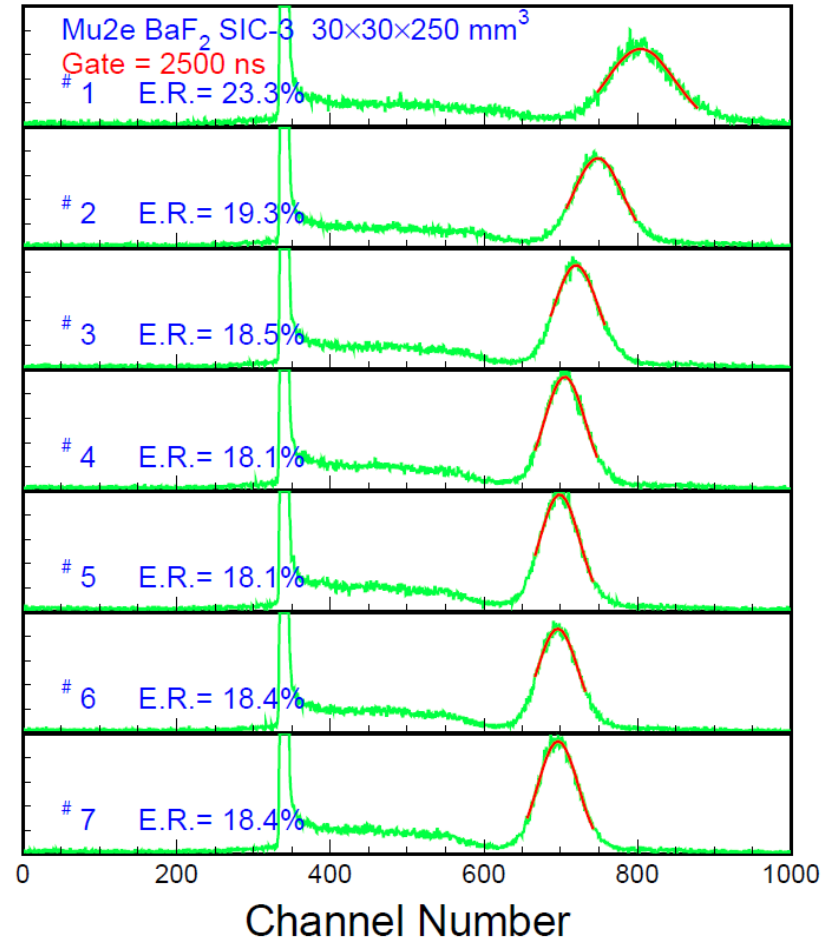
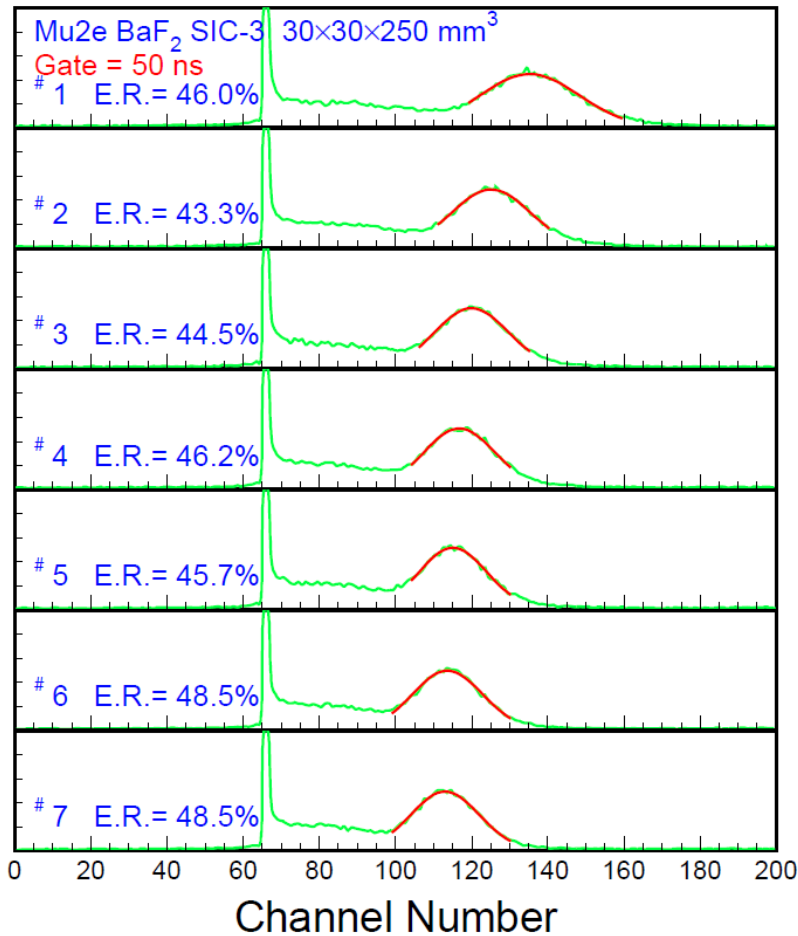

# PHS

Average ER = 48.2%

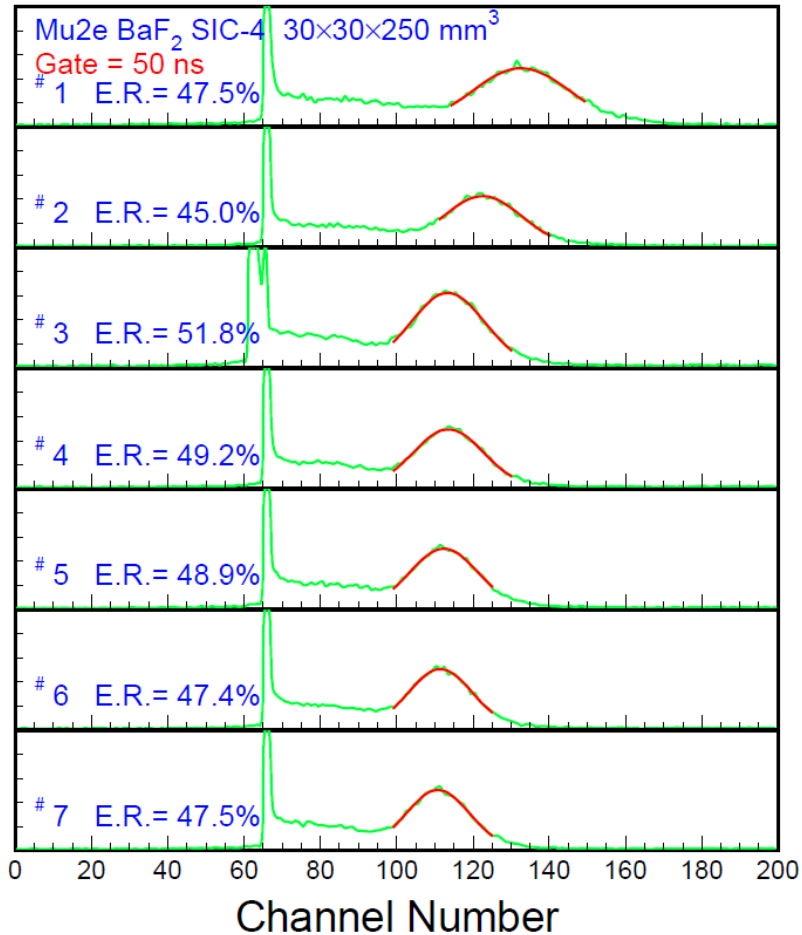

Average ER = 19.1%

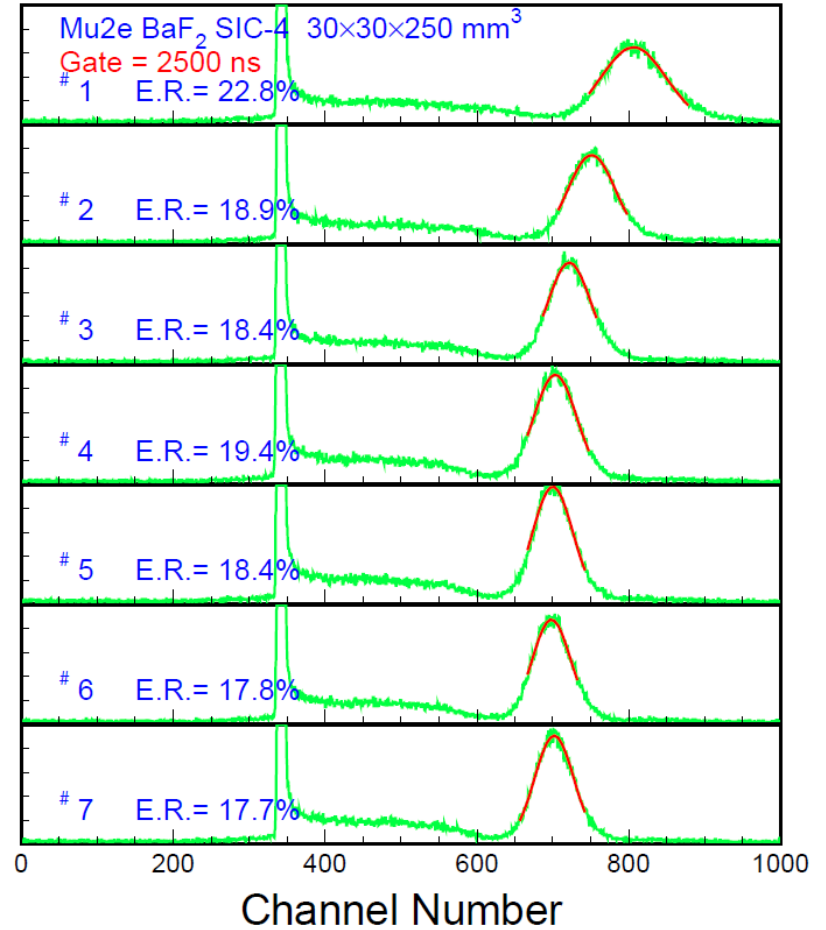

# PHS

Average ER = 44.8%

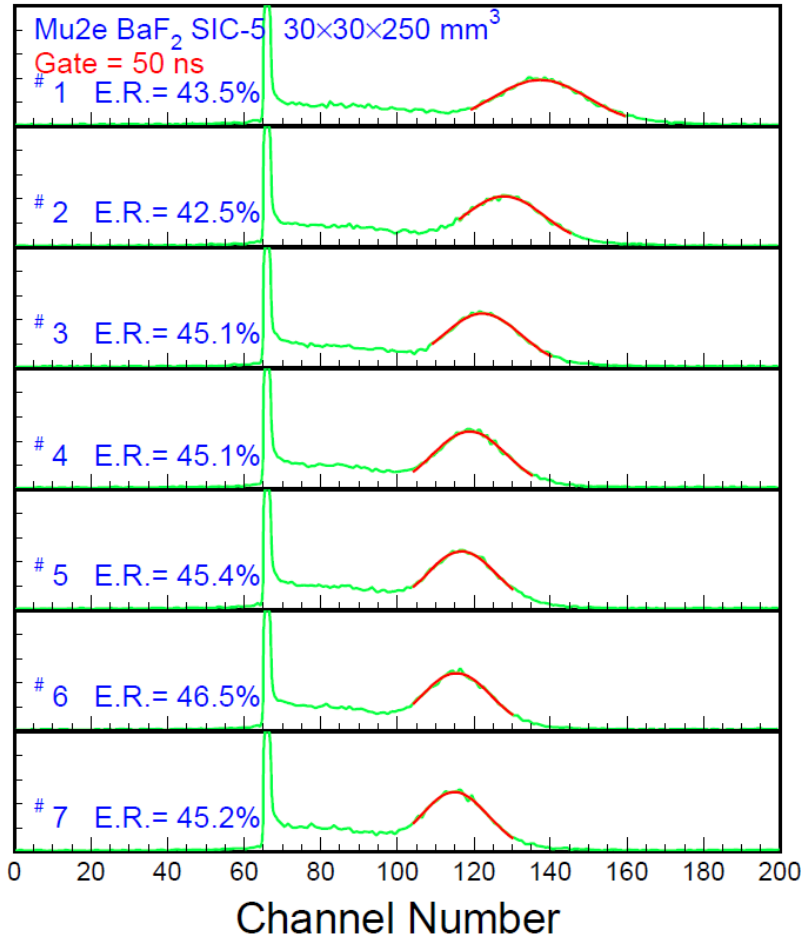

Average ER = 18.3%

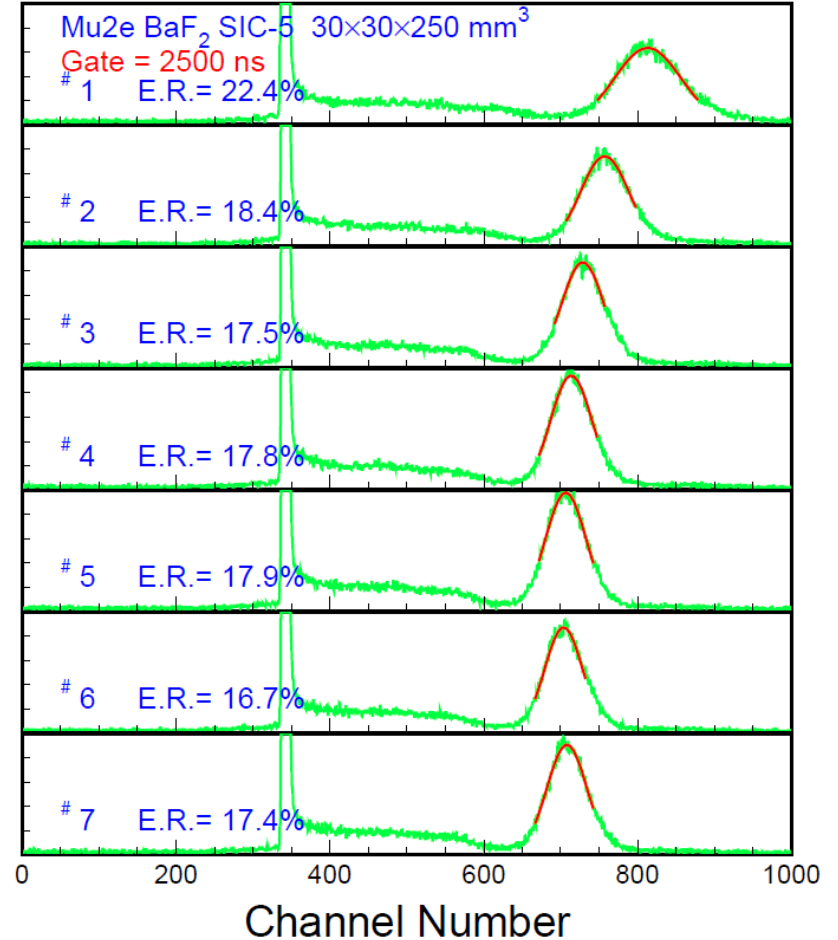

# PHS

Average ER = 46.5%

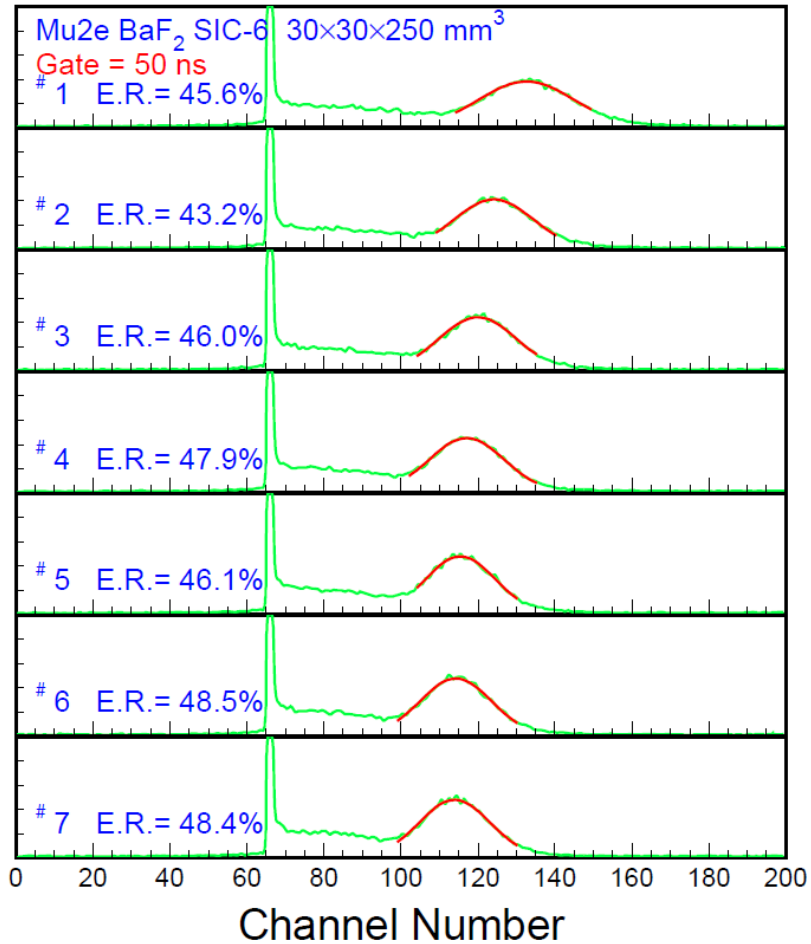

Average ER = 18.8%

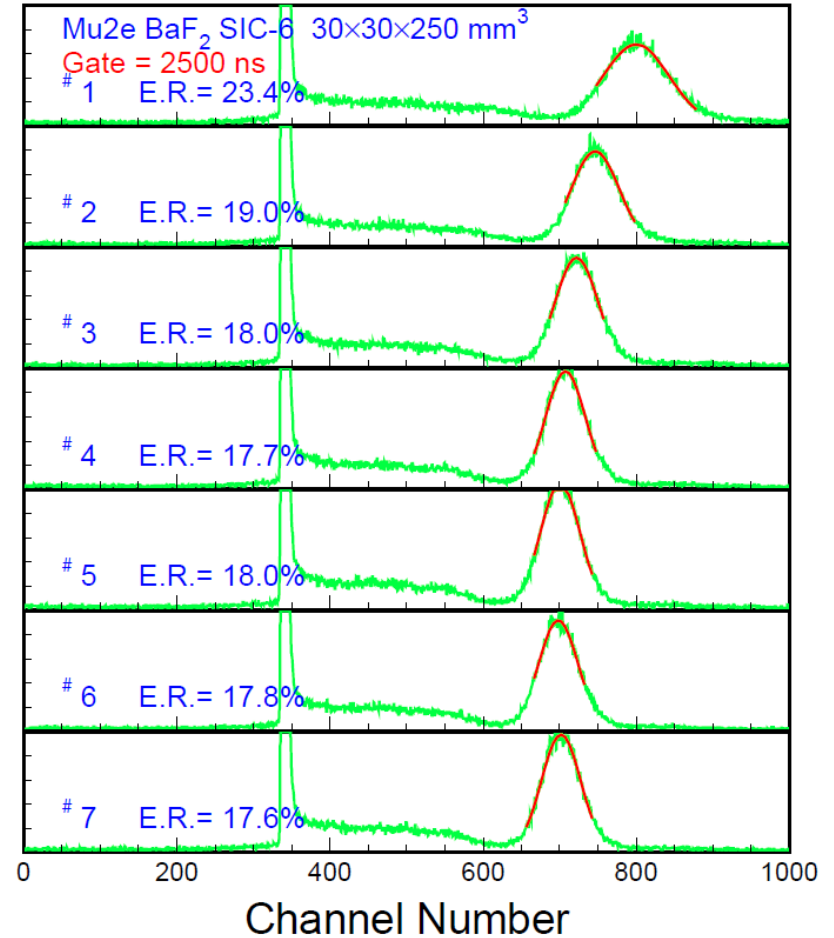

# PHS

Average ER = 47.2%

Average ER = 19.4%

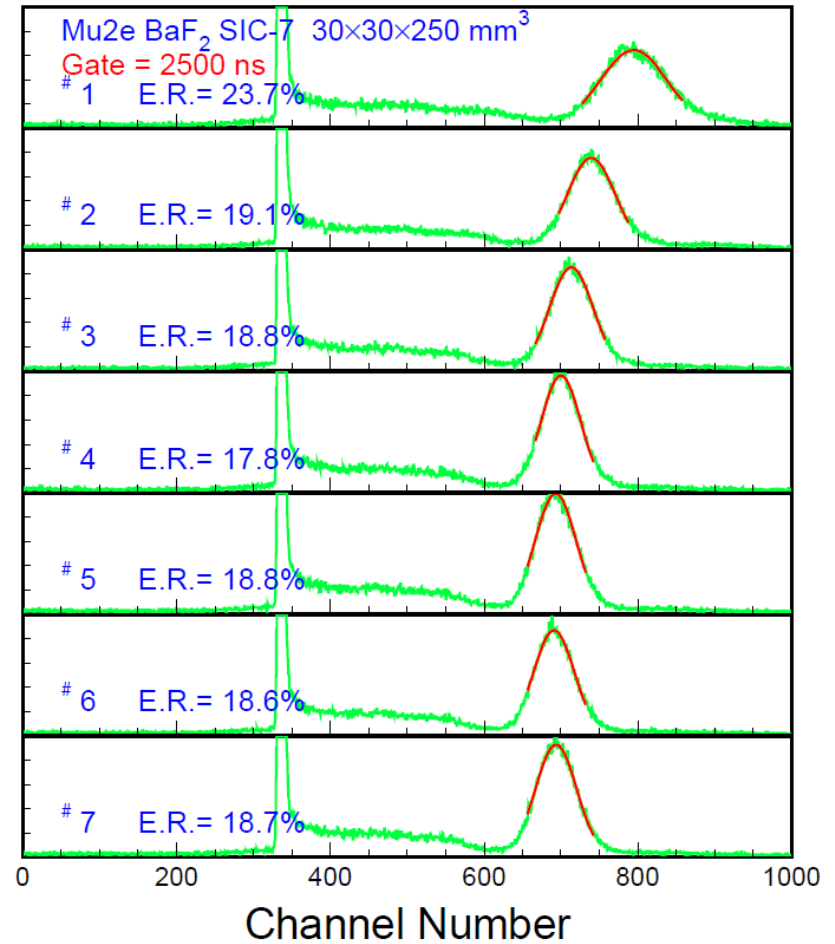
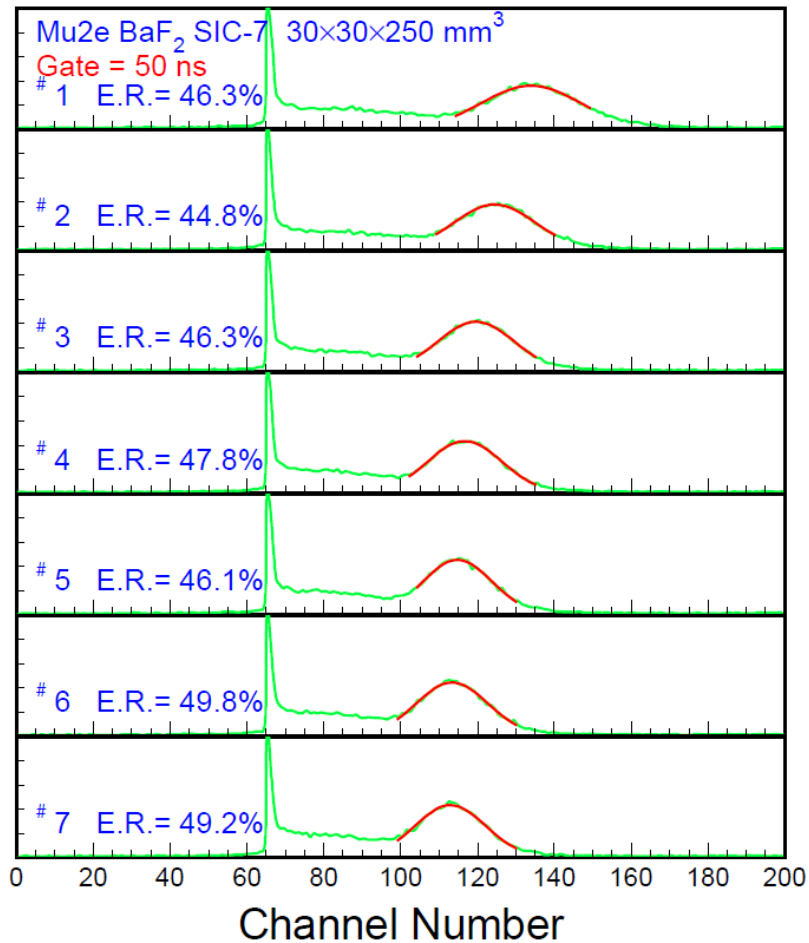

# PHS

Average ER = 43.6%

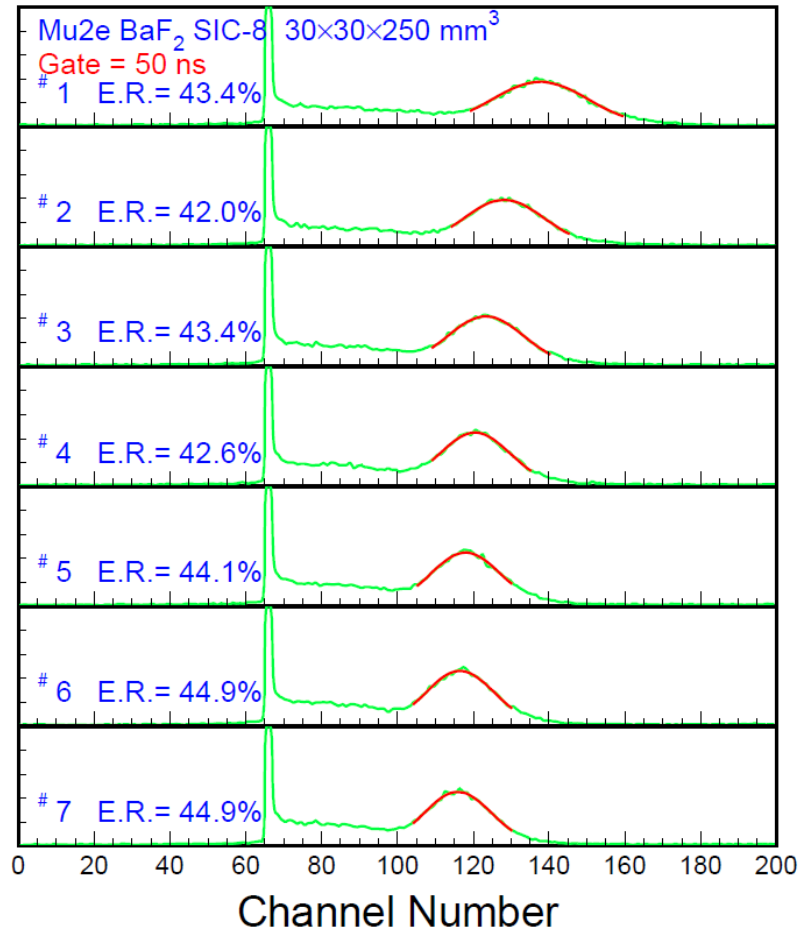

Average ER = 18.5%

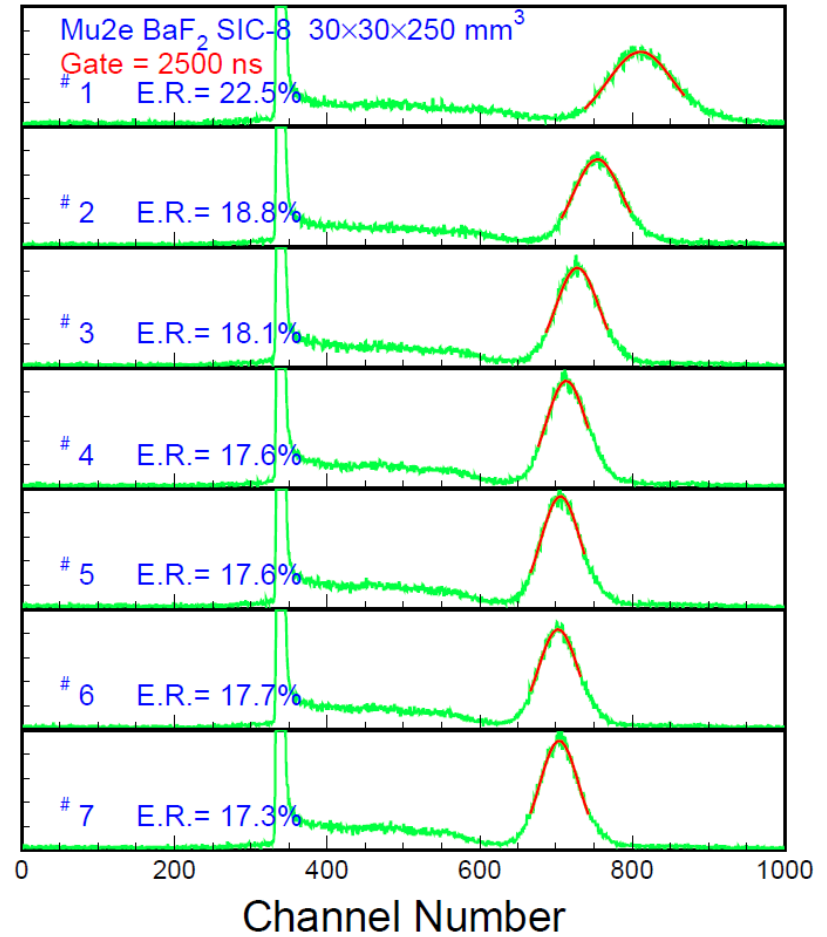

# PHS

Average ER = 51.3%

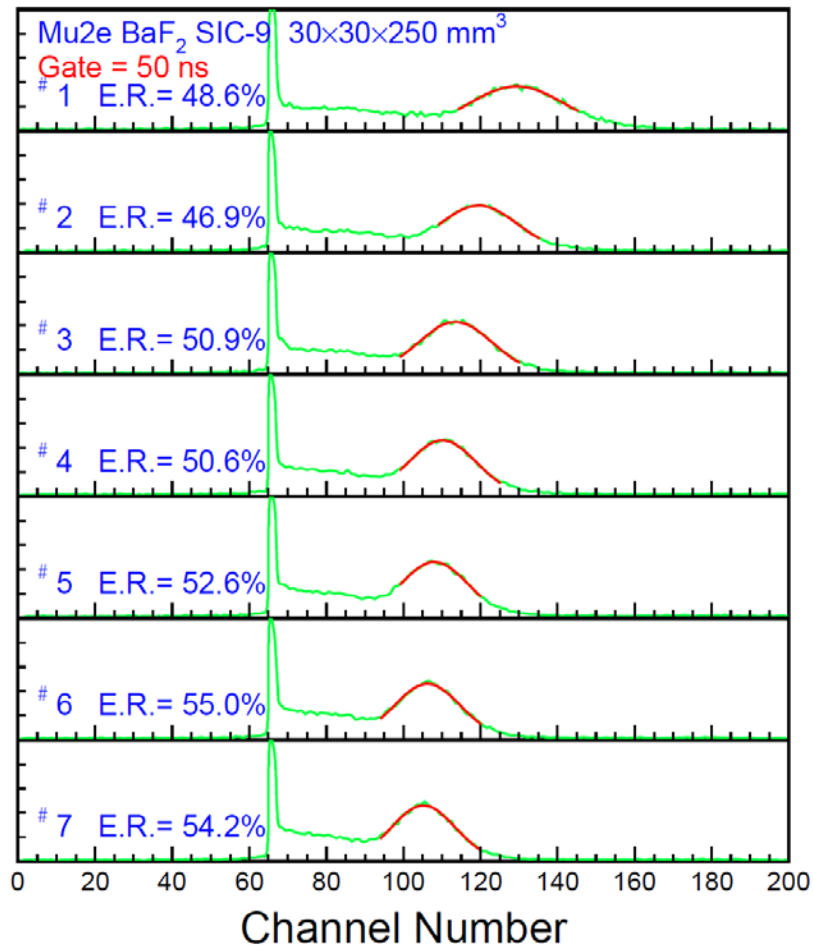

Average ER = 22.4%

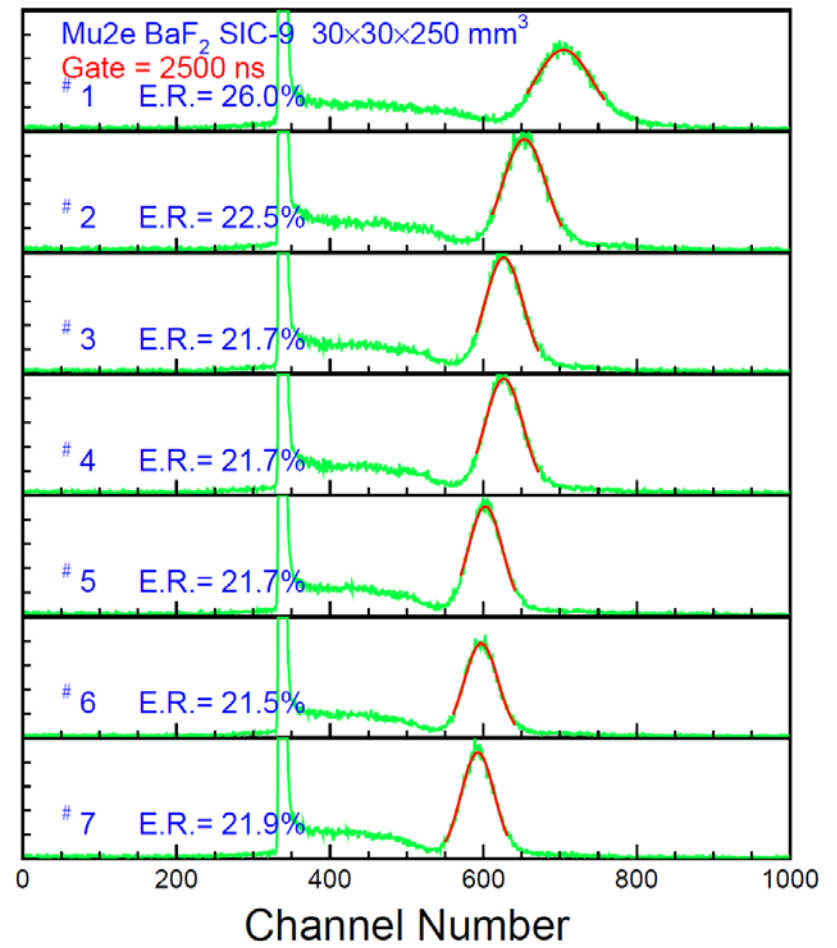

# PHS

Average ER = 45.4%

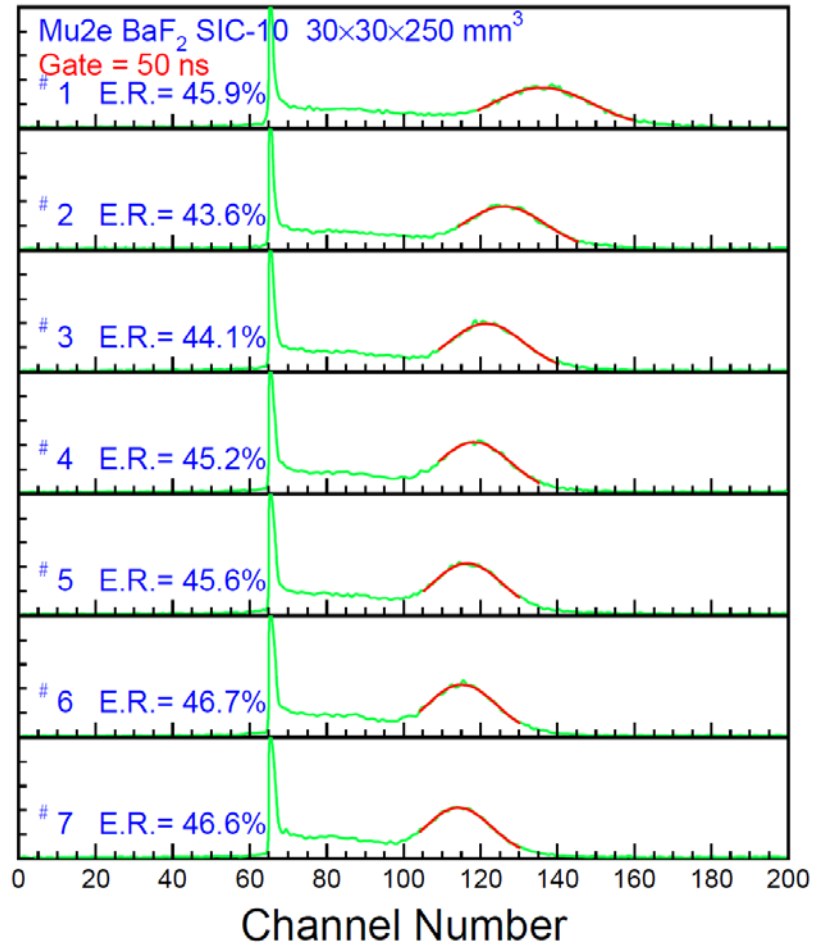

Average ER = 18.6%

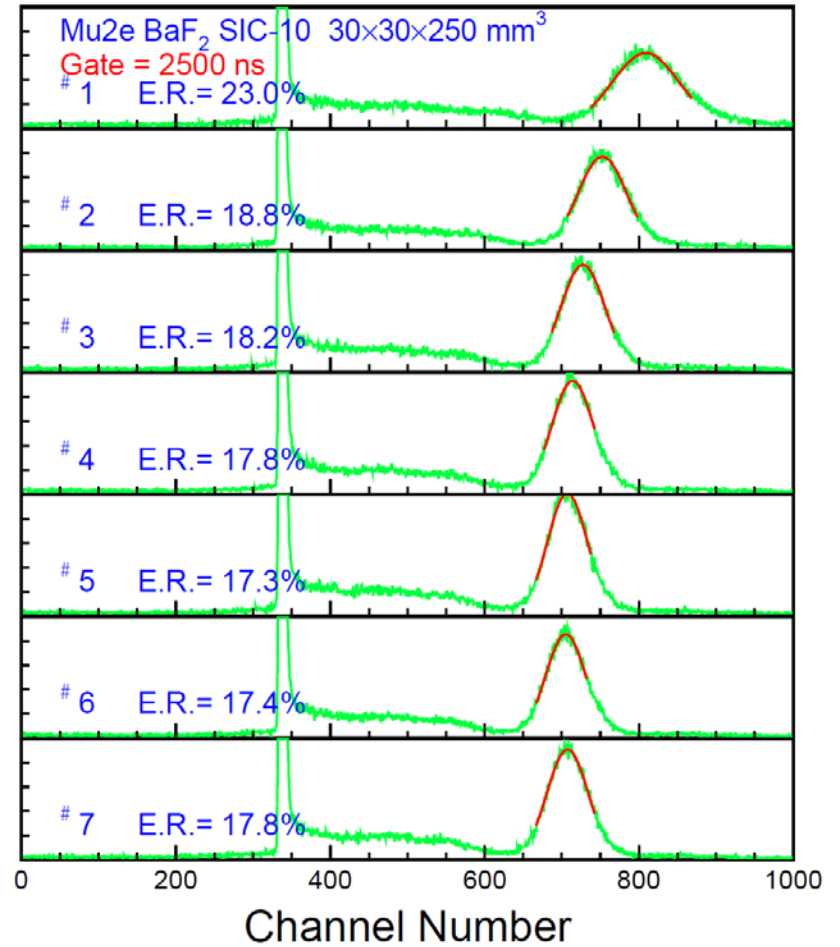



# PHS

Average ER = 45.9%

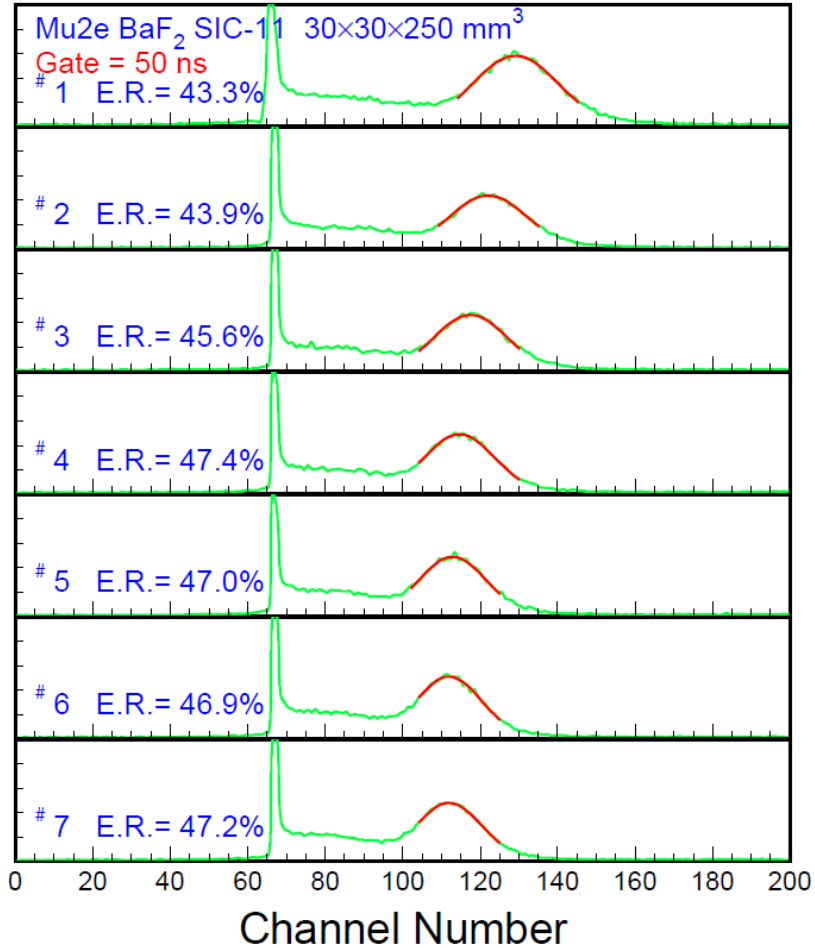

Average ER = 19.0%

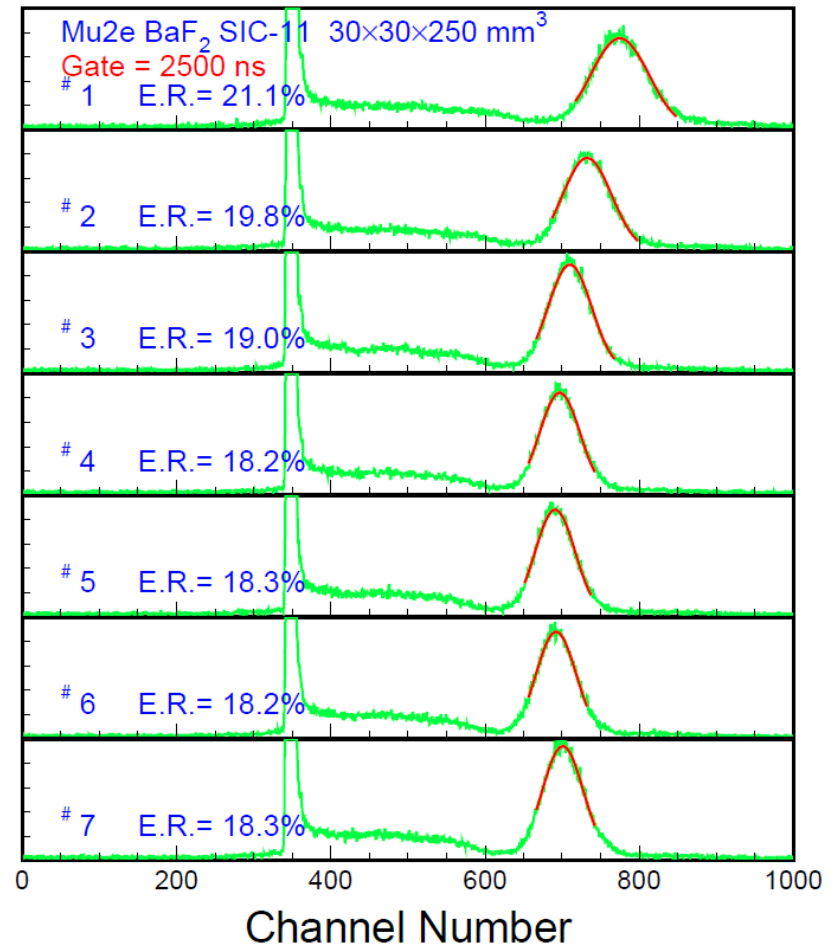

# PHS

Average ER = 45.2%

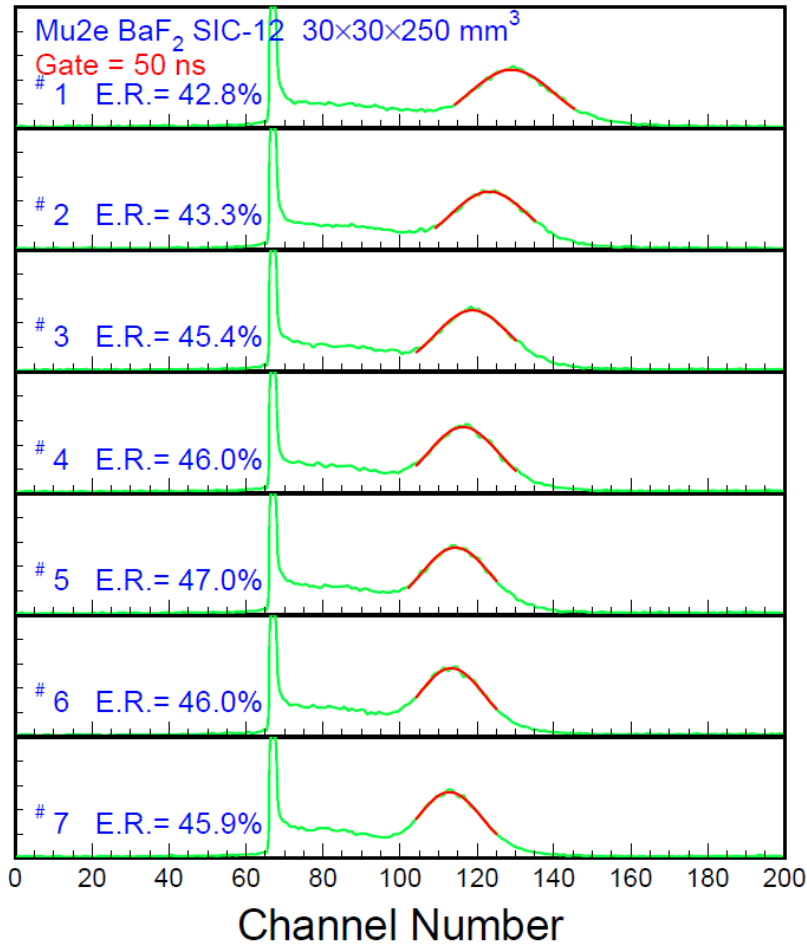

Average ER = 18.8%

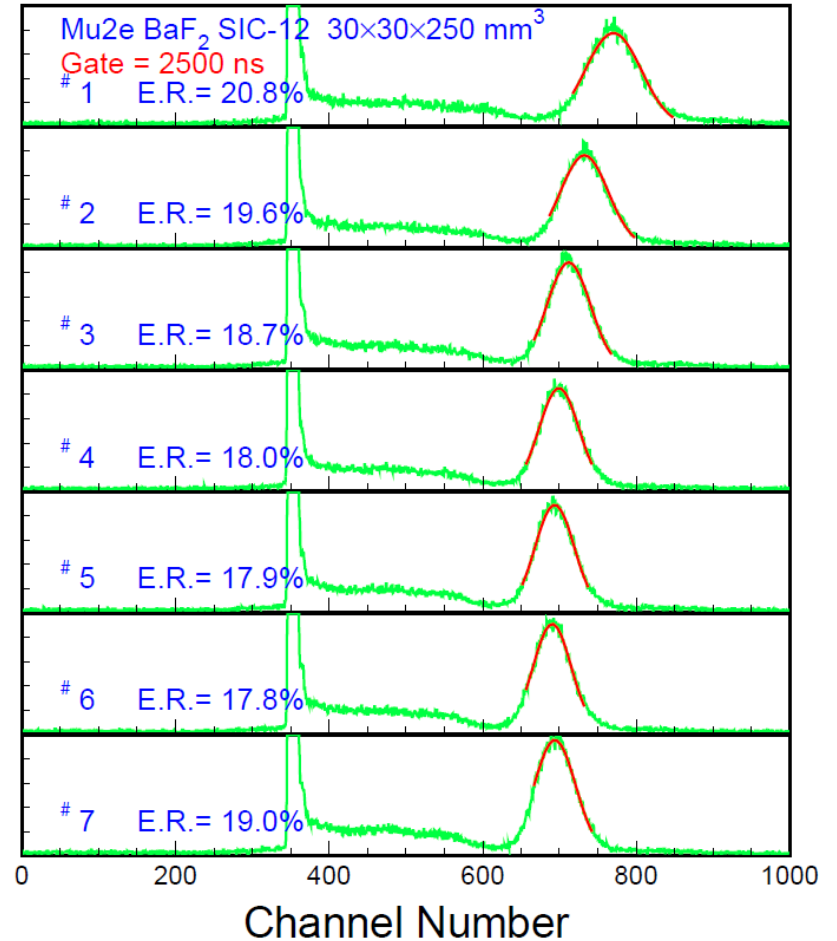

# PHS

Average ER = 40.4%

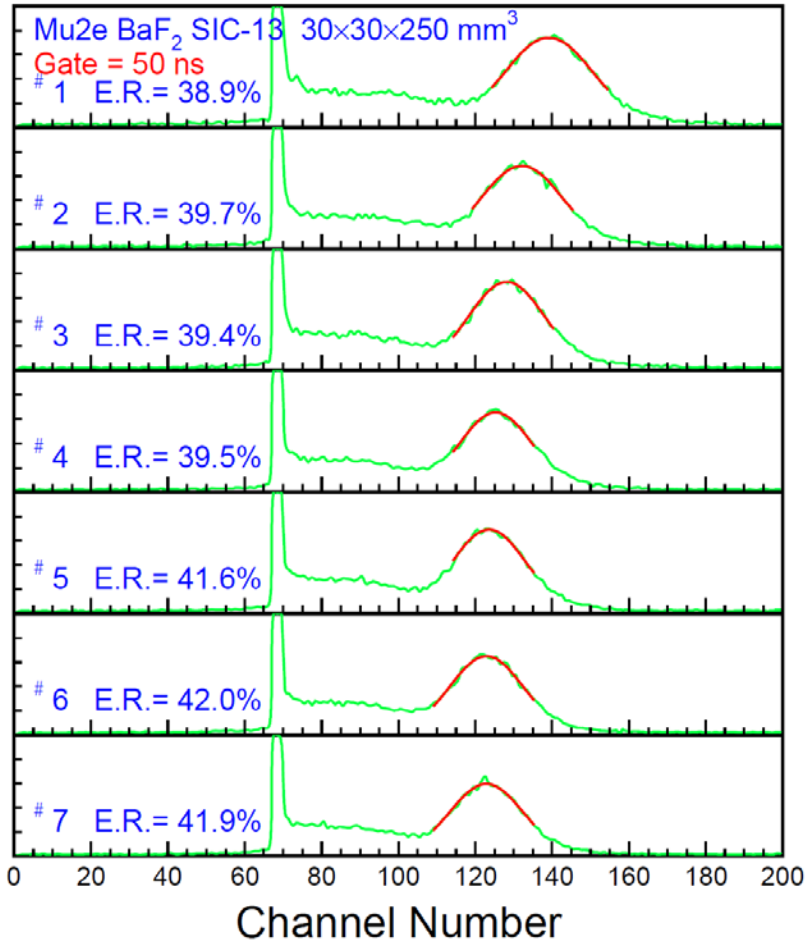

Average ER = 17.2%

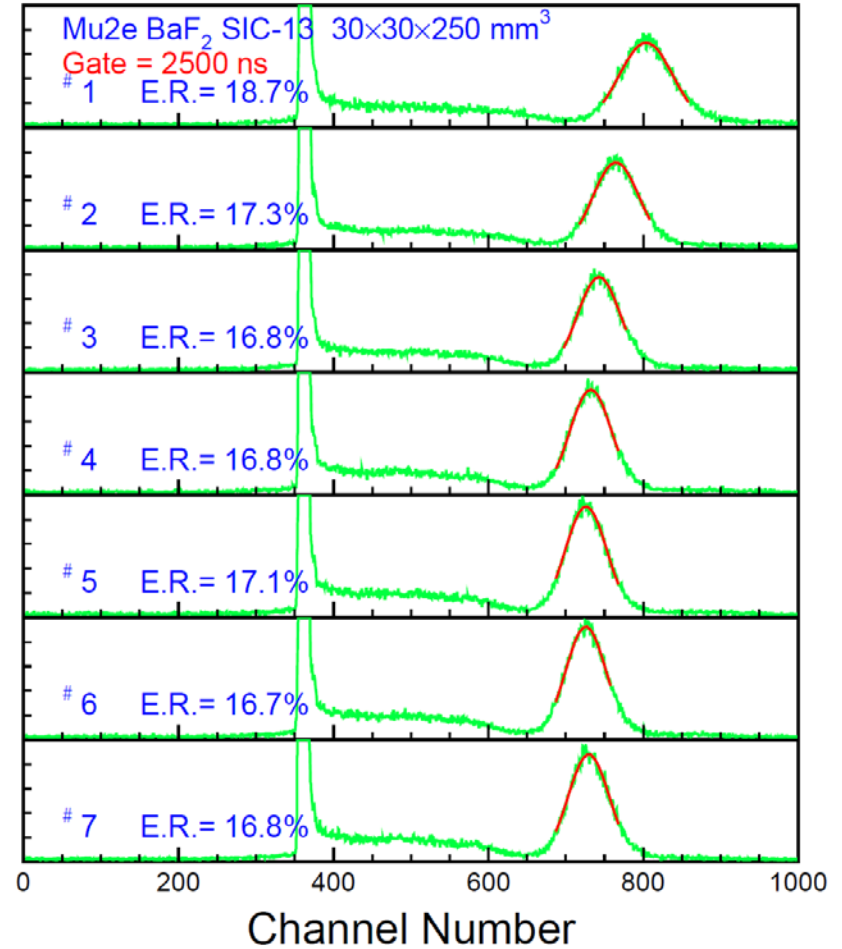

# PHS

Average ER = 42.2%

Average ER = 18.3%

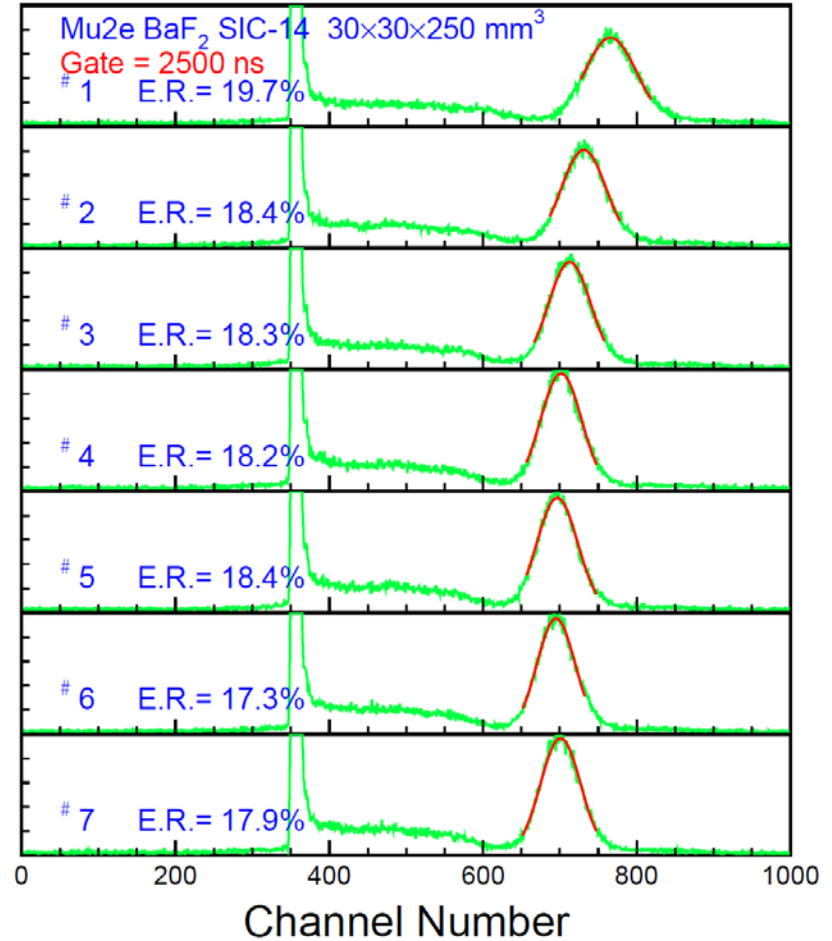
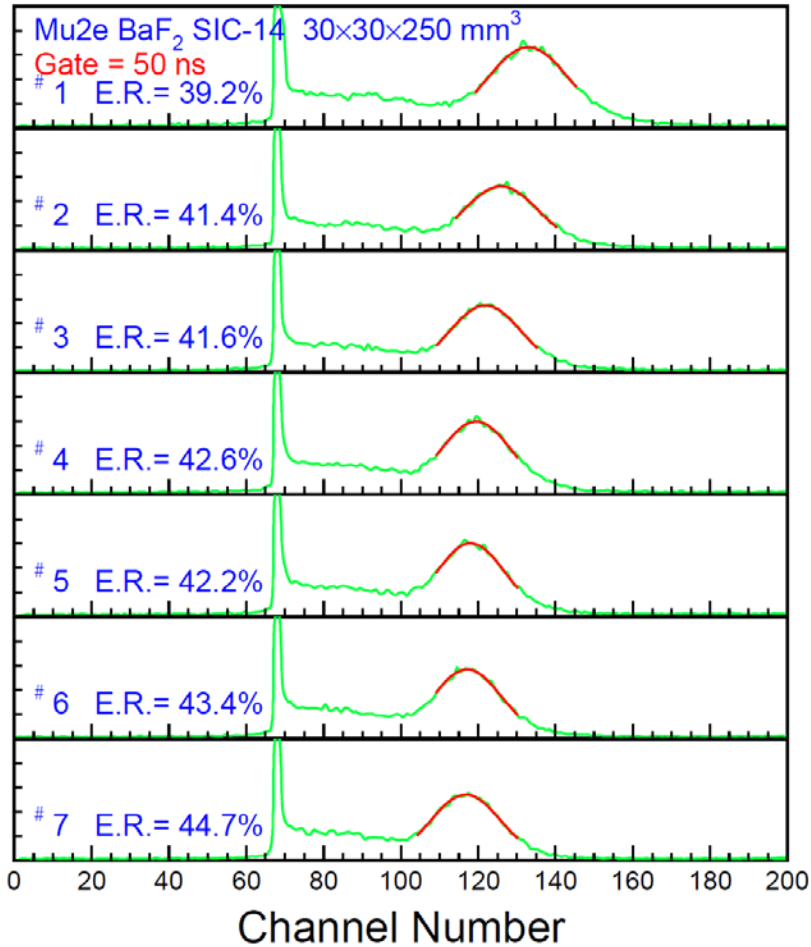

# PHS

Average ER = 45.6%

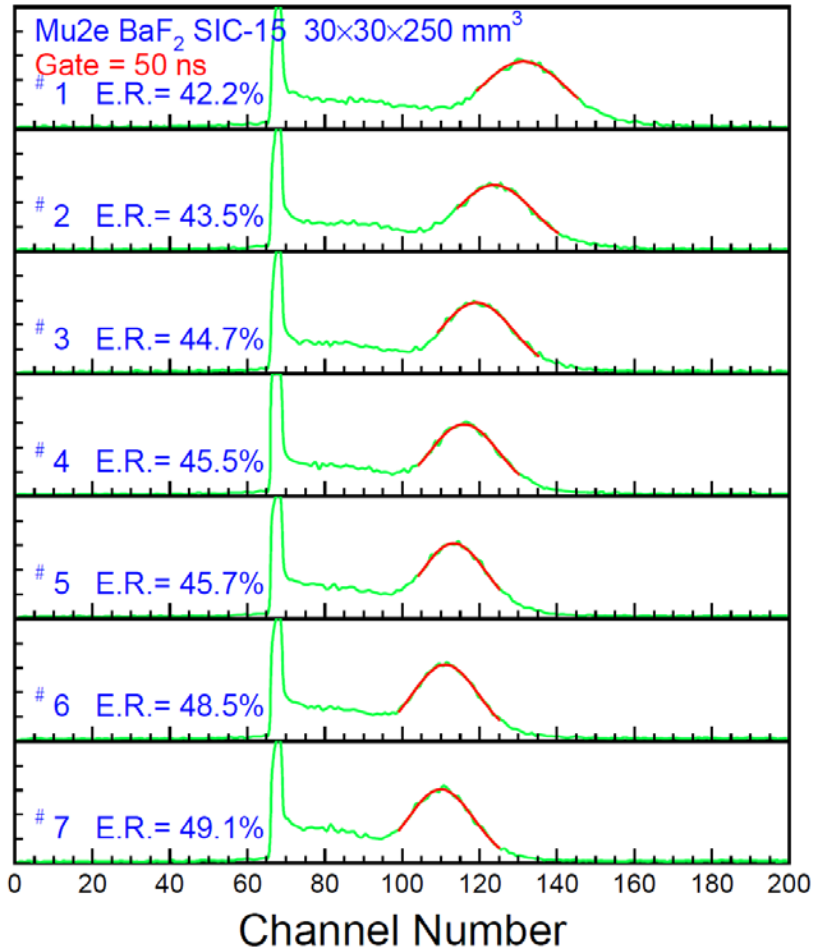

Average ER = 19.2%

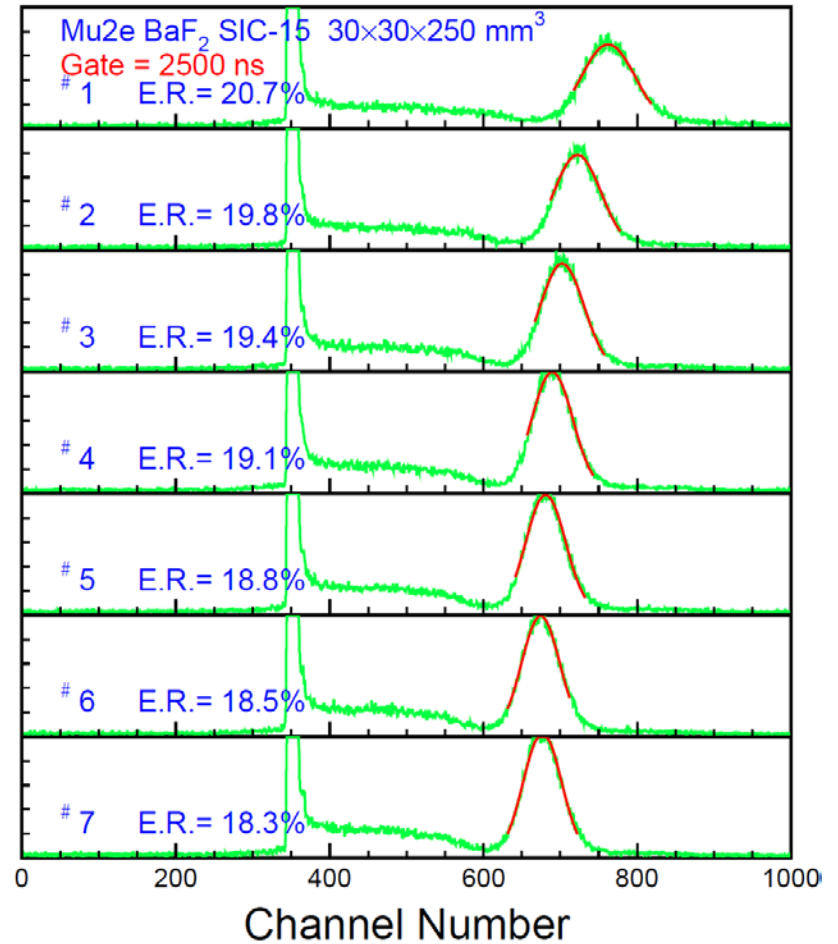

# PHS

Average ER = 42.0%

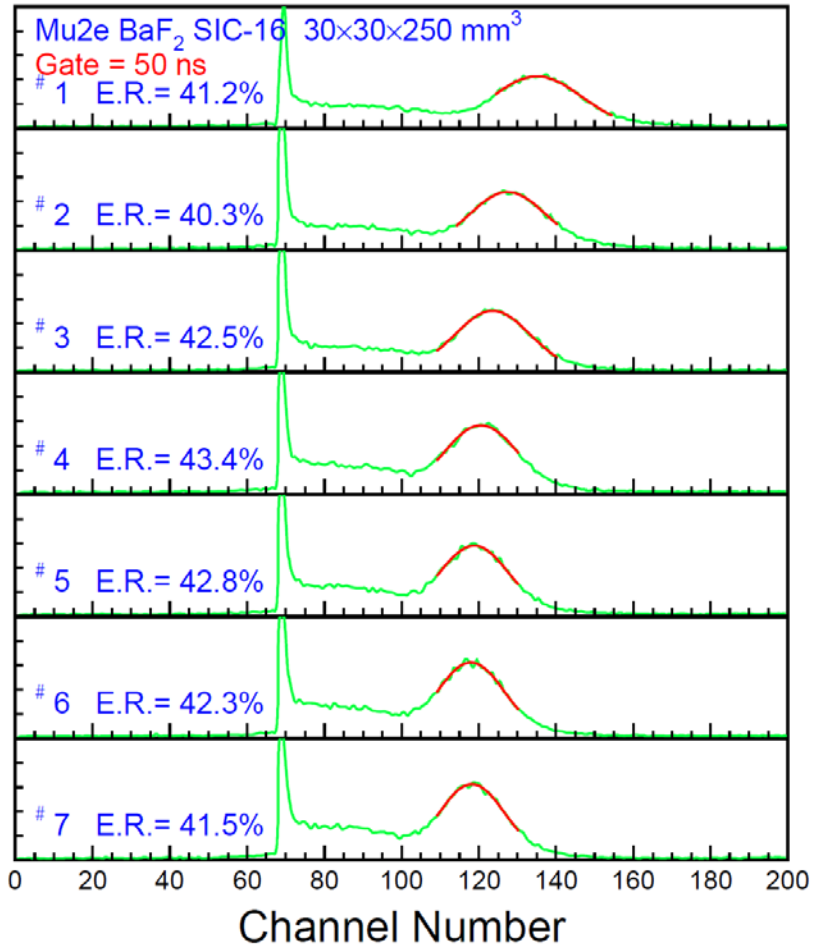

Average ER = 17.9%

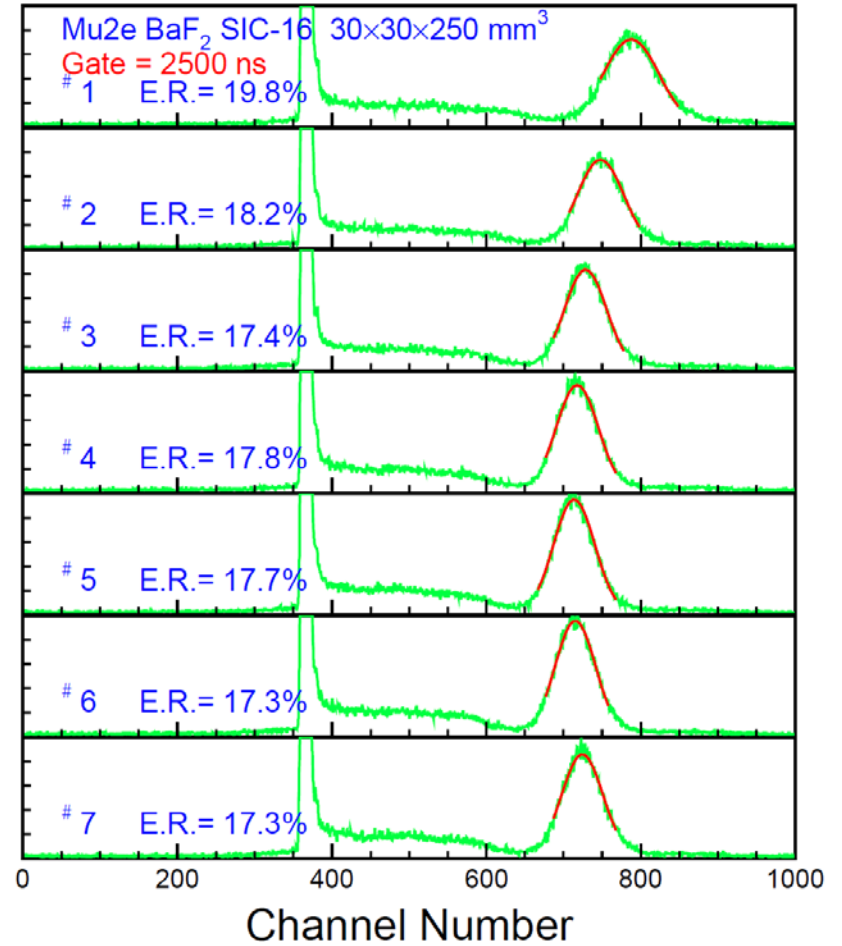

# PHS

Average ER = 41.6%

Average ER = 18.1%

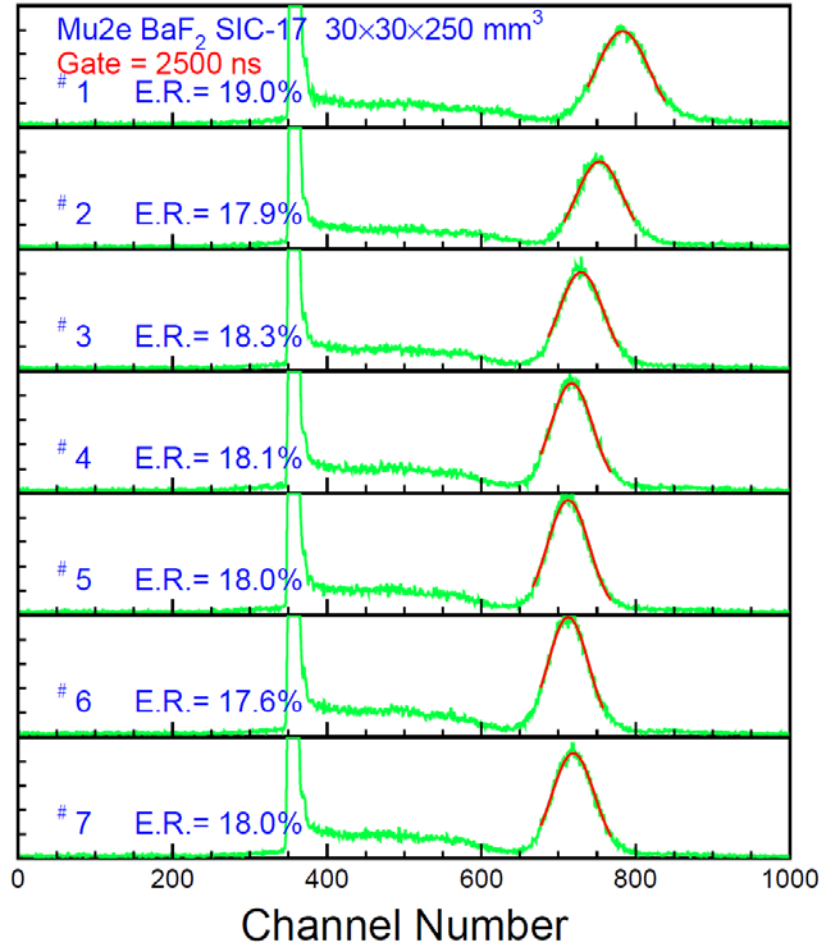
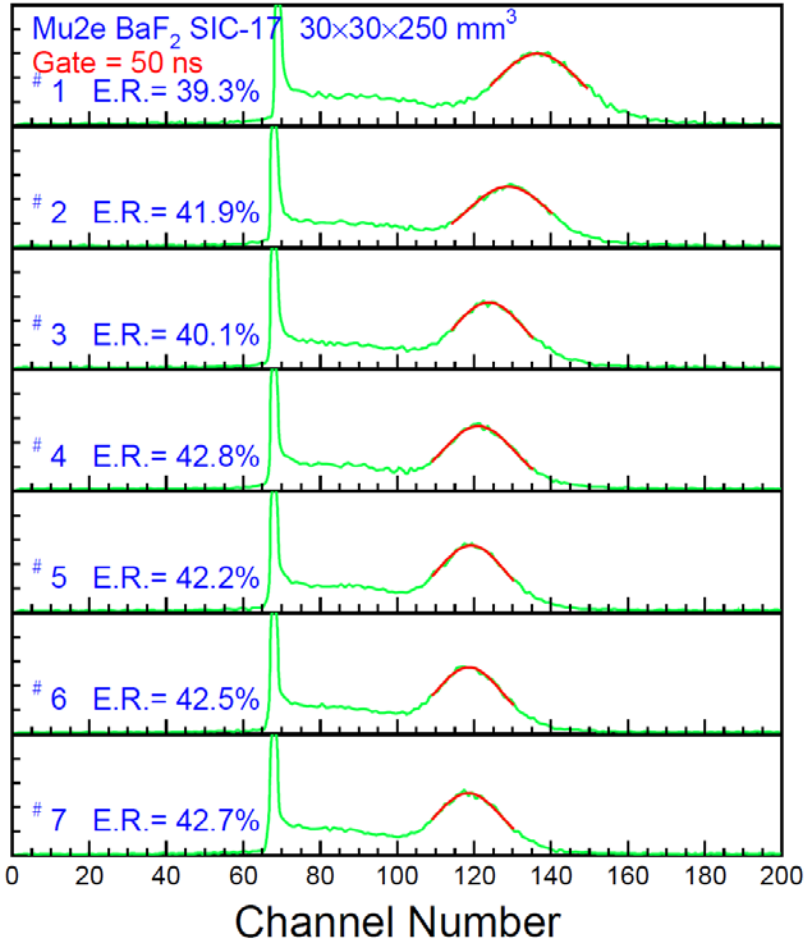

# PHS

Average ER = 42.6%

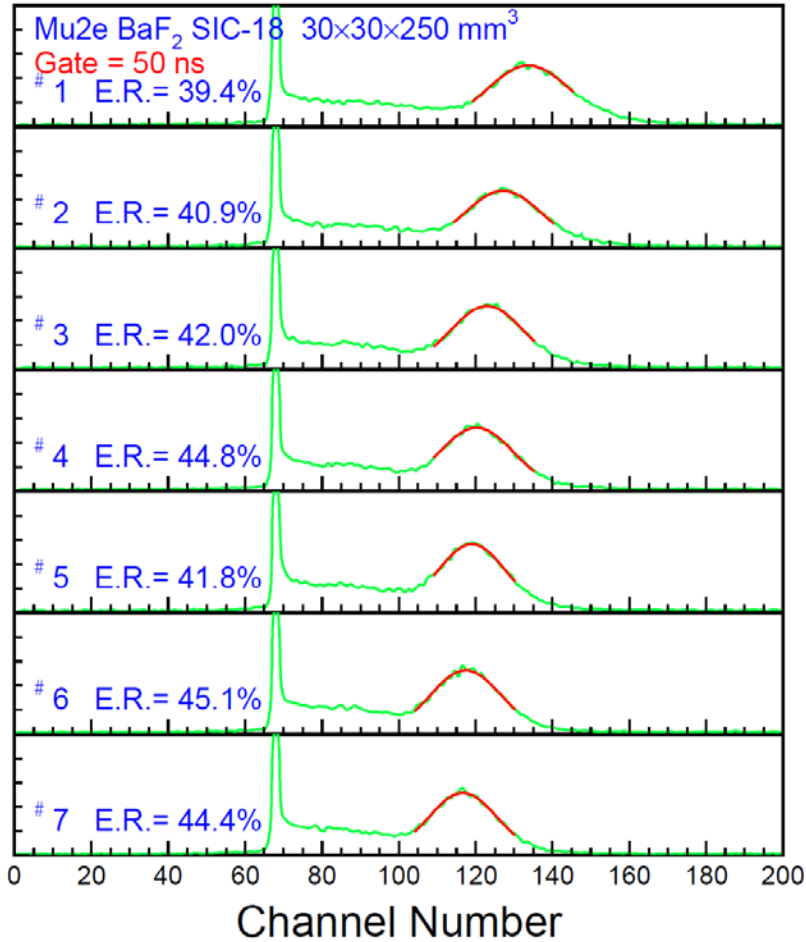

Average ER = 18.1%

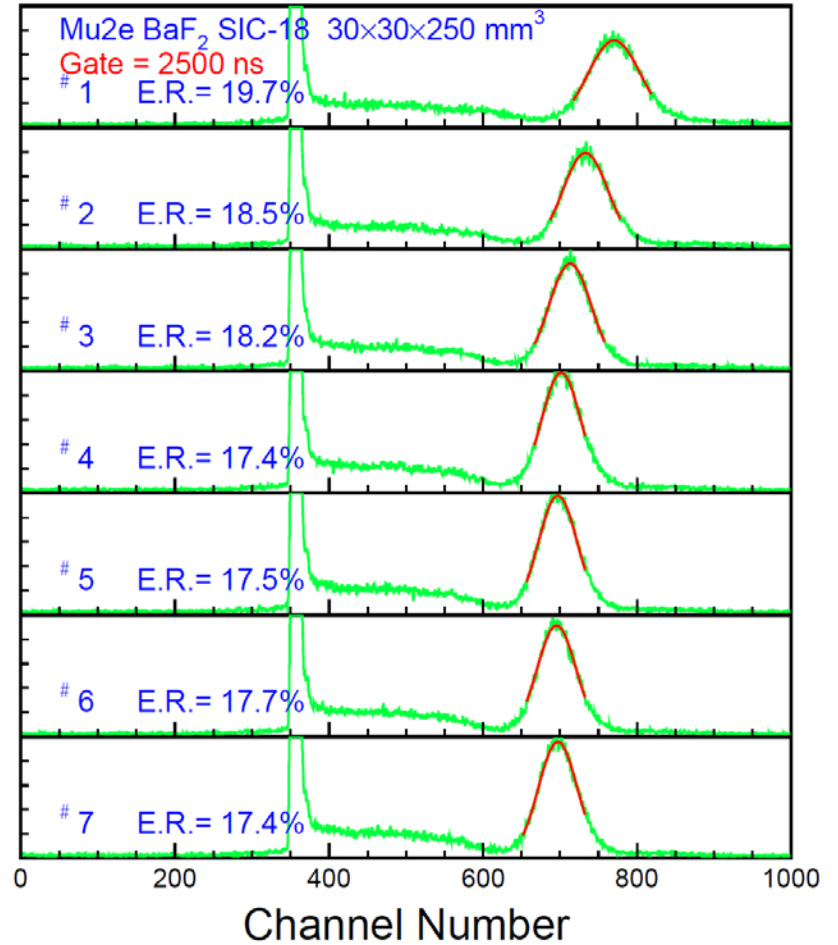



# PHS

Average ER = 43.6%

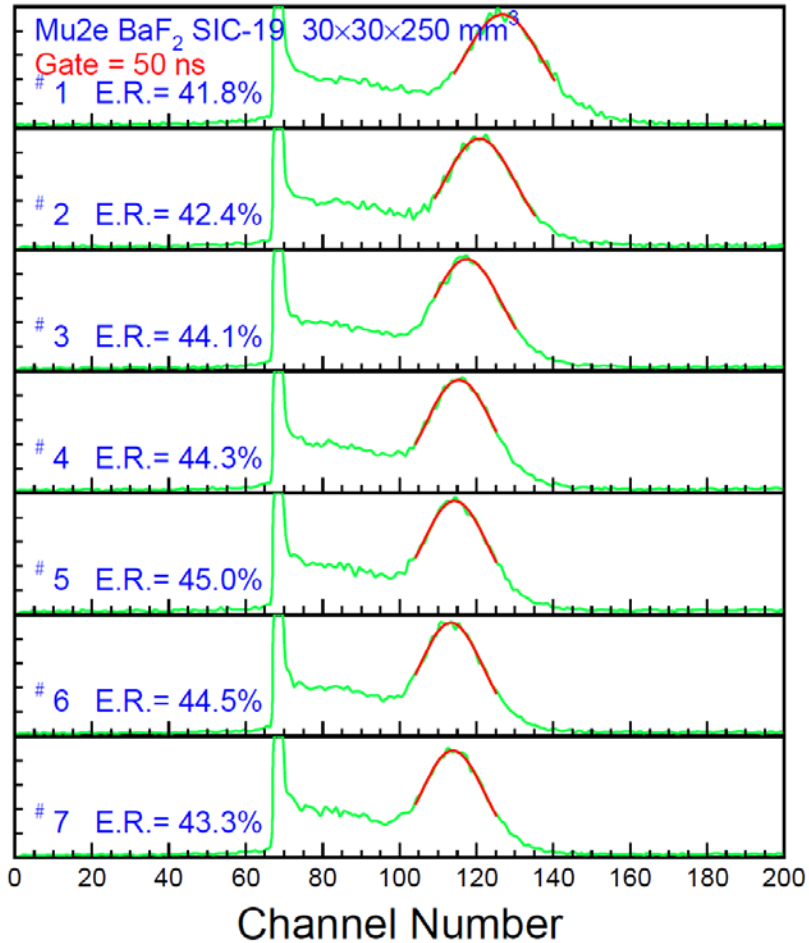

Average ER = 18.0%

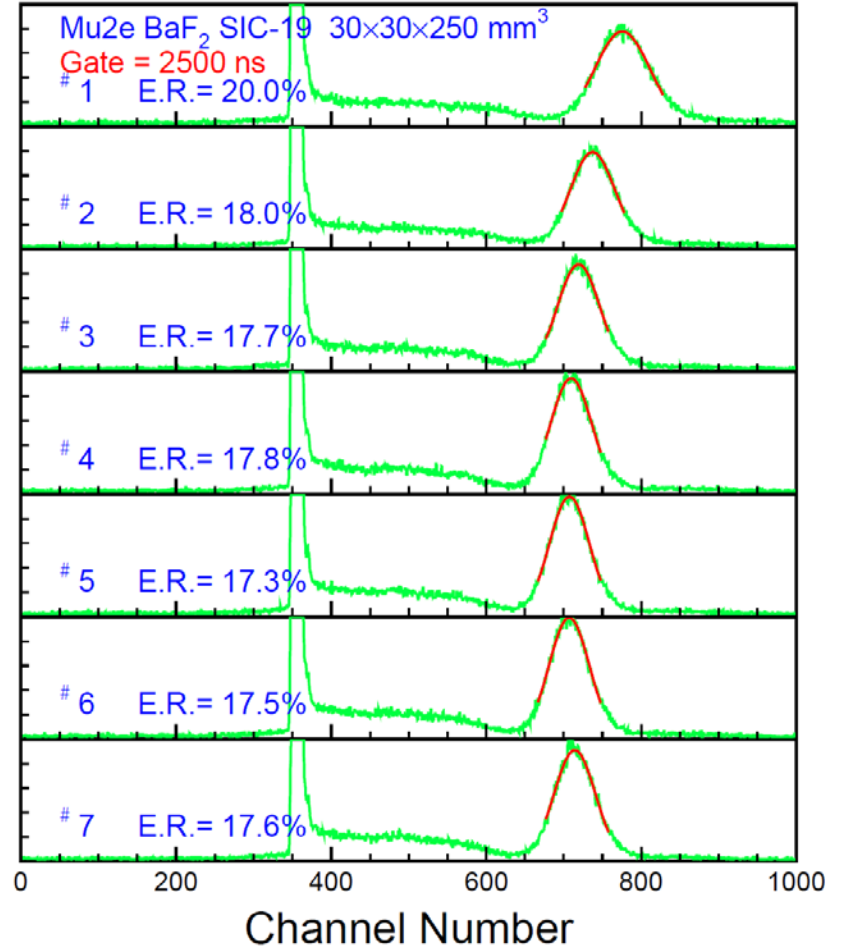

# PHS

Average ER = 41.4%

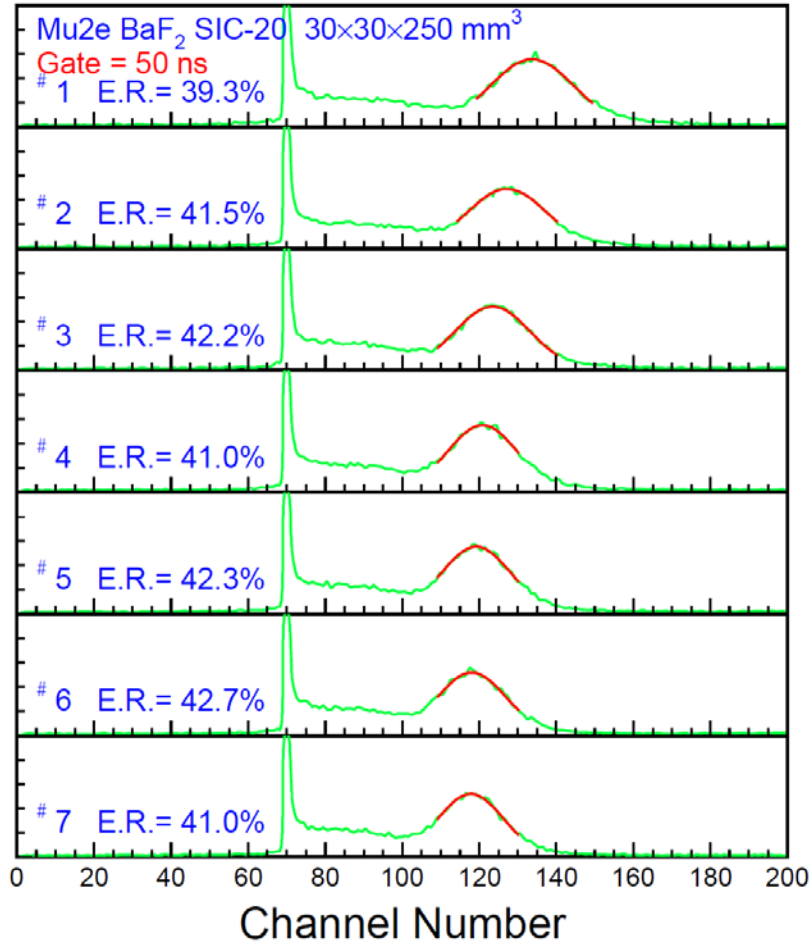

Average ER = 17.8%

