

Ph 76 ADVANCED PHYSICS LABORATORY

– ATOMIC AND OPTICAL PHYSICS –

Saturated Absorption Spectroscopy

I. BACKGROUND

One of the most important scientific applications of lasers is in the area of precision atomic and molecular spectroscopy. Spectroscopy is used not only to better understand the structure of atoms and molecules, but also to define standards in metrology. For example, the second is defined from atomic clocks using the 9192631770 Hz (exact, by definition) hyperfine transition frequency in atomic cesium, and the meter is (indirectly) defined from the wavelength of lasers locked to atomic reference lines. Furthermore, precision spectroscopy of atomic hydrogen and positronium is currently being pursued as a means of more accurately testing quantum electrodynamics (QED), which so far is in agreement with fundamental measurements to a high level of precision (theory and experiment agree to better than a part in 10^8). An excellent article describing precision spectroscopy of atomic hydrogen, the simplest atom, is attached (Hänsch *et al.* 1979). Although it is a bit old, the article contains many ideas and techniques in precision spectroscopy that continue to be used and refined to this day.

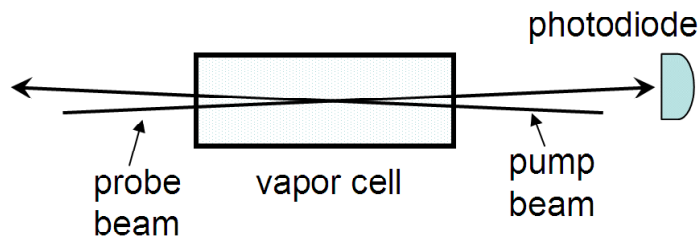

Figure 1. The basic saturated absorption spectroscopy set-up.

Qualitative Picture of Saturated Absorption Spectroscopy – 2-Level Atoms. Saturated absorption spectroscopy is one simple and frequently-used technique for measuring narrow-line atomic spectral features, limited only by the natural linewidth Γ of the transition (for the rubidium D lines $\Gamma \approx 6$ MHz), from an atomic vapor with large Doppler broadening of $\Delta\nu_{Dopp} \sim 1$ GHz. To see how saturated absorption spectroscopy works, consider the experimental set-up shown in Figure 1. Two lasers are sent through an atomic vapor cell from opposite directions; one, the “probe” beam, is very weak, while the other, the “pump” beam, is strong. Both beams are derived from the same laser, and therefore have the same frequency. As the laser frequency is scanned, the probe beam intensity is measured by a photodetector.

If one had 2-level atoms in the vapor cell, one might record spectra like those shown in Figure 2. The upper plot gives the probe beam absorption without the pump beam. Here one sees simple Doppler-

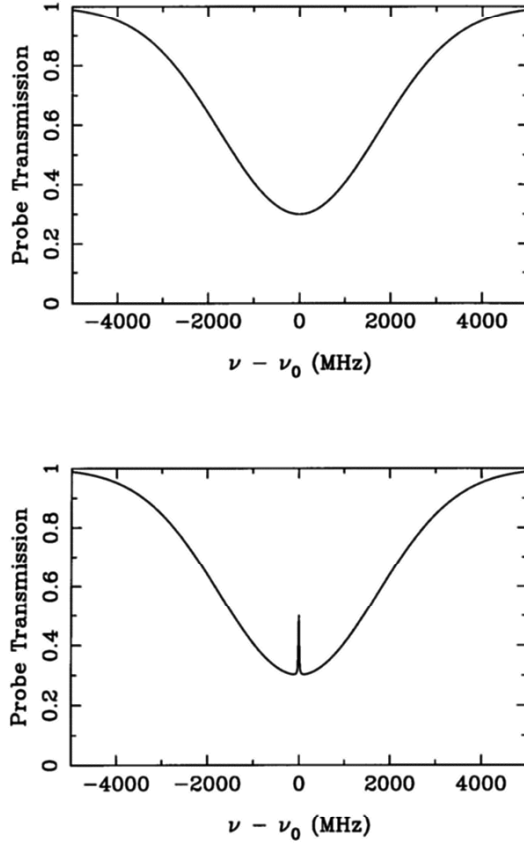

Figure 2. Probe absorption spectra for 2-level atoms, both without (upper) and with (lower) the pump beam.

broadened absorption; in our case the Doppler width is much larger than the natural linewidth, $\Delta\nu_{Dopp} \gg \Gamma$, and the optical depth of the vapor is fairly small $\tau(\nu) \lesssim 1$ (the transmitted fraction of the probe is $e^{-\tau(\nu)}$, which defines the optical depth; τ is proportional to the atomic vapor density and the path length), so the probe spectrum is essentially a simple Gaussian profile.

The lower plot in Figure 2 shows the spectrum with the pump beam, showing an additional spike right at the atomic resonance frequency. The reason this spike appears is as follows: If the laser frequency is $\nu_0 - \Delta\nu$, then the probe beam is absorbed only by atoms moving with longitudinal velocity $v \approx c\Delta\nu/\nu_0$, moving toward the probe beam. These atoms see the probe beam blueshifted into resonance; other atoms are not in resonance with the probe beam, and so they do not contribute to the probe absorption. These same atoms see the pump beam red-shifted further from resonance (since the pump beam is in the opposite direction) so they are unaffected by the pump beam. Thus for laser frequencies $\nu \neq \nu_0$, the probe absorption is the same with or without the pump beam. However if $\nu = \nu_0$, then atoms with $v = 0$ contribute to the probe absorption. These $v = 0$ atoms also see an on-resonance pump beam, which is strong enough to keep a significant fraction of the atoms in the excited state, where they do not absorb the probe beam (in fact they increase the probe beam intensity via stimulated emission). Thus at $\nu = \nu_0$ the probe absorption is *less* than it was without the pump beam. (If the pump beam had infinite intensity, half of the atoms would

be in the excited state at any given time, and there would be identically zero probe absorption. One would say these atoms were completely “saturated” by the pump beam, hence the name saturated absorption spectroscopy.) The advantage of this form of spectroscopy should be obvious . . . one can measure sharp Doppler-free features in a Doppler-broadened vapor.

Qualitative Picture of Saturated Absorption Spectroscopy – Multi-level Atoms. If the atoms in the absorption cell had a single ground state and two excited states (typically an electronic level split by the hyperfine interaction), and the separation of the excited states was less than the Doppler width, then one would see a spectrum like that shown in Figure 3. The peaks on the left and right are ordinary saturated absorption peaks at ν_1 and ν_2 , the two resonance frequencies. The middle peak at $(\nu_1 + \nu_2)/2$ is called a “cross-over resonance.” If you think about it for a while you can see where the extra peak comes from. It arises from atoms moving at velocities such that the pump is in resonance with one transition, and the probe is in resonance with the other transition. If you think about it a bit more you will see there are *two* velocity classes of atoms for which this is true – atoms moving toward the pump laser, and away from it.

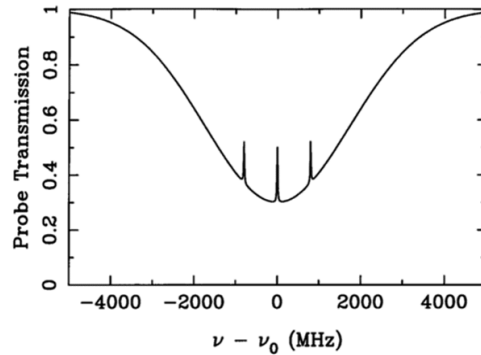

Figure 3. Saturated absorption spectrum for atoms with a single ground state and two closely spaced excited states.

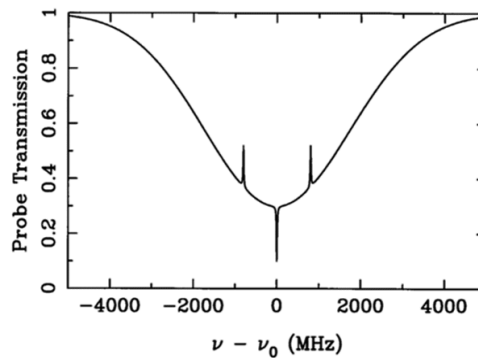

Figure 4. Saturated absorption spectrum for atoms with a single excited state that can decay into either of two closely spaced ground states.

If the atoms in the vapor cell had a single excited state but two hyperfine ground states (we call them both “ground” states because neither can decay via an allowed transition), and the separation of the ground states was less than the Doppler width, then one might see a spectrum like in Figure 4. The extra cross-over dip results from a phenomenon called “optical pumping,” which occurs because atoms in the excited state can decay into either of the two stable ground states. Thus if atoms are initially in ground state $g1$, and one shines in a laser that excites $g1 \rightarrow e$, atoms will get excited from $g1 \rightarrow e$ over and over again until they once spontaneously decay to $g2$, where they will stay. The state $g2$ is called a “dark state” in this case, because atoms in $g2$ are not affected by the laser. We see that a laser exciting $g1 \rightarrow e$ will eventually optically pump all the atoms into $g2$.

To see how optical pumping produces the extra crossover dip, remember that only the pump laser can optically pump – the probe laser is by definition too weak. Also remember the atoms in the cell are not in steady state. When they hit the walls they bounce off about equally distributed in both ground states, and the optical pumping only operates for a short period of time as the atoms travel through the laser beams. If you think about it a while you can see there are two velocity classes of atoms that are responsible for the dip. For one velocity class the pump laser excites $g1 \rightarrow e$, which tends to pump atoms into $g2$. Then the probe laser, which excites $g2 \rightarrow e$ for these atoms, sees extra absorption. For the other velocity class the pump laser excites $g2 \rightarrow e$, $g1$ gets overpopulated, and again the probe laser (which now excites $g1 \rightarrow e$ for these atoms) sees more absorption.

Quantitative Picture of Saturated Absorption Spectroscopy – 2-Level Atoms. One can fairly easily write down the basic ideas needed to calculate a crude saturated absorption spectrum for 2-level atoms, which demonstrates much of the underlying physics. The main features are: 1) the transmission of the probe laser beam through the cell is $e^{-\tau(\nu)}$, $\tau(\nu)$ is the optical depth of the vapor; 2) the contribution to $\tau(\nu)$ from one velocity class of atoms is given by

$$d\tau(\nu, v) \sim (P_1 - P_2)F(\nu, v)dn(v)$$

where P_1 is the relative population of the ground state, P_2 is the relative population of the excited state ($P_1 + P_2 = 1$),

$$dn \sim e^{-mv^2/2kT} dv$$

is the Boltzmann distribution (for v along the beam axis), and

$$F(\nu, v) = \frac{\Gamma/2\pi}{(\nu - \nu_0 + \nu_0 v/c)^2 + \Gamma^2/4}$$

is the normalized Lorentzian absorption profile of an atom with natural linewidth Γ , including the Doppler shift. Putting this together, we have the differential contribution to the optical depth, for laser frequency ν and atomic velocity v :

$$d\tau(\nu, v) = \tau_0 \frac{\nu_0}{c} (P_1 - P_2) F(\nu, v) e^{-mv^2/2kT} dv.$$

The overall normalization comes in with the τ_0 factor, which is the optical depth at the center of resonance line, *i. e.* $\tau_0 = \int d\tau(\nu_0, v)$ with no pump laser (the integral is over all velocity classes). 3) The populations of the excited and ground states are given by $P_1 - P_2 = 1 - 2P_2$, and

$$P_2 = \frac{s/2}{1 + s + 4\delta^2/\Gamma^2}$$

where $s = I/I_{sat}$ and $\delta = \nu - \nu_0 - \nu_0 v/c$. I_{sat} is called the saturation intensity (for obvious reasons ... if you consider the above formula for P_2 with $\delta = 0$, P_2 “saturates” $P_2 \rightarrow 1/2$ as $I/I_{sat} \rightarrow \infty$). The value of

I_{sat} is given by

$$I_{sat} = 2\pi^2 hc\Gamma/3\lambda^3.$$

For the case of rubidium, $\Gamma \approx 6$ MHz, giving $I_{sat} \approx 2$ mW/cm².

The underlying physics in points (1) and (2) should be recognizable to you. Point (3) results from the competition between spontaneous and stimulated emission. To see roughly how this comes about, write the population rate equations as

$$\begin{aligned}\dot{P}_1 &= \Gamma P_2 - \alpha I(P_1 - P_2) \\ \dot{P}_2 &= -\Gamma P_2 + \alpha I(P_1 - P_2)\end{aligned}$$

where the first term is from spontaneous emission, with Γ equal to the excited state lifetime, and the second term is from stimulated emission, with α a normalization constant. Note that the stimulated emission is proportional to the intensity I . In the steady-state $\dot{P}_1 = \dot{P}_2 = 0$, giving

$$P_2 = \frac{\alpha I/\Gamma}{1 + 2\alpha I/\Gamma}$$

The term $\alpha I/\Gamma$ corresponds to the $s/2$ term above (note I_{sat} is proportional to Γ). A more complete derivation of the result, with all the normalization constants, is given in Milonni and Eberly (1988), and in Cohen-Tannoudji *et al.* (1992), but this gives you the basic idea.

Assuming a fixed vapor temperature, atomic mass, etc., the saturated absorption spectrum is determined by two adjustable external parameters, the pump intensity I_{pump} and the on-resonance optical depth τ_0 . The latter is proportional to the vapor density inside the cell. Figure 5 shows calculated spectra at fixed laser intensity for different optical depths, and Figure 6 shows spectra at fixed optical depth for different laser intensities.

In Figure 5 one sees mainly what happens when the vapor density is increased in the cell. At low densities the probe absorption is slight, with a Gaussian profile, and the absorption increases as the vapor density increases. At very high vapor densities the absorption profile gets deeper and broader. It gets broader simply because the absorption is so high near resonance that the probe is almost completely absorbed; for greater vapor densities the probe gets nearly completely absorbed even at frequencies fairly far from resonance; thus the width of the absorption profile appears broader. The saturated-absorption feature in Figure 5 does pretty much what you would expect. The probe absorption is reduced on resonance, due to the action of the pump laser. At very high vapor densities the saturated-absorption feature becomes smaller. This is because while the pump laser reduces the absorption, it doesn't eliminate it; thus at high vapor densities the probe is nearly completely absorbed even with the pump laser. The moral of this story is that the vapor density shouldn't be too low or high if you want to see some saturated-absorption features.

In Figure 6 one sees that if the pump intensity is low, the saturated-absorption feature is small, as one would expect. For larger pump intensities the feature grows in height and width. The width increases because at high laser intensities the effect of the pump laser saturates on resonance, and continues to grow off resonance; thus the width of the feature increases, an effect known as "power broadening."

Finally, it should be noted that calculating the saturated absorption spectrum for real atoms, which must include optical pumping, many different atomic levels, atomic motion in the vapor cell, and the polarization of the laser beams, is considerably more subtle. A recent paper by Schmidt *et al.* (1994) shows much detailed data and calculations for the case of cesium.

Problem 1. Show that $\tau_0 = \int d\tau(\nu_0, \nu)$ when the pump laser intensity is zero, from the formula above.

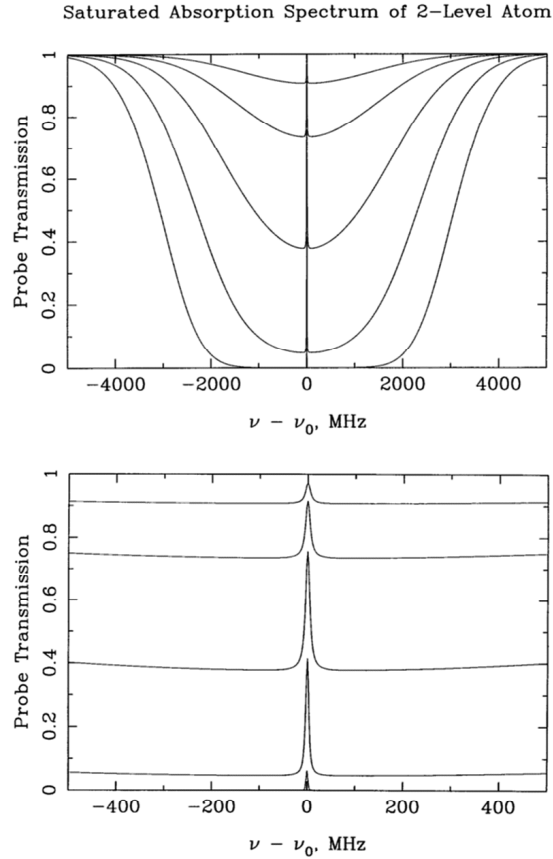

Figure 5. Calculated saturated-absorption spectra for two-level atoms, for $(\tau, I/I_{sat}) = (0.1, 10), (0.316, 10), (1, 10), (3.16, 10),$ and $(10, 10)$. The two plots show the same spectra with the frequency axis at different scales. Note the overall Doppler-broadened absorption, with the small saturated-absorption feature at line center.

Hint: the integral is simplified by noting that $\Gamma \ll \Delta\nu_{Dopp}$.

Problem 2. The above calculations all assume that the pump laser has the same intensity from one end of the cell to another. This is okay for a first approximation, but calculating what really happens is an interesting problem. Consider a simple laser beam (the pump) shining through a vapor cell. If the laser intensity is weak, and the atoms are all pretty much in the ground state, then the laser intensity changes according to the equation $dI/dx = -\alpha I$, where $\alpha = \alpha(\nu)$ depends on the laser frequency, but not on position inside the cell (α^{-1} is called the absorption length in this case). This equation has the solution $I(x) = I_{init}e^{-\alpha x}$, where I_{init} is the initial laser intensity. The transmission through the cell, $e^{-\alpha L}$, where L is the length of the cell, is what we called $e^{-\tau}$ above.

Your job in this problem is to work out what happens when the input laser beam is not weak, and thus we cannot assume that the atoms are all in the ground state. In this case $\alpha = \alpha(\nu, x)$, which makes the differential equation somewhat more interesting. Assume the laser is on resonance for simplicity. Then the attenuation coefficient at any position x is proportional to $P_1 - P_2$, which in turn is proportional to

Saturated Absorption Spectrum of 2-Level Atom

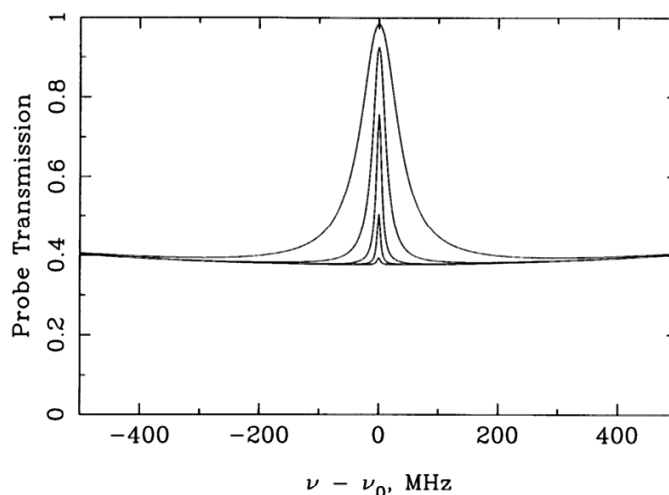

Figure 6. Calculated saturated-absorption spectra for two-level atoms, for $(\tau, I/I_{sat}) = (1, 0.1), (1, 1), (1, 10), (1, 100),$ and $(1, 1000)$. Note at large laser intensities the saturated absorption feature is “power broadened” as the line saturates.

$1/(1 + s)$. Thus we have $\alpha(\nu_0, x) = \alpha_0/(1 + s(x))$. In the weak beam limit $I \ll I_{sat}$ this reduces to our previous expression, so $\alpha_0 = \tau_0/L$. Write down an expression which relates the saturation parameter of the laser as it exits the cell s_{final} , the saturation parameter at the cell entrance $s_{initial}$, and the weak-limit optical depth τ_0 . Check your expression by noting in the limit of finite τ_0 and small s you get $s_{final} = s_{initial}e^{-\tau_0}$. If $\tau_0 = 100$, how large must $s_{initial}$ be in order to have a transmission of $1/2$ (*i. e.* $s_{final} = s_{initial}/2$)?

Atomic Structure of Rubidium. The ground-state electronic configuration of rubidium consists of closed shells plus a single 5s valence electron. This gives a spectrum which is similar to hydrogen (see attached Scientific American article). For the first excited state the 5s electron is moved up to 5p. Rubidium has two stable isotopes: ^{85}Rb (72 percent abundance), with nuclear spin quantum number $I = 5/2$, and ^{87}Rb (28 percent abundance), with $I = 3/2$.

The different energy levels are labeled by “term states”, with the notation $^{2S+1}L'_J$, where S is the spin quantum number, L' is the spectroscopic notation for the angular momentum quantum number (*i. e.* S, P, D, ..., for orbital angular momentum quantum number $L = 0, 1, 2, \dots$), and $J = L + S$ is the total angular momentum quantum number. For the ground state of rubidium $S = 1/2$ (since only a single electron contributes), and $L = 0$, giving $J = 1/2$ and the ground state $^2S_{1/2}$. For the first excited state we have $S = 1/2$, and $L = 1$, giving $J = 1/2$ or $J = 3/2$, so there are two excited states $^2P_{1/2}$ and $^2P_{3/2}$. Spin-orbit coupling lifts splits the otherwise degenerate $P_{1/2}$ and $P_{3/2}$ levels. (See any good quantum mechanics or atomic physics text for a discussion of spin-orbit coupling.)

The dominant term in the interaction between the nuclear spin and the electron gives rise to the magnetic hyperfine splitting (this is described in many quantum mechanics textbooks). The form of the interaction

term in the atomic Hamiltonian is $H_{hyp} \propto J \cdot I$, which results in an energy splitting

$$\Delta E = \frac{C}{2} [F(F+1) - I(I+1) - J(J+1)]$$

where $F = I + J$ is the total angular momentum quantum number including nuclear spin, and C is the “hyperfine structure constant.” Figures 7 and 8 shows the lower S and P energy levels for ^{85}Rb and ^{87}Rb , including the hyperfine splitting.

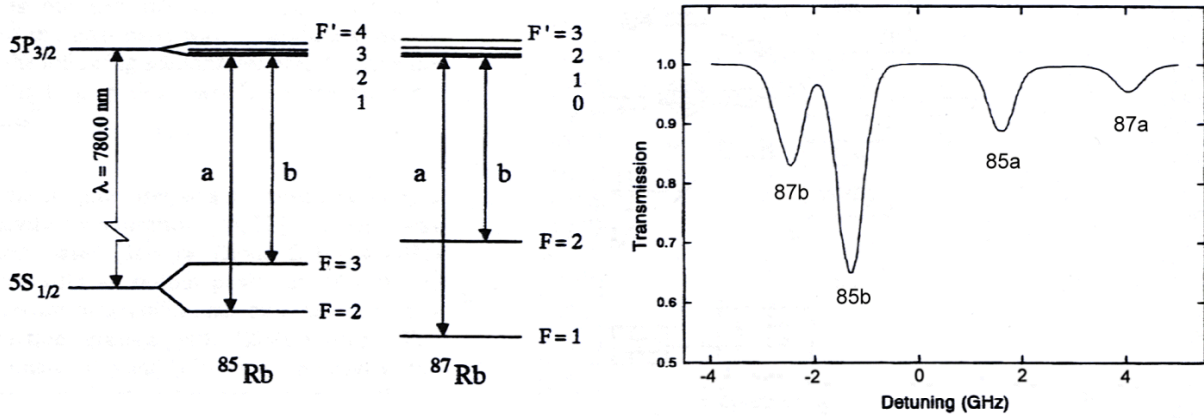

Figure 7. (Left) Level diagrams for the D2 lines of the two stable rubidium isotopes. (Right) Typical absorption spectrum for a rubidium vapor cell, with the different lines shown.

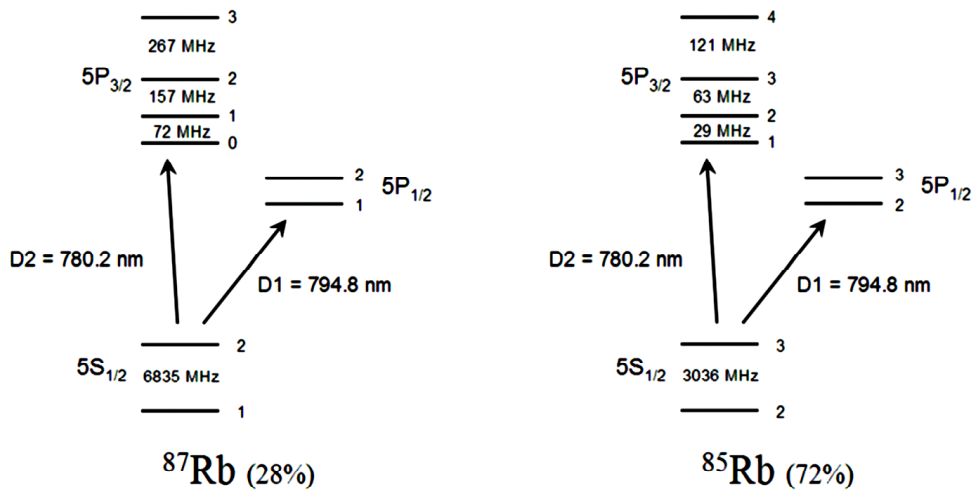

Figure 8. More rubidium level diagrams, showing the hyperfine splittings of the ground and excited states.

II. LABORATORY EXERCISES.

The goal of this section is first to observe and record saturated absorption spectra for as many of the

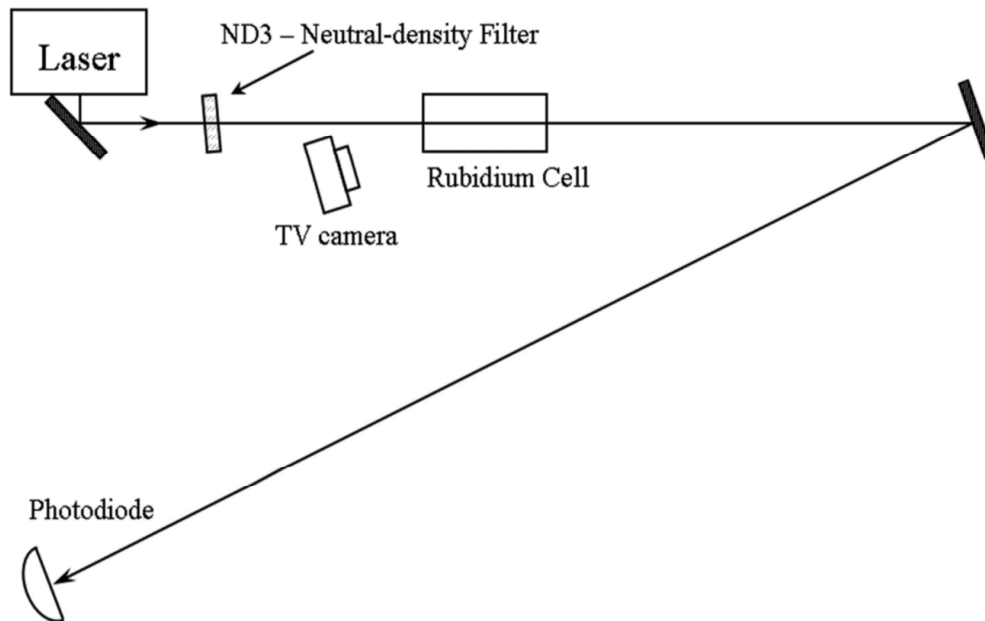

Figure 9. Recommended set-up to get the laser running on the rubidium resonance lines.

rubidium lines as you can, and then to see how well you can measure the $P_{3/2}$ hyperfine splitting of ^{87}Rb using a auxiliary interferometer as a length standard.

Remember that eye safety is important. First of all the laser operates at 780 nm, which is very close to being invisible. Thus you can shine a beam into your eye without noticing it. Also, the laser power is about 20 milliwatts, and all that power is concentrated in a narrow beam. Looking directly at the Sun puts about 1 milliwatt into your eye, and that much power is obviously painful. It is certainly possible to cause permanent eye damage using the Ph76 laser if you are not careful. Therefore – be careful. ALWAYS WEAR LASER GOGGLES WHEN THE LASER IS ON! As long as you keep the goggles on, your eyes will be protected.

Week 1 – Getting the Laser On Resonance.

The first step is to get the laser turned on and tuned to hit the rubidium lines. We see in Figure 7 that the lines span about 8 GHz, which can be compared with the laser frequency of $\nu = c/\lambda = 4 \times 10^{14}$ Hz. Thus to excite the atoms at all the laser frequency must be tuned to about a part in 10^5 . Start with the simple set-up shown in Figure 8. The ND filter can be removed when aligning the laser beam.

Once you have the beam going about where you want it, sweep the high-voltage going to the grating PZT with a triangle wave, so that the voltage varies from about 0 to 100 volts. Use the HV/100 to monitor the high voltage on the oscilloscope. Sweeping this voltage sweeps the grating position using a small piezo-electric actuator (made from lead zirconate titanate, hence PZT). While the high voltage is scanning you should then also change the laser injection current up and down by hand. The current makes large changes in the laser frequency, while the PZT makes small changes (see the laser primer for details).

The plan is that with all this sweeping the laser will sweep over the rubidium lines and you will see some fluorescence inside the vapor cell. This will appear as a bright line inside the cell; don't be confused

by scattering off the windows of the cell. If you cannot see the atoms flashing at all, ask your TA for help. The laser may need some realignment, or you may just not be doing something right.

Once you see fluorescence, compare the photodiode output to the rubidium spectrum shown in Figure 7. Usually you can only get the laser to scan over part of this spectrum without mode hopping (see the laser primer). Record your best spectrum using the digital oscilloscope and print it out. At this point the laser is tuned to the rubidium lines. Before proceeding with the rest of the experiment, move the ND filter from its location in Figure 9 to a new position right in front of the photodiode. If you look closely you'll see the absorption lines are still there, but much weaker. How come? There are two reasons. First, optical pumping is faster with more laser power, so the atoms are more quickly pumped to the dark state. That makes the absorption less. Second, the atoms become saturated with the high power, just like you calculated above. That also reduces the absorption.

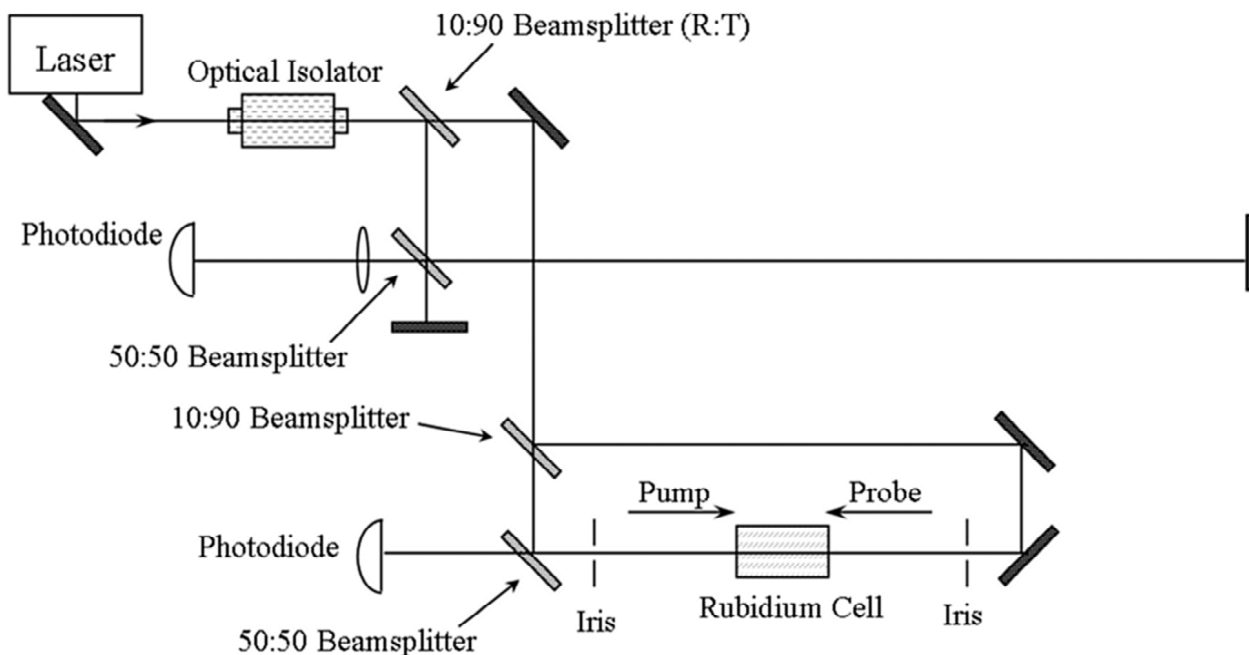

Figure 10. Recommended set-up to record rubidium saturated absorption spectra, and for measuring the hyperfine splittings.

Week 1 – Getting a Saturated Absorption Spectrum.

The suggested set-up for observing saturated absorption spectra is shown in Figure 10. Since the laser is on resonance from the last section, leave it alone while you change the set-up. Ignore the interferometer part for now; that comes in after you've gotten some spectra. The optical isolator is a device that contains a two polarizers, a special crystal, and strong permanent magnets (see Appendix I). The first polarizer is aligned with the polarization of the input laser (vertical), and simply transmits the beam. The crystal in the magnetic field rotates the polarization of the beam by about 45 degrees, using the Faraday effect, and the beam exits through the second polarizer, which is set at 45 degrees. A beam coming back toward the

laser sees all this in reverse; the beam polarization gets rotated in the crystal, so that the polarization is 90 degrees with respect to the vertical polarizer, and the beam is not transmitted. These devices are also sometimes called optical diodes, since light only passes through them in one direction. We use an optical isolator here to keep stray light (generated downstream...note the pump beam goes backward after it passes through the cell) from getting back to the diode laser, where it can adversely affect the frequency stability.

Note the 10:90 beamsplitter puts most of the laser power into the probe beam. The irises are an alignment guide; if you have both the pump and probe beams going through small irises, then you can be assured that the beams overlap in the rubidium cell. If you block the pump beam you should get a spectrum that looks pretty much the same as you had in the previous section.

Lab Exercise 1. Observe and record the best spectra you can for whatever rubidium lines you can see, especially the two strongest lines (87b and 85b in Figure 7). Get some nice spectra and put hard copies into your notebook. Note (but don't bother recording) that the saturated absorption features go away if you block the pump beam, as expected.

Week 2 – Measuring the Hyperfine Splitting.

Now finish the set-up in Figure 10 by adding the interferometer. (Turn off the laser frequency scanning while setting up the interferometer, so the fringes are stable.) Make the arm difference as long as you can. If you want you can add another mirror to the long arm to bounce it across the table. The longer the long arm, the better your measurement will be. Recombine the beams on the beamsplitter and send one of the output beams through a strong lens, so that the beam is expanded quite a bit. Align the overlap of the beams (in position as well as angle) until you see nice fringes on the expanded beam. Align the overlap so the fringes spacing is very large. Place the photodiode such that it only intercepts the light from one fringe of the interferometer.

If you now scan the laser frequency you should observe temporal fringes on the photodiode output. The fringe spacing can be computed from the arm length difference, which you should measure. When a beam travels a distance L it picks up a phase $\varphi = 2\pi L/\lambda$, so the electric field becomes

$$E = E_0 e^{i\omega t} e^{i\varphi}$$

When the beam is split in the interferometer, the two parts send down the two arms, and then recombined, the electric field is

$$\begin{aligned} E &= E_{arm1} + E_{arm2} \\ &= E_0 e^{i\omega t} \left[e^{i4\pi L_1/\lambda} + e^{i4\pi L_2/\lambda} \right] \end{aligned}$$

where L_1 and L_2 are the two arm lengths. The additional factor of two comes from the fact that the beam goes down the arm and back again. Squaring this to get the intensity we have

$$\begin{aligned} I &\sim \left| e^{i4\pi L_1/\lambda} + e^{i4\pi L_2/\lambda} \right|^2 \\ &\sim 1 + \cos\left(\frac{4\pi\Delta L}{\lambda}\right) \end{aligned}$$

where $\Delta L = L_1 - L_2$. If the laser frequency is constant, then the fringe pattern goes through one cycle every time the arm length changes by $\lambda/2$.

Problem 3. If ΔL is fixed, how much does the laser frequency have to change to send I through one brightness cycle? For your known ΔL , what is the fringe period in MHz? From this you can convert your

measurement of ΔL into a calibration of the laser frequency scan.

Use the two oscilloscope traces to plot the interferometer fringes and the saturated absorption spectra at the same time, as you scan the laser frequency. Watch that the interferometer fringes are uniform as a function of PZT voltage; if not the nonlinearities could compromise your calibration. Zoom in on the hyperfine features you want to measure. You will need to know which features belong to which lines, so identify the features by comparing your spectra with the level diagrams in Figures 7 and 8. Print out some good spectra, measure the spacings of the various features using a ruler, and you can turn this all into a direct measurement of the hyperfine splittings. Try to do this for both lines 87b and 85b in Figure 7. Note there are no tricks or complicated math in any of this. You just have to understand what's going on, and not lose any factors of two. No fair adjusting the answer by factors of two until it agrees with the known splittings.

Lab Exercise 2. Measure and record the largest $P_{3/2}$ hyperfine splittings for ^{85}Rb and ^{87}Rb , in MHz. Estimate the accuracy of your measurement, knowing the various uncertainties you encountered along the way.

III. REFERENCES.

- Cohen-Tannoudji, C., Dupont-Roc, J., and Grynberg, G. 1992, *Atom-Photon Interactions*, (Wiley).
- Hänsch, T. W., Schawlow, A. L., and Series, G. W. 1979, "The Spectrum of Atomic Hydrogen," *Scientific American* **240**, 94 (March).
- Milonni, P., and Eberly, J. 1988, *Lasers*, (Wiley).
- Schmidt, O., Knaak, K.-M., Wynands, R., and Meschede, D. 1994, "Cesium Saturation Spectroscopy Revisited: How to Reverse Peaks and Observe Narrow Resonances," *Appl. Phys. B*, **59**, 167.

Appendix I – The Optical Isolator

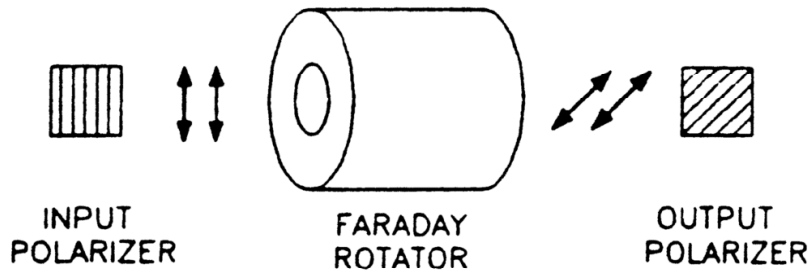

Figure 11. Schematic picture of an optical isolator. Not shown is the large longitudinal magnetic field in the Faraday rotator produced by strong permanent magnets inside the device.

The optical isolator is a somewhat subtle device, which uses the Faraday effect. The Faraday effect is a rotation of the plane of polarization of a light beam in the presence of a strong magnetic field along the propagation axis. You can get a feel for this effect by considering a simple classical picture. An incoming light beam imposes an oscillating electric field on the electrons in the solid, which causes the electrons to oscillate. Normally the oscillating electrons re-radiate the light in the same direction as the original beam, which doesn't change the polarization of the light (it does change the phase, however, which is the cause of the material index of refraction). With the application of a strong longitudinal magnetic field, you can see that the Lorentz force $e \vec{v} \times \vec{B}$ will shift the motion of the electrons, and rotate their plane of oscillation. As the electrons re-radiate this tends to rotate the polarization of the light beam. Obviously a hand-wavy argument, but it gives you the right idea.

The optical isolator uses the Faraday effect to rotate the polarization angle of the input beam by 45 degrees, and the output beam exits through a 45-degree polarizer (see Figure 12). Note that the diode laser's beam is polarized, in our case along the vertical axis. If one reflects the beam back into the optical isolator, the polarization experiences another 45-degree rotation, in the same direction as the first, and the beam is then extinguished by the input polarizer. You can see that the rotations have the correct sense using the classical picture. Thus the overall effect is that of an "optical diode" – light can go through in one direction, but not in the reverse direction.

The Faraday effect is typically very weak, so the optical isolator uses a special crystal, which exhibits an anomalously large Faraday effect, and a very strong longitudinal magnetic field produced by state-of-the-art permanent magnets. Optical isolators have gotten much smaller over the last couple of decades as magnet technology has improved. The magnetic field is strong only near the axis of the device, which therefore has a small clear aperture. Also, too much light intensity will burn a spot in the Faraday crystal, so one must be careful not to focus the diode laser to a tight spot inside the optical isolator.

The Spectrum of Atomic Hydrogen

For almost a century light emitted by the simplest of atoms has been the chief experimental basis for theories of the structure of matter. Exploration of the hydrogen spectrum continues, now aided by lasers

by Theodor W. Hänsch, Arthur L. Schawlow and George W. Series

The spectrum of the hydrogen atom has proved to be the Rosetta stone of modern physics: once this pattern of lines had been deciphered much else could also be understood. Most notably, it was largely the effort to explain the spectrum of light emitted by the hydrogen atom that inspired the laws of quantum mechanics. Those laws have since been found to apply not only to the hydrogen atom but also to other atoms, to molecules and to matter in bulk. They are the ultimate foundation of modern chemistry, of solid-state physics and even of applied sciences such as electronics.

The central position of the hydrogen atom in the history of 20th-century physics might seem to suggest that the spectrum has long been known in all its details. That is not so. Only in the past few years have some of the subtler features of the spectrum been resolved, and many others have not yet been observed directly. Measuring the positions of the spectral lines remains today a significant test of the predictions of the quantum theory.

The most recent advances in the analysis of the spectrum can be attributed to a new tool of spectroscopy: the laser. Because the finest details of the spectrum are closely spaced they can be distinguished only by light that is highly monochromatic, or confined to a narrow range of wavelengths. The laser is a source of such light. As a result of some ingenious laboratory technology it has become a spectroscopic instrument of unprecedented resolution.

The Line Spectrum

When light from a hot filament is dispersed according to wavelength by a prism or a diffraction grating, the result is a continuous fan of colors, but the spectrum from a pure, rarefied gas of atoms or molecules consists of discrete lines. If the spectrum is recorded from light emitted by the gas, it appears as a sequence of bright lines against a dark background. If light is passed through the gas, discrete wavelengths are ab-

sorbed, giving rise to dark lines on a bright background.

Hydrogen is the simplest of atoms, being made up of a single electron and a nucleus that consists of a single proton, and so it can be expected to have the simplest spectrum. The spectrum is not, however, an easy one to record. The most prominent line was detected in 1853 by Anders Jonas Ångström. (The common unit for measuring wavelengths of light is named for Ångström; one angstrom unit is equal to 10^{-9} centimeter.) In the next two decades three more lines were observed, but the first extended series of atomic-hydrogen lines was found not in the laboratory but in the spectra of stars. In 1881, working with the first photographs of stellar spectra, Sir William Huggins identified 10 lines as being emissions of atomic hydrogen.

It may seem surprising that lines of the hydrogen spectrum were seen in astronomical observations before they were seen in terrestrial experiments. The difficulty in measuring the spectrum in the laboratory is not in detecting the lines but in preparing pure atomic hydrogen. Ordinary hydrogen gas consists of diatomic molecules (H_2), which have a spectrum that is much more complicated than the spectrum of the isolated hydrogen atom. Splitting the molecules requires more energy than can be supplied by most thermal excitations, such as a flame. One device that furnishes the energy very effectively is the gas-discharge tube, where electrons accelerated by an applied voltage dissociate the molecules. Over the years means have been discovered for enhancing the atomic spectrum and suppressing the molecular one.

The spectral lines detected by Huggins range in wavelength from the red portion of the visible spectrum to the near ultraviolet. The first two lines are quite far apart, but the subsequent ones come at smoothly decreasing intervals, and those at the shortest wavelengths are bunched closely together. In 1885, working from the astronomical measurements, Johann Jakob Balmer found

that he could account for the positions of all the known lines by applying a simple empirical formula. The entire set of lines has since come to be known as the Balmer series. Another group of lines, the Lyman series, lies in the far ultraviolet, and there are other series at longer wavelengths. Within each series the individual lines are designated by Greek letters, starting with the line of longest wavelength. Thus the bright red line first seen by Ångström is the Balmer-alpha line, the next is the Balmer-beta line and so on. Because of the prominence of the Balmer-alpha line it is sometimes called

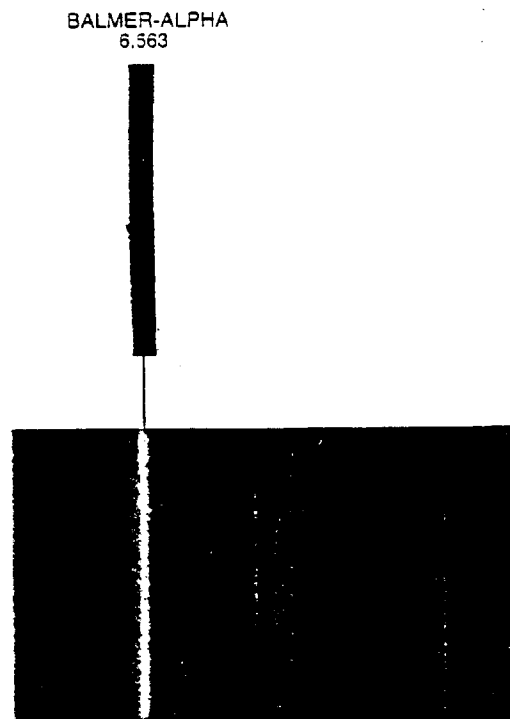

PATTERN OF DISTINCT LINES is formed when the light emitted by hydrogen atoms is dispersed according to wavelength. The lines are those of the Balmer series, and their approximate wavelengths are given in angstrom units (one angstrom is equal to 10^{-9} centimeter). The color photograph was made by Jon Brenneis and one of the authors (Schawlow)

simply the hydrogen-alpha, or H-alpha, line.

In 1889 Johannes Rydberg discovered that the line spectra of many elements, most notably those of the alkali metals, could be fitted by a single empirical formula. A later version of the formula, which is equivalent to Rydberg's equation but more explicit, has the form

$$\frac{1}{\lambda} = R \left[\frac{1}{(m+b)^2} - \frac{1}{(n+c)^2} \right]$$

Here λ (the Greek letter lambda) is the wavelength of a particular line in an atomic spectrum, m and n are numbers that take on successive integer values (1, 2, 3 and so on) and R , b and c are constants. The values of b and c depend on what series of lines is being measured, but R is the same for all lines of all the elements. R is now called the Rydberg constant: if the wavelength is expressed in meters, R has the value 1.097×10^7 and the dimensions of reciprocal meters. After Rydberg had checked his formula against a number of spectra he wrote: "I had just finished testing various forms of the function when I heard of Mr. Balmer's communication on the spectral lines of atomic hydrogen. I was delighted to find that his formula is a special case of mine, with the same value of R , and with $c = 0$." Hence for the

hydrogen atom the equation has a simpler form:

$$\frac{1}{\lambda} = R \left[\frac{1}{m^2} - \frac{1}{n^2} \right]$$

When the appropriate values of m and n are substituted in this formula, it yields the wavelengths of all the lines in the hydrogen spectrum.

Atomic Structure

In 1912 Niels Bohr spent most of the year at the University of Manchester working in the laboratory of Ernest Rutherford, who had just made a vital contribution to the understanding of atomic structure. By then the Balmer and the Rydberg formulas were well known to spectroscopists, and they had been thoroughly tested, but Bohr had never heard of either of them. When he was told of Balmer's equation, he was able to derive it almost immediately from the properties of the hydrogen atom. Abraham Pais and T. D. Lee have reported that Bohr was asked late in his life how he could have escaped knowing of the Balmer formula. He explained that in those days most physicists regarded atomic spectra as being so complicated they were hardly a part of fundamental physics. They were thought

of, he said, as being like the notes of a piano, whose tones depend in a complicated way on the structure of the instrument as a whole.

The reference to musical notes was not an idle one. In the 19th century many investigators had speculated that the light emitted by atoms might be understood by some analogy to the modes of vibration of a solid body. The presence of multiple lines in each series could then be explained by assuming that the first line was the fundamental mode and the rest were overtones, or harmonics. No optical spectrum could be resolved into a fundamental frequency and its overtones, however, and so more direct examination of the atom itself was undertaken.

Rutherford's contribution was the demonstration that the atom is not a solid body but rather consists of a small, dense, positively charged nucleus and the requisite number of negatively charged electrons to form a stable and electrically neutral system. Bohr undertook to explain the spectra of atoms in the context of this model. In doing so he risked the ridicule of his contemporaries by hypothesizing that within the atom the established laws of physics do not apply. Those laws predicted that any bound electron would radiate away all its energy and fall into the nucleus. Bohr

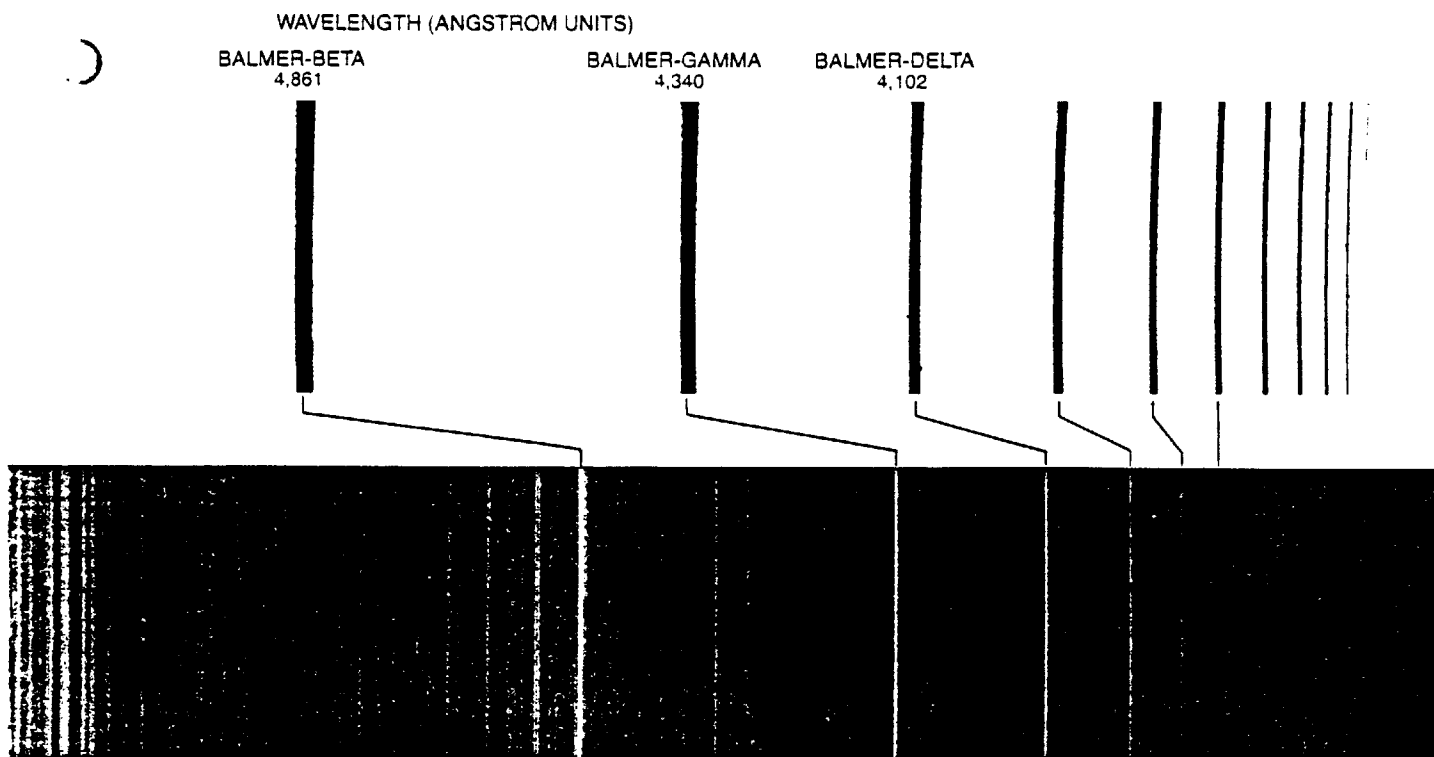

in the latter's laboratory at Stanford University. The black-and-white spectrum was recorded in 1927 by Gerhard Herzberg, who was then at the Darmstadt Technical University in Germany. The intervals between the lines are different in the two photographs because Brenneis and Schawlow dispersed the light with a diffraction grating, whereas Herzberg employed a prism; the prism introduces a distortion because the refractive index of glass is a nonlinear function of wavelength. In both cases the source of the spectrum was a gas-dis-

charge tube in which hydrogen molecules (H_2) are dissociated into atoms by an electric potential. In the color photograph the yellow and green bands and the continuous blue background at the right are not part of the atomic-hydrogen spectrum but result from molecular contaminants in the discharge tube. Herzberg eliminated such contamination by cooling the tube in liquid nitrogen. Lines to the right of Balmer-delta, which appear white or light blue in the color photograph, are actually in the ultraviolet region of the electromagnetic spectrum.

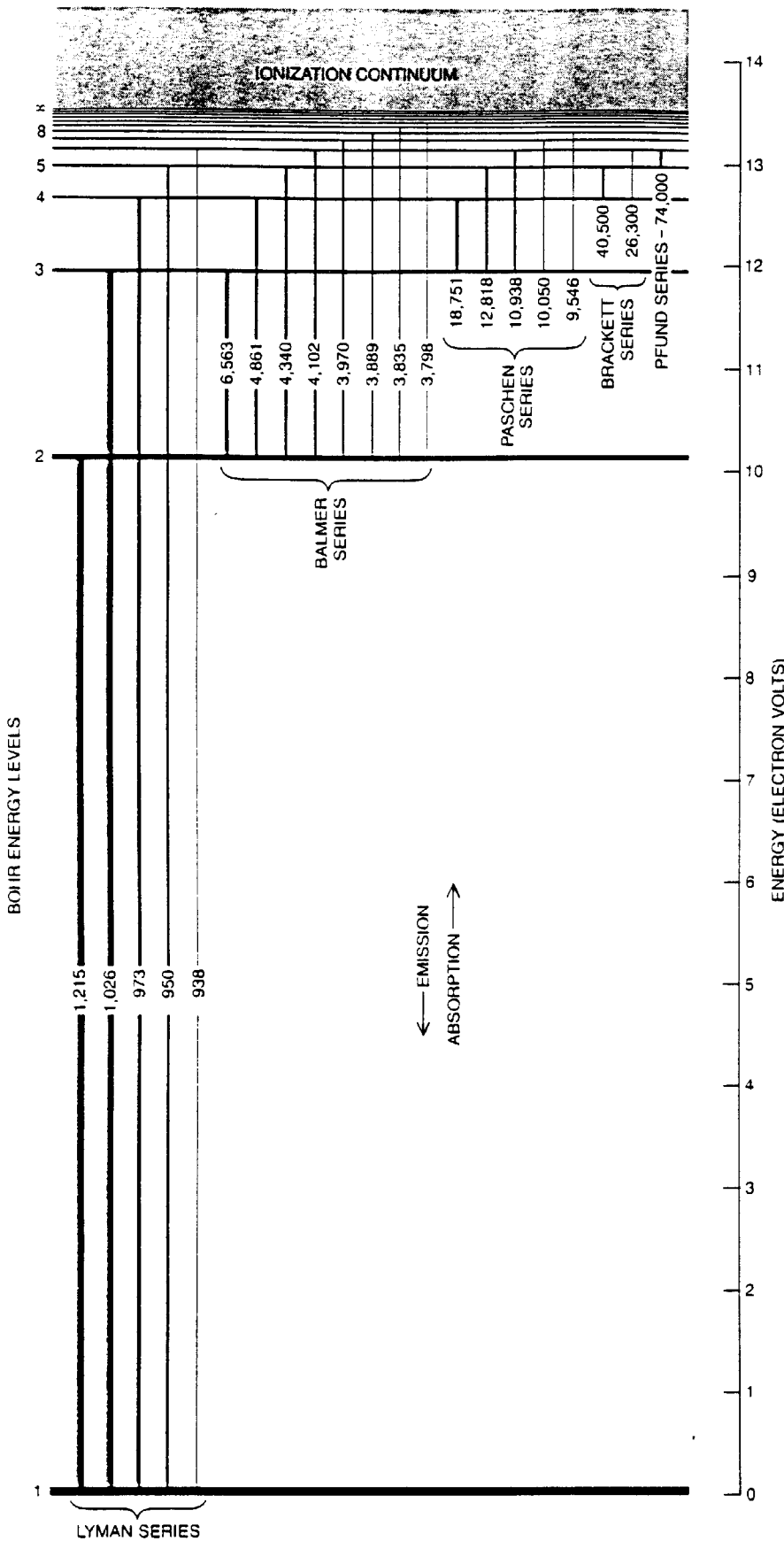

TRANSITIONS BETWEEN STATES of the hydrogen atom give rise to the line spectrum. Each state is designated by an integer, called the principal quantum number of the corresponding Bohr energy level. When an atom changes from one state to another, the difference in energy appears as a quantum of radiation. The energy of the quantum is directly proportional to the frequency of the radiation and inversely proportional to the wavelength. Absorption of radiation stimulates a transition to a state of higher energy; an atom falling to a state of lower energy emits radiation. The spectrum is organized into series of lines that share a lower level. Wavelengths are given in angstroms; the relative intensity of the lines is indicated by thickness.

proposed that an atom could exist in a state where the energy of the electron was not dissipated: a stationary state. Light is emitted or absorbed, he suggested, only when an electron moves from one stationary state to another. The frequency of the light is determined by the difference in energy between the two states, according to the quantum principle introduced by Max Planck. The frequency is found by dividing the energy difference by Planck's constant, which is designated h .

In Bohr's model the Balmer and the Rydberg formulas have an obvious physical interpretation. The expression $(1/m^2 - 1/n^2)$ is proportional to the difference in energy between two states of the atom: the integers m and n label the states themselves. Bohr did more than just explain this empirical equation, however: he went on to evaluate the Rydberg constant in terms of three fundamental quantities, the electric charge of the electron, e , the mass of the electron, m , and Planck's constant, h . If for the sake of simplicity the nucleus of an atom is assumed to be infinitely massive, then the Rydberg constant is given by the equation

$$R = \frac{2\pi^2me^4}{h^2}$$

Later refinements have complicated Rydberg's empirical formula for the wavelengths of spectral lines, and so the Rydberg constant is now defined as this combination of m , e and h .

Bohr imagined that the electrons in an atom follow circular orbits. In calculating the energy of the stationary states he began with the assumption that for orbits of very large diameter the frequency of the emitted light should correspond to the frequency of the orbiting electron, which was a prediction of classical physics. This "correspondence principle" led to the intriguing conclusion that for a stationary state designated by the integer n the angular momentum of the orbiting electron is equal to $nh/2\pi$. Hence the angular momentum, like the energy, can change only in discrete steps. This "quantization" of the angular momentum is of fundamental significance: without it the atom could radiate at any frequency and the state would no longer be stationary.

Quantum Mechanics

The Bohr atom was a great conceptual advance over earlier theories, but it soon proved inadequate to explain the observed features of atomic spectra, even those of the simplest spectrum, that of hydrogen. Indeed, one detail of the hydrogen spectrum that the Bohr theory could not account for had been known for 20 years when the model was constructed. In 1892 A. A. Michelson had employed the interferometer he had

invented to examine the shapes of individual spectral lines, that is, their variation in intensity as a function of wavelength. He had found that the Balmer-alpha line is not a single line at all but rather has two components, separated in wavelength by .14 angstrom.

Bohr suggested that the splitting of the Balmer-alpha line might be explained if the electron's orbit in the hydrogen atom is not circular but elliptical. A correction to the orbital motion required by the special theory of relativity would then split each stationary state into a group of states. A more comprehensive discussion of this idea was subsequently presented by Arnold Sommerfeld, who deduced the observed splitting from the calculated properties of the orbits. In his calculation he introduced an important dimensionless number called the fine-structure constant, equal to $2\pi e^2/hc$. The numerical value of this constant, about $1/137$, has been a source of speculation for physicists ever since.

A more satisfactory treatment of the line splitting was not possible until quantum mechanics was introduced in the 1920's. Two formulations of quantum mechanics were devised, one by Erwin Schrödinger and the other by Werner Heisenberg and Max Born: they were soon found to be mathematically equivalent. An essential idea in both formulations was that the motion of an electron cannot be defined precisely but must be described in terms of probabilities. Both theories predicted the Bohr energy levels of the hydrogen atom, and hence the same wavelengths of the spectral lines, and the predictions could be extended to more complicated atomic systems. Again relativistic corrections had to be introduced in order to explain the splitting of the hydrogen lines.

By the 1920's, however, better measurements of the shape of lines in the hydrogen spectrum were available, and it soon became plain that a further adjustment to the theory was needed. The adjustment was made when it was rec-

SPLITTING OF ENERGY LEVELS results mainly from relativistic and magnetic interactions related to angular momenta in the atom. The single electron of a hydrogen atom can have both orbital and spin angular momentum, and the various possible combinations of these quantities generally have different energies. As a result the Bohr energy levels are split into components called the fine structure of the levels. A subtle effect called the Lamb shift displaces certain of the fine-structure components, creating additional splittings. Finally, the interaction of the electron's magnetic moment with that of the nucleus gives rise to a hyperfine structure. The fine structure and the Lamb shifts are shown here at a larger scale than the Bohr levels, and the hyperfine splittings of the second and third Bohr levels are shown at still greater magnification.

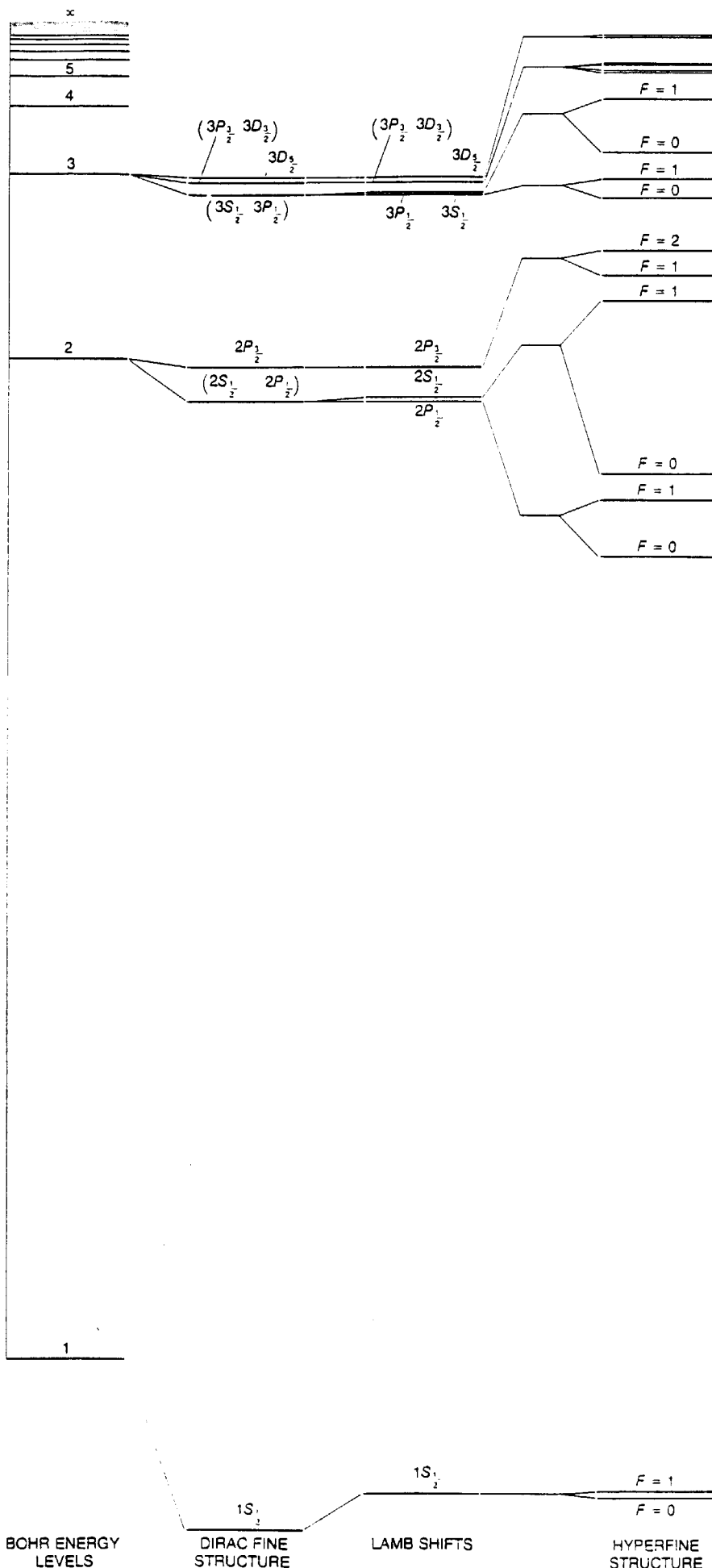

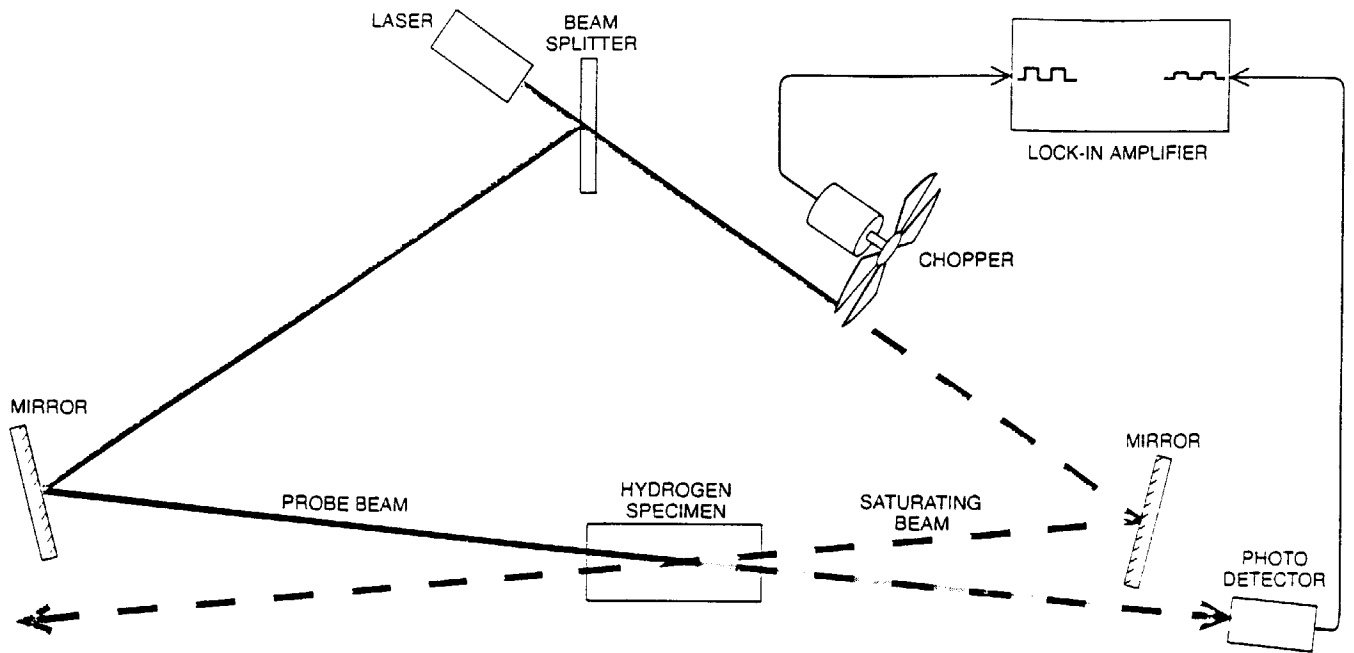

SATURATION SPECTROSCOPY suppresses Doppler broadening by labeling a group of atoms that happen to have no component of motion along the optical axis. The light from a dye laser is split into an intense saturating beam and a weaker probe beam, which pass through a specimen of atomic hydrogen in opposite directions. The saturating beam is strong enough to reduce significantly the population of atoms in the state capable of absorbing the laser wavelength: the beam bleaches a path through the gas. The probe beam therefore

encounters a smaller absorption and registers a higher intensity at the detector. The two beams can interact in this way, however, only when they are both absorbed by the same atoms in the gas, and that can happen only when they are both tuned to the wavelength of atoms that have no Doppler shift. In practice the saturating beam is interrupted by a mechanical "chopper," and enhancement in the transmission of the probe beam is detected by tuning the laser through a range of wavelengths and searching for a signal at the chopping frequency.

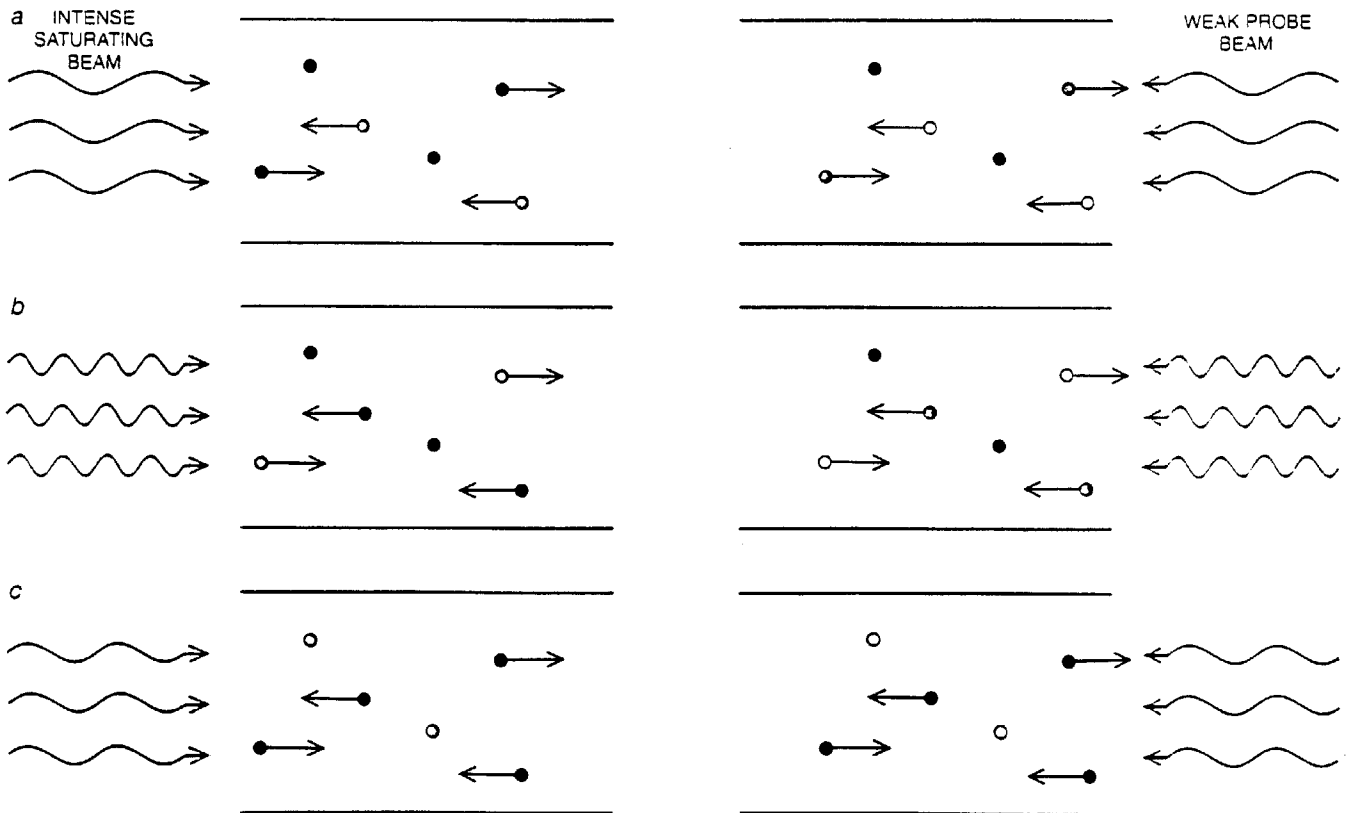

COUNTERPROPAGATING BEAMS from a tunable dye laser undergo opposite Doppler shifts. When the frequency of the saturating beam (measured in the laboratory frame of reference) is below that of some selected component of the spectrum (a), only atoms moving to the left can absorb the light, because their motion shifts the frequency into resonance with the atomic transition. The probe beam, with the same frequency, is absorbed only by atoms moving to the right, and so it is not affected by the saturating beam. When the laser frequency is above that of the spectral component (b), the saturating

beam is absorbed by atoms moving to the right and the probe beam by atoms moving to the left, which are again different groups of atoms. Only when the laser frequency matches the atomic-transition frequency (c) do the two beams interact with the same atoms: those atoms that are effectively standing still. The probe beam then finds that the atoms that might have absorbed it are unable to do so because they have already absorbed radiation from the saturating beam. Transmission of the probe beam therefore increases. Only the component of motion that is directed along the optical axis is depicted.

ognized that the electron can acquire angular momentum not only by orbiting the nucleus but also by spinning on its axis. The concept of electron spin was introduced by George Uhlenbeck and Samuel A. Goudsmit to explain measurements of the spectra of alkali-metal atoms. By including electron spin in the theory it was possible to predict with reasonable accuracy not only the wavelengths of the spectral lines but also their intensities; that had not been true for the Bohr-Sommerfeld theory. In 1928 the concept of spin for the electron—and also for the proton and the neutron—was given a more secure foundation when P. A. M. Dirac found a new way of constructing a theory of quantum mechanics that is also consistent with the special theory of relativity. In the Dirac theory electron spin appears as a natural consequence of the basic equations rather than as a special postulate. The magnitude of the spin angular momentum is $1/2 h/2\pi$.

Fine Structure

The relativistic quantum mechanics of Dirac predicts the structure of the hydrogen spectrum in great detail. As in earlier theories each basic energy level is designated by an integer, n , which is called the principal quantum number. For the lowest energy level (the ground state of the atom) n is equal to 1, for the first excited state n is equal to 2 and so on. These integers are the same ones that appear in Rydberg's formula for the spectral lines.

The basic lines of the spectrum—ignoring for the moment any splitting into finer components—are generated by transitions between states that have different principal quantum numbers. The Balmer-alpha line, for example, results from transitions between the states $n = 2$ and $n = 3$. If a hydrogen atom falls from $n = 3$ to $n = 2$, it emits light at the wavelength of the Balmer-alpha line; if the atom then absorbs a quantum of light at the same wavelength, it makes the opposite transition, from $n = 2$ to $n = 3$. All the lines in a series share a common lower state. The transitions that give rise to the Balmer series connect states with principal quantum numbers of 2 and 3, 2 and 4, 2 and 5 and so on. In the Lyman series all the transitions begin at the state $n = 1$.

The basic lines of the hydrogen spectrum reflect the dominant interaction in the hydrogen atom: the electrostatic attraction between the nucleus and the electron. The splitting of each line reflects subsidiary interactions, relativistic effects and magnetic effects. The magnetic effects come about because the spinning electron, acting as a magnet, is subjected to a magnetic field attributable to the effective motion of the charged nucleus around the electron. This splitting is called the fine structure

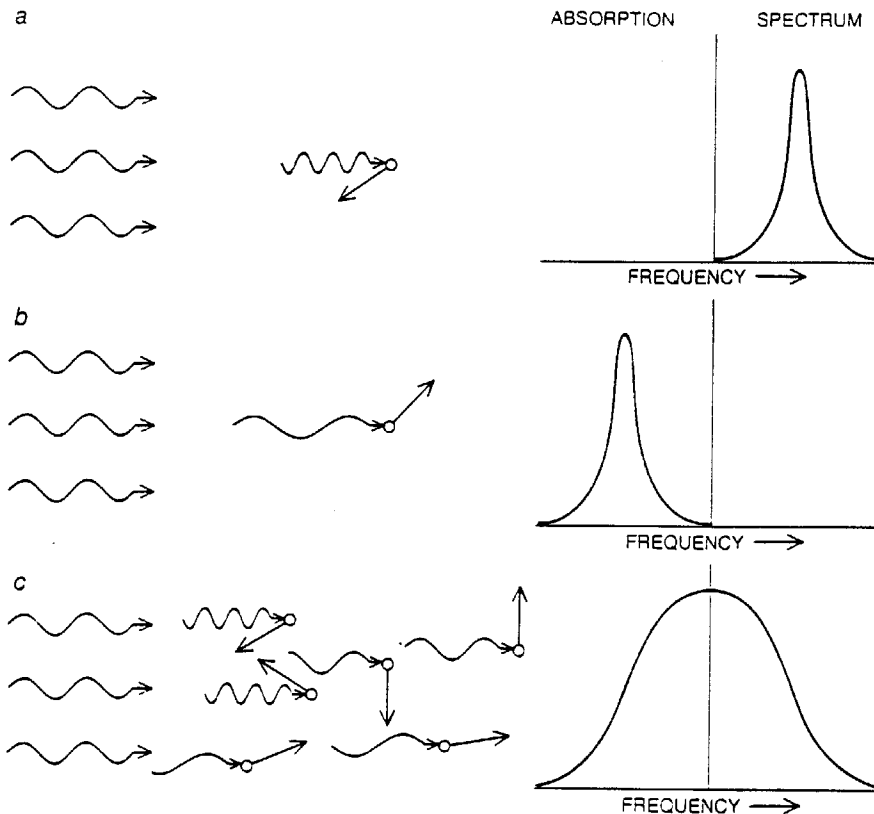

DOPPLER BROADENING obscures many details of the hydrogen spectrum by smearing each narrow component over a band of wavelengths. Because the atoms of a gas have random velocities, at any given moment some are moving toward a source of light and others are moving away from it. For an atom moving toward the source (a) the light appears to have a higher frequency (or shorter wavelength) than it does in the laboratory frame of reference. For an atom moving away (b) the frequency is shifted down. As a result of these Doppler effects the measured frequency of a spectral component is different for atoms that have different velocities. The absorption profile for all the atoms in the gas (c) is not a sharp peak but a broad curve.

of the spectrum. Because the nucleus itself also has spin and acts as a magnet, it interacts with the magnetic field arising from the motion of the electron's charge and also from the proximity of the electron's magnetic field. These magnetic interactions are on a still smaller scale, and the corresponding splittings of the spectral lines are called the hyperfine structure.

A system of classification has been developed for the fine and hyperfine energy levels, which specifies the magnitudes of the various angular momenta (orbital, electron-spin, nuclear-spin and total) in a stationary state. The principal quantum number, which corresponds to the Bohr energy level, is given by one of the integers in the sequence beginning 1, 2, 3, ... To this number is appended a letter, such as *S*, *P*, *D* or *F*, which is related to the orbital angular momentum: the letters stand for integers in the series beginning 0, 1, 2, 3, ... A third symbol, which for the hydrogen atom is always a fraction such as $1/2$, $3/2$ or $5/2$, is related to the sum of the orbital and spin angular momenta. If an analysis is subtle enough to reveal the hyperfine structure (an interaction that depends on the magnetic properties of the nucleus), a fourth label, represented by the symbol *F*, is also needed. It is related to the sum of the orbital, electron-spin and nu-

clear-spin momenta. Generally, stationary states that differ in any label have different energies, although that is not always the case.

The fine structure splits the $n = 2$ state of the hydrogen atom into three sublevels and the $n = 3$ state into five sublevels. A simple tabulation of the possible combinations of these levels implies that there could be 15 components of the Balmer-alpha line. Actually several of these transitions are forbidden by conservation laws, and the Dirac theory predicts that the line should have seven components. At the time Dirac proposed his theory experimenters could clearly recognize only two components, although in 1925 G. Hansen detected a third component as a broadening on the side of one of the others.

The factor limiting the resolution of the lines was (and still is) Doppler broadening caused by the thermal motions of the atoms. Because of the Doppler effect the light emitted by an atom appears to be shifted to a higher frequency if the atom is approaching the observer and to a lower frequency if the atom is receding. Atoms in an ordinary light source move in all directions, and so the emitted light is broadened in wavelength by the ratio v/c , where v is the average speed of the atoms and c is the velocity of light. The broadening

is exceptionally troublesome for hydrogen, whose atoms are lighter than any others and therefore move faster. At room temperature the fractional line width is about 12 parts per million. The speed of the atoms, and hence the line width, is proportional to the square root of the absolute temperature. The line width can be reduced by a factor of three or four by cooling the hydrogen discharge lamp from room temperature (300 degrees Kelvin) to the temperature of liquid hydrogen (20 degrees K.).

The Lamb Shift

In the 1930's several investigators tried to resolve the fine structure of hydrogen more completely in order to test the predictions of the Dirac theory. By then it was possible to examine the spectrum of deuterium, the hydrogen isotope with a mass twice that of ordinary hydrogen. The width of a spectral line varies inversely as the square root of the atomic mass, and so the width is reduced in a deuterium spectrum by a factor of about 1.4. Even so, no additional components of the Balmer-alpha line were resolved, and the third component was still not completely separated from its stronger neighbor.

In the course of these investigations, however, some observers reported small discrepancies between the measured spectra and the predictions of the Dirac theory. Of particular interest was the pair of fine-structure levels $2S_{1/2}$ and $2P_{1/2}$. These levels differ in orbital angular momentum and therefore in the average geometrical distribution of the electron, but they have the same total angular momentum and the Dirac theory predicts they should lie at the same energy. Thus although they are distinct

states, they should not give rise to any splitting in the spectrum. Simon Pasternack interpreted experiments carried out by Robley C. Williams and by William V. Houston and his colleagues as showing that the $2S_{1/2}$ and $2P_{1/2}$ levels do not exactly coincide. Others, however, disagreed.

The question was settled in 1947 in a brilliant experiment conducted by Willis E. Lamb, Jr., and Robert C. Retherford. They found that the $2S_{1/2}$ level was shifted upward with respect to the $2P_{1/2}$ level by about 1.060 megahertz, or millions of cycles per second. Compared with the frequency of the Balmer-alpha line, which is about 450,000 gigahertz (billions of cycles per second), that is a shift in the position of the $2S_{1/2}$ component by a factor of little more than two parts per million.

Lamb and Retherford did not attempt to resolve the two components in the optical spectrum. Instead they employed radio-frequency energy to stimulate a direct transition between the $2P_{1/2}$ and the $2S_{1/2}$ levels. The frequency of the radio waves is 500,000 times lower than the frequency of the Balmer-alpha line; since the Doppler broadening of the line is reduced by the same factor, it could be neglected entirely. This small splitting of the energy levels is now called the Lamb shift.

The need to supply an explanation for the Lamb shift inspired another fundamental revision of physical theory, introduced by Richard P. Feynman, Julian Schwinger and Sin-itiro Tomonaga. Their point of departure was the novel idea that the electrons observed in experiments may differ in certain properties, such as mass and charge, from the hypothetical "bare" electron that is imagined to exist in an empty universe.

This difference, which had previously been ignored, can alter the properties of an electron in a bound system. The theory that results from these ideas is called quantum electrodynamics.

In quantum electrodynamics the Lamb shift arises from an interaction between the electron and "zero-point fluctuations" of the electromagnetic field. Such fluctuations, which are always present, cause the electron to jitter about, so that it perceives the nucleus as being somewhat smeared out in space. The result is a seeming alteration of the force between the two particles when they are close together. Because the electron spends more time near the nucleus in the S state than it does in the P state, the energy of the S state is slightly increased.

This model of the hydrogen atom has a further complication. If the electron is regarded as a pointlike particle, it can respond to fluctuations of infinitely high frequency, which have infinite energy. The infinities are avoided, and so is the need to answer questions about the size and structure of the electron, by comparing an electron bound in an atom with a hypothetical bare electron. The small measured energy is found by subtraction. Such calculations are complex, but the predictions of the theory are exceedingly accurate. Indeed, quantum electrodynamics is the most precise theory ever devised, and no discrepancies with experiment have been found.

The fine-structure splitting of various energy levels of the hydrogen atom has been revealed in considerable detail through measurements at radio frequencies. At the same time improved spectroscopic methods have led to precise determinations of the Rydberg constant from measurements of the wavelength

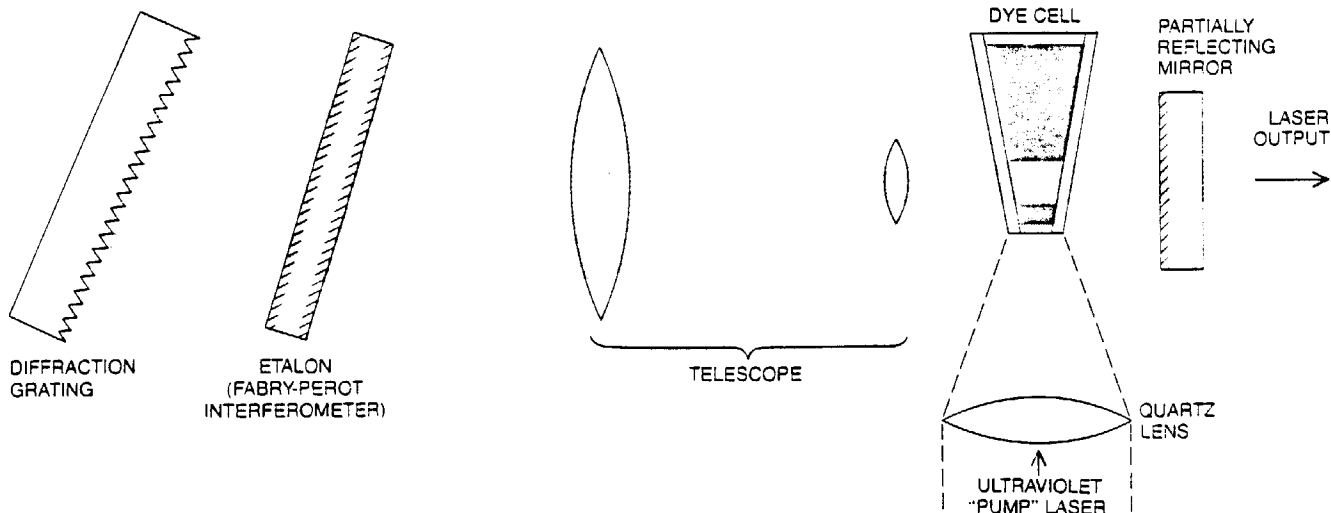

DYE LASER emits light that can be confined to a narrow range of wavelengths but can also be tuned over a broad range. The laser medium is a fluorescent dye that emits light with a wide and essentially continuous spectrum when the dye is "pumped" by another laser. From this broad emission band a much narrower interval of wavelengths is selected for amplification by an optical cavity that is tuned to resonate at a particular frequency. Coarse tuning is provided by

a diffraction grating, which disperses the light so that only selected wavelengths are reflected back into the dye cell. An etalon further narrows the bandwidth by passing only those wavelengths that interfere constructively during many internal reflections. A telescope in the cavity spreads the beam so that many grooves of the grating are illuminated. The monochromatic but tunable light has been employed in spectroscopic measurements that eliminate Doppler broadening.

of one component of the Balmer-alpha line. Bryan P. Kibble, William R. C. Rowley, Raymond E. Shawyer and one of us (Series) employed a light source cooled in liquid helium to determine the Rydberg constant to a precision of better than one part in 10 million. Even the Lamb shift was observed in 1948 by one of us (Series), and similar shifts were measured in ionized helium by one of us (Series), by Gerhard Herzberg and by Frederick L. Roesler. The accuracy of the optical experiments, however, does not approach that of the radio-frequency methods.

Width of Spectral Lines

Although these experiments have been highly successful, the hydrogen atom is such a fundamental testing ground for the laws of physics that it is important to probe deeper as new techniques become available. For now the most promising approach is to improve the resolution of measured spectra: it is resolution that limits the sharpness of observed spectral lines and thereby limits the precision with which their wavelengths can be determined.

The earliest spectroscopic studies of atoms were limited by the resolution of the instrument itself, which was simply a prism or a diffraction grating, a glass plate ruled with many closely spaced lines. The grating has the effect of dispersing light by reflecting different wavelengths through different angles. If the entire visible spectrum is dispersed through, say, 15 degrees, then some components of the Balmer-alpha line might be separated by less than .05 second of arc.

With the application of interferometers to the examination of spectral lines the intrinsic instrumental limitation was removed. The interferometer invented by Michelson and another type devised by the French opticians Charles Fabry and Alfred Perot are sensitive instruments for comparing two wavelengths. They are capable of distinguishing two sharp peaks that differ in frequency by one gigahertz or less. Interferometers fail to fully separate the several components of the Balmer lines not because the instruments are inadequate but because the components themselves are not sharp. Each component is distributed over a range of wavelengths that is often greater than the spacing between the components.

A part of the broadening is the "natural" width of the spectral line. Even under the best possible circumstances of observation no component of a spectrum can ever be absolutely monochromatic. This limitation stems from the fact that the "stationary states" of an atom are not truly stationary. Atoms do, in fact, radiate energy after a finite lapse of time. This is simply to say that excited states do eventually decay.

The natural line width sets an ultimate limit on spectroscopic resolution, but until recently the limit has seldom been approached. That is because the lines are broadened to a much greater extent by another effect: the Doppler shifting of frequencies as a result of the motion of the atoms.

One method of greatly reducing Doppler broadening is to measure the spectrum not of a gas but of a collimated atomic beam. Such a beam can be created by allowing the atoms of a gas to escape from a vessel through a series of pinhole openings. All the atoms that can pass through the holes will be moving in

the same direction, and so light crossing the beam at right angles to the beam will show only small Doppler shifts. The number of atoms in the beam, however, declines as the collimation improves. Moreover, it is not always possible to prepare a beam of atoms in the necessary state. To study the Balmer spectrum of hydrogen by absorption, for example, the atoms must be in the $n = 2$ state: such atoms cannot be formed into beams dense enough for conventional spectroscopic measurements.

The techniques of laser spectroscopy introduced since about 1970 have significantly improved resolution because

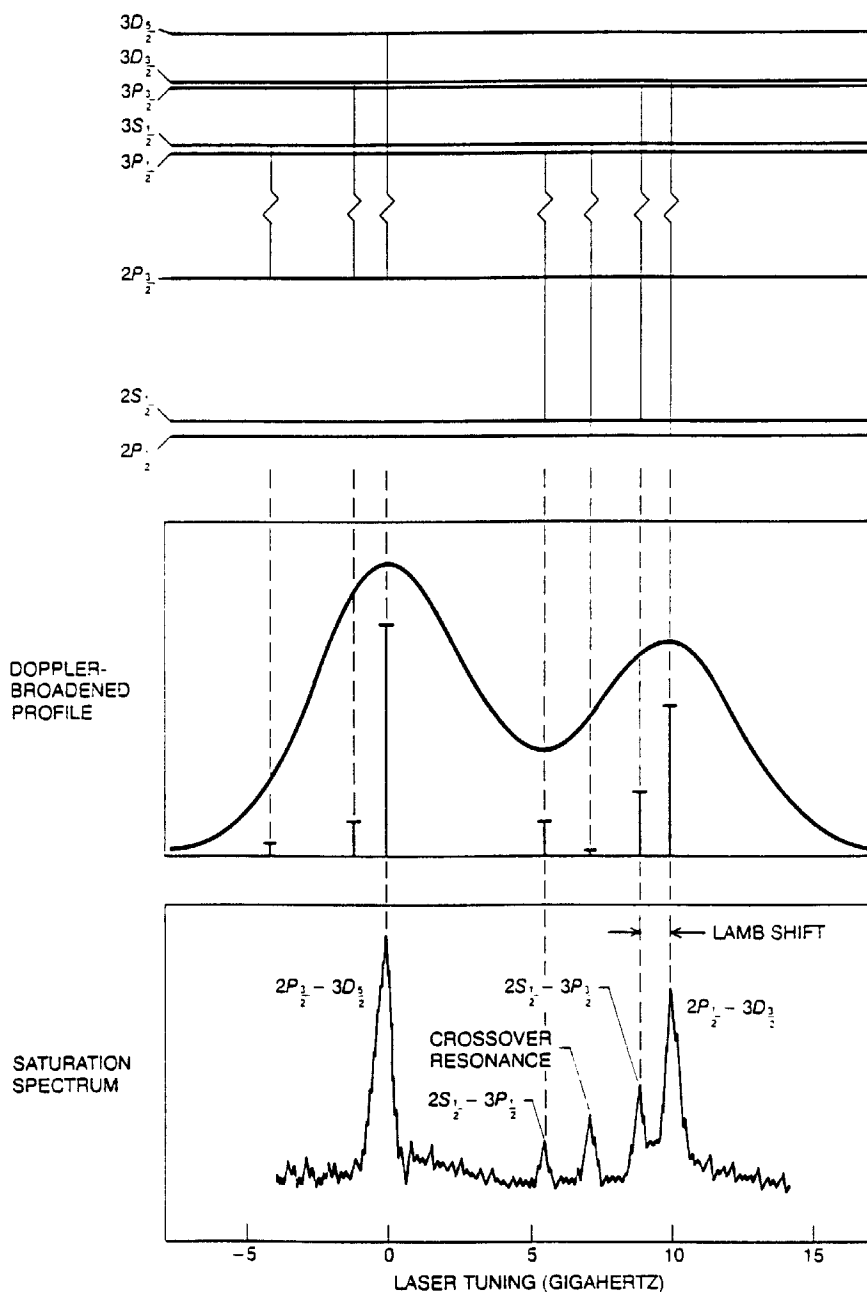

BALMER-ALPHA LINE is resolved into a series of sharp peaks by saturation spectroscopy. Theoretical calculations indicate that the line has seven components resulting from fine-structure splittings and the Lamb shift but ignoring the hyperfine structure of much smaller scale. In a Doppler-broadened profile of the line only two components can be distinguished. By examining only those atoms that have no Doppler shift saturation spectroscopy clearly resolves four components. (A fifth peak midway between two other peaks is an artifact called a crossover resonance.) Frequency scale measures tuning of the laser from an arbitrary starting point.

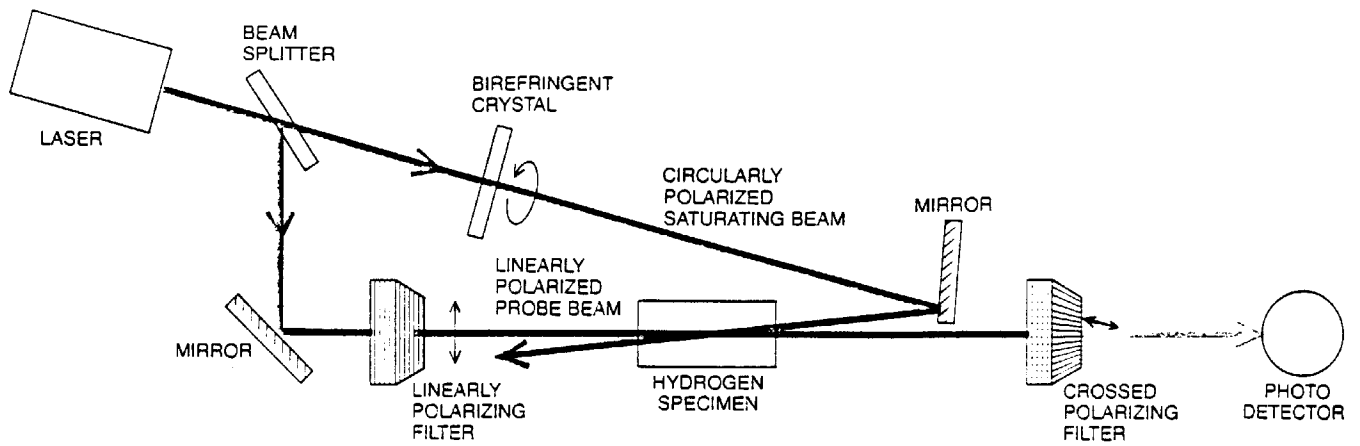

POLARIZATION SPECTROSCOPY exploits the fact that small changes in the polarization of light can be detected more easily than small changes in intensity. The output of a laser is again split into two beams, but the saturating beam is given a circular polarization and the probe beam a linear polarization. Because the probe beam encounters crossed polarizing filters very little of it can reach the detector un-

less the hydrogen gas can in some way rotate the beam's plane of polarization. Such a rotation can be introduced by the circularly polarized saturating beam, but only if the two beams interact with the same population of atoms. In this way atoms that happen to be stationary at a given moment are singled out, as in saturation spectroscopy, by the ability to interact with light waves moving in opposite directions.

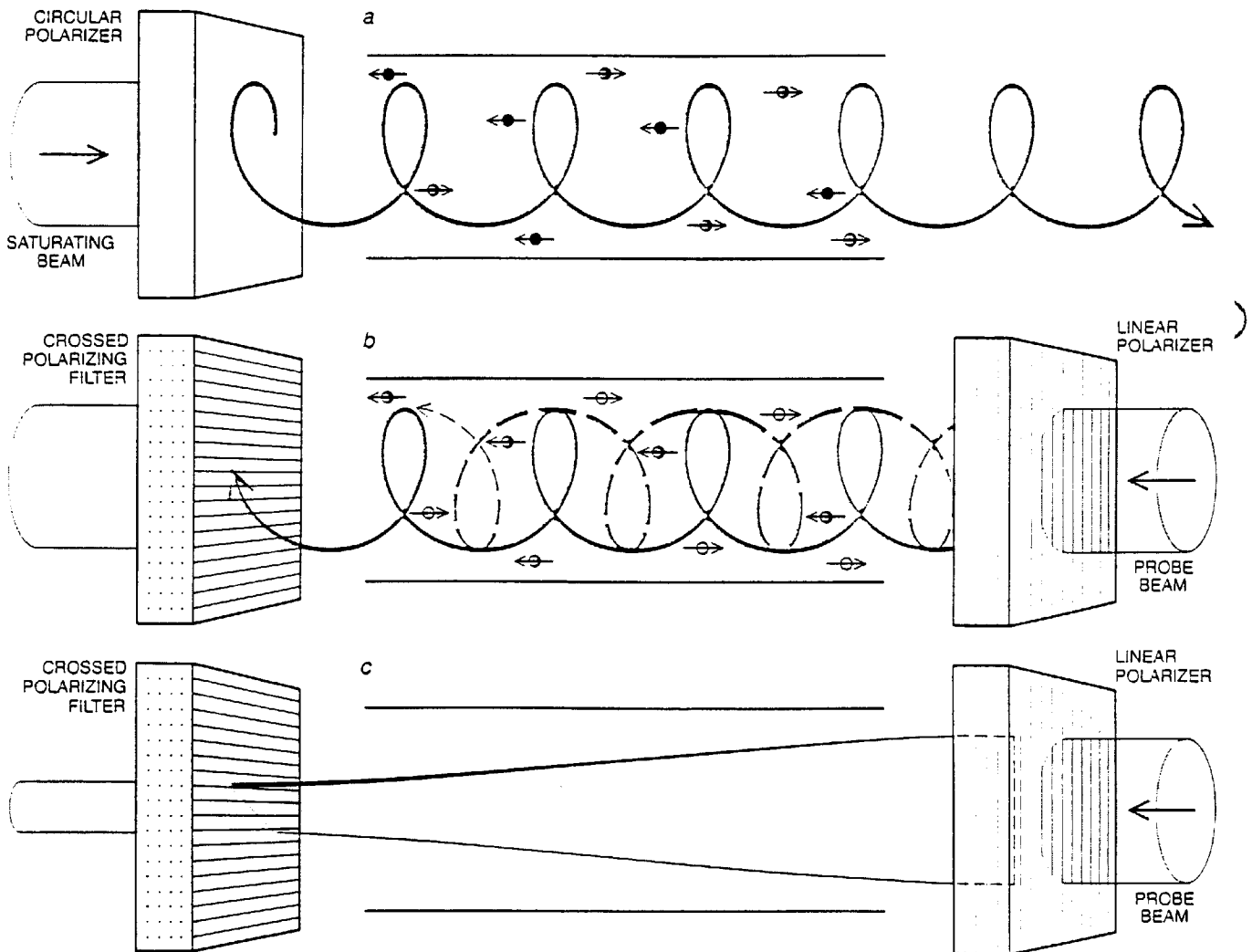

CHANGE IN THE POLARIZATION of a probe beam is induced by the prior passage of a saturating beam. Because the saturating beam is circularly polarized it is selectively absorbed by atoms that have a particular orientation (a), and those atoms are thereby removed from the population of atoms that can absorb radiation at the laser wavelength. Most of the remaining atoms have the opposite orientation. The linearly polarized probe beam can be regarded as a combination of two circularly polarized waves that have the opposite sense of rota-

tion but equal intensity (b). When the probe beam passes through the specimen, one of the circularly polarized components is more strongly absorbed because the atoms have a prevailing orientation. The selective absorption of one circularly polarized component changes the polarization of the remaining light (c), and so a portion of the probe beam can penetrate the analyzing filter. The change in polarization can take place, however, only if the two beams are absorbed by the same population of atoms, namely those that have no Doppler shift.

they include methods for eliminating Doppler broadening. Three such methods will be discussed here. Two of them work by selecting for observation only those atoms in a gas whose component of motion along the optical axis happens to be zero. The third method allows all the atoms in a gas to contribute to a measurement, but it eliminates velocity broadening by arranging two Doppler shifts in opposite directions.

The Tunable Dye Laser

Lasers provide light of unequalled brightness, directionality and spectral purity. The early lasers, however, could emit light at only a few discrete wavelengths, determined by the spectral lines of the active atoms or ions. Such an instrument is of use in spectroscopy only if the transition to be observed happens to coincide with one of the available laser lines.

In 1966 Peter Sorokin of the Thomas J. Watson Research Center of the International Business Machines Corporation and independently Fritz Schäfer of the University of Marburg discovered that liquid solutions of certain fluorescent organic molecules can serve as the medium for a laser with a broad and continuous band of wavelengths. The organic molecules are dyes, which by nature have intense absorption bands: that is why they are strongly colored. In the laser the dye molecules are "pumped," or driven to an excited state, by an intense external light source, such as another laser.

Although the dye laser is capable of amplifying light over a wide range of wavelengths, it was soon learned that a particular wavelength could be selected by designing an optical resonator that will allow only the chosen wavelength to pass repeatedly through the amplifying dye cell. In 1970 one of us (Hänsch) devised a simple pulsed dye laser of high spectral purity. The dye, enclosed in a glass cell, was pumped by pulses of ultraviolet radiation from a nitrogen laser. The resonator consisted of a partially reflecting glass plate at one end of the laser and a diffraction grating at the other. The grating disperses the light emitted by the dye, with the result that only a narrow range of wavelengths is reflected back along the optical axis. A telescope in the laser cavity expands the beam before it strikes the grating, so that many grooves are illuminated with well-collimated light. The line width of the laser is further reduced by inserting a tilted Fabry-Perot interferometer into the cavity. The interferometer is made up of two partially reflecting surfaces whose spacing is precisely controlled; the type of interferometer placed in the laser resonator is called an etalon, and it consists of a single glass plate whose two parallel surfaces are coated with partially reflecting layers. Light waves with dif-

ferent wavelengths take slightly different paths through the etalon. As a result of multiple internal reflections some wavelengths interfere destructively and are extinguished, whereas other wavelengths interfere constructively and are reinforced.

The line width of this laser is a few thousandths of an angstrom, or about one part per million, which is comparable to the resolution of the largest grating spectrographs. The width can be further reduced by a factor of 100 or so by a second Fabry-Perot interferometer outside the laser cavity, which acts as a passive filter. Although at any given setting the light is highly monochromatic, the laser can be tuned over the full range of the dye absorption profile. Gross tuning can be accomplished by changing the angle of the diffraction grating or of the etalon. Finer adjustments can be made by enclosing the grating and

the etalon in an airtight chamber and altering the pressure, which changes the index of refraction of the enclosed gas.

Saturation Spectroscopy

There is an ultimate limitation on the wavelength resolution of any pulsed laser. The precision with which the wavelength can be known is determined by the number of cycles available for measurement, and hence by the length of the pulse. Narrower lines require a continuous-wave laser. In 1970 Otis G. Peterson, Sam A. Tuccio and Benjamin B. Snavely of the Eastman Kodak Research Laboratories demonstrated the first continuous-wave tunable dye laser. Its principles of operation were the same as those for the pulsed dye laser, but the dye solution was made to flow rapidly in order to avoid overheating. Highly refined continuous-wave dye lasers are

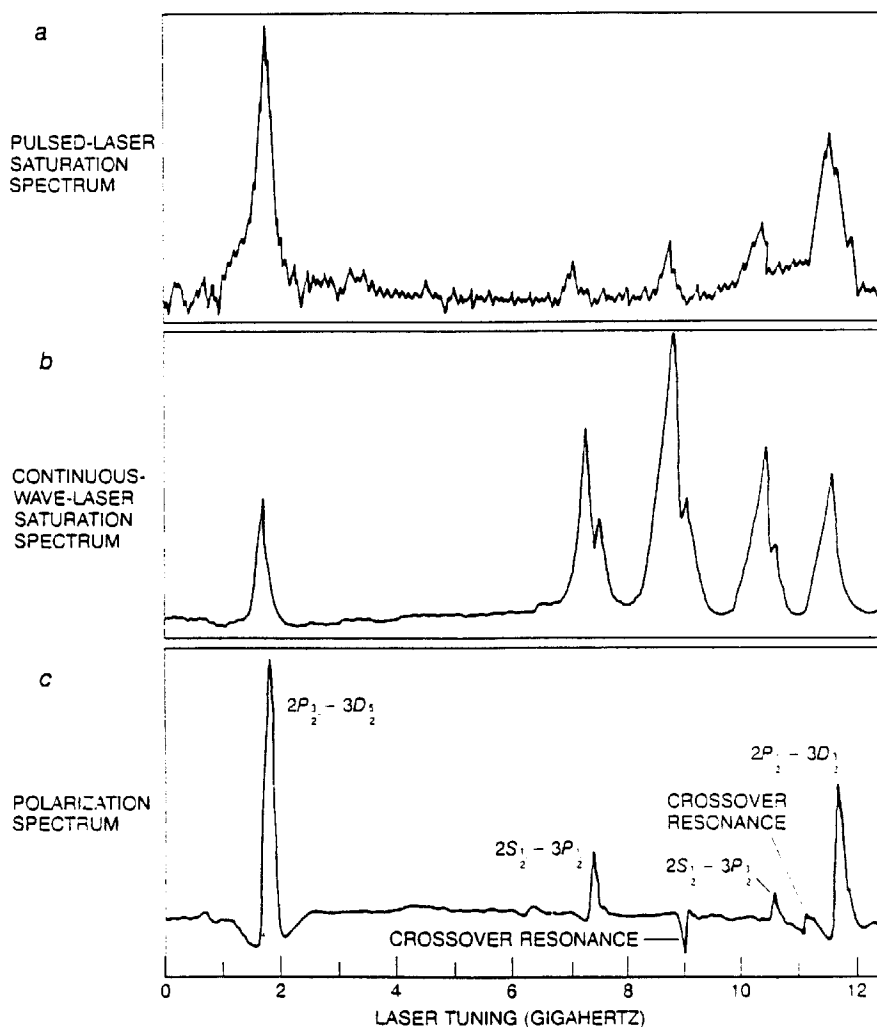

HIGHER-RESOLUTION SPECTRUM of the Balmer-alpha line was recorded by polarization spectroscopy. For comparison saturation spectrum shown on page 9 is repeated at the top and an improved saturation spectrum, made with a continuous-wave laser instead of a pulsed one, is given in the middle. In the polarization spectrum no additional components can be detected, but the four peaks that are resolved are much sharper. The two small peaks between the tall outer ones (excluding crossover resonances) have a measured width of about 35 megahertz, almost 10 times narrower than corresponding lines in the pulsed saturation spectrum. The polarization spectrum has an unusual appearance (it makes excursions below the background level as well as above it) because the graph records not the intensity of transmitted light but the rate of change in intensity as the laser is scanned through its frequency range.

now available commercially. In several laboratories line widths as small as a few parts in 10^{12} have been achieved through electronic stabilization of the laser frequency.

Given a source of light that is monochromatic but tunable, an absorption spectrum can be measured by passing the light through a sample of the gas and scanning continuously through the frequencies surrounding a line in the spec-

trum. The intensity of the transmitted light can be monitored by a photoelectric detector, which should reveal a dip at the wavelength of each component of the line. This scheme, however, would merely measure the Doppler-broadened profile of the line. To take full advantage of the potential resolution of the laser some means must be found for eliminating Doppler shifts.

One such method has been given the

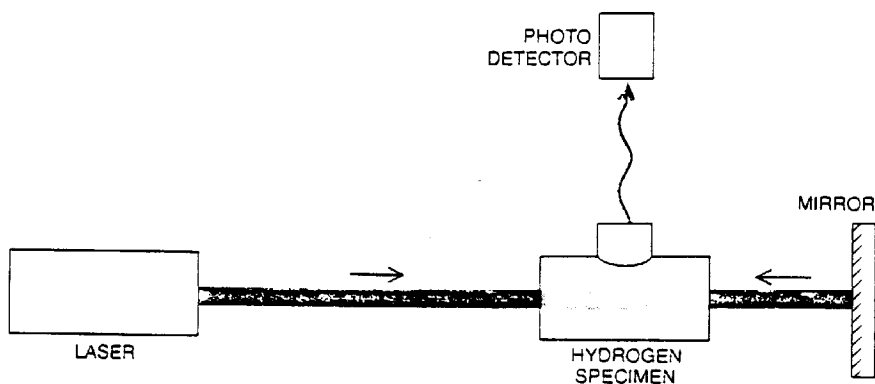

TWO-PHOTON SPECTROSCOPY does not select atoms without a Doppler shift but instead cancels the Doppler shifts of all the atoms in a gas. The dye laser is tuned to a frequency exactly half that of a selected atomic transition. The beam passes through the specimen and then is reflected back on itself, creating a field of standing waves. Atoms in the gas can make the selected transition by simultaneously absorbing two photons, or quanta of light, coming from opposite directions and therefore having opposite Doppler shifts. The excited states created in this way decay to some lower energy level, emitting photons that can be detected and counted.

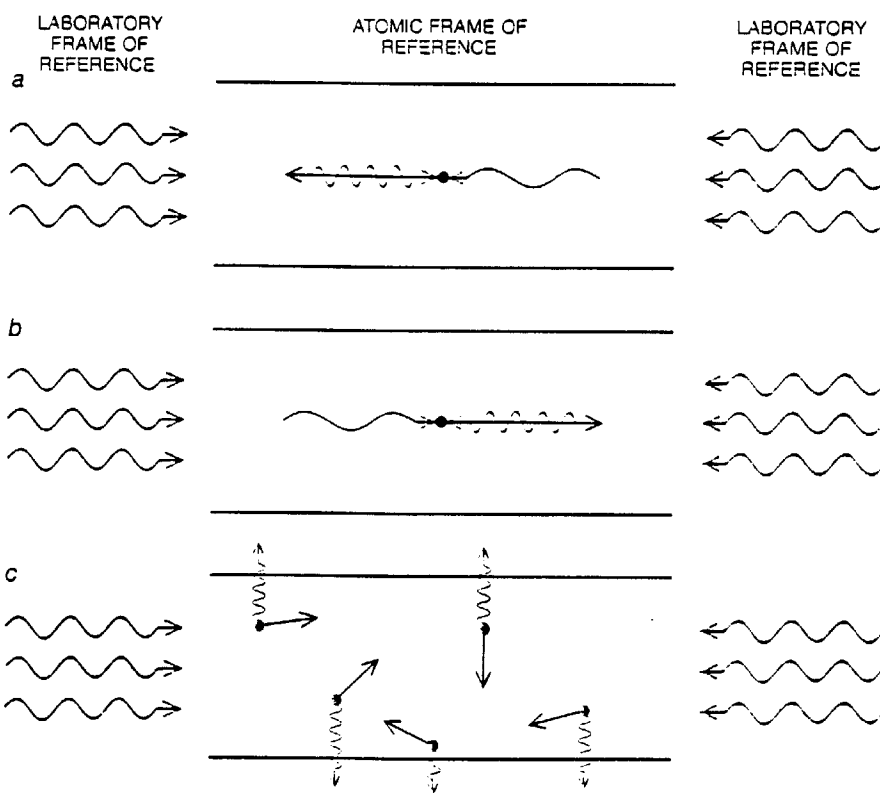

OPPOSITE DOPPLER SHIFTS CANCEL in two-photon spectroscopy. An atom moving to the left (a) sees the wave coming from the left shifted to a higher frequency, but the frequency of the wave coming from the right is shifted down by an equal amount. For an atom moving to the right (b) the frequency shifts are the opposite of these. A stationary atom perceives no Doppler shifts. Regardless of the atom's velocity the sum of the two frequencies is constant and equal to twice the laser frequency (measured in the laboratory frame of reference). All the atoms can therefore absorb two photons (c) and afterward reradiate at some higher frequency.

name saturation spectroscopy. It depends for its operation on two properties of laser light: small line width and high intensity. When an atom absorbs a quantum of light, it is excited to a higher energy level and is thereby temporarily removed from the population of absorbing atoms. In an intense beam of light the atoms of a gas may absorb quanta faster than they can return to their original state. As a result the population of absorbing atoms is substantially depleted. The light bleaches a path through the gas, and a second beam of the same wavelength would find the absorbance of the gas reduced.

Lamb was the first to recognize the potential of this effect for high-resolution spectroscopy. He pointed out that the two waves traveling in opposite directions inside a laser could work together to saturate the absorption of a particular class of atoms in the active medium of the laser. Assuming that the line width of the light is narrow enough, it must always interact only with those atoms whose motion shifts the wavelength into resonance with a component of the atomic spectrum. If the frequency of the light is lower than that of the line component, for example, then both waves in the cavity will interact with atoms moving toward them, and these will be different atoms for the two oppositely directed beams. There is one tuning of the laser, however, for which both beams interact with the same atoms: the tuning that corresponds to the exact wavelength of the spectral component, where the atoms that can absorb the light are those standing still or moving transversely to the optical axis. When the laser is tuned to this wavelength, the population of atoms in the absorbing state is depleted and the output of the laser declines. This "Lamb dip" was first observed by Ross A. McFarlane, William R. Bennett, Jr., and Lamb. It was employed for high-resolution spectroscopy by Abraham Szöke and Ali Javan of the Massachusetts Institute of Technology, but it has proved to be of limited utility. Only the laser transitions themselves can be studied, or molecular lines that happen to coincide with gas-laser wavelengths, and any gas to be examined must be placed inside the delicate resonator of a continuous-wave laser.

In 1970 Christian Bordé of the University of Paris and independently one of us (Hänsch) devised a technique for measuring saturation spectra outside the laser resonator. The light of a tunable laser is split into an intense saturating beam and a weaker probe beam. The two beams are then made to traverse the same path through a gas cell, but in opposite directions. If the laser is detuned slightly from the frequency of an atomic transition, then the two beams interact with different atoms and the saturating beam has no effect on the absorption of the probe beam. When the laser is tuned

so that it is absorbed by stationary atoms, however, the saturating beam depletes the population of atoms in the selected state and the probe beam experiences a smaller absorption. In effect the saturating beam labels all the atoms that happen to have a zero component of motion along the optical axis and ignores all others.

In practice the change in absorption is small and is easily obscured by noise. In order to help distinguish the signal from the background, the saturating beam is chopped, or interrupted at a known frequency, whereas the probe beam is allowed to operate continuously. The signal can then be detected by examining the amplitude of the probe beam for any modulation at the chopping frequency.

Two of us (Hänsch and Schawlow) with Issa S. Shahin, who was then a graduate student at Stanford University, examined the Balmer-alpha line by this method. The hydrogen atoms were excited to the absorbing $n = 2$ level in a low-pressure gas-discharge tube. The two light beams from a pulsed dye laser were passed through a section of the discharge plasma about 15 centimeters long, where they showed an absorption of about 50 percent.

Of the seven fine-structure components expected theoretically, four were visible, the two strongest ones being resolved far more sharply than in any previous spectrum. What is more, the Lamb shift that splits the $2S_{1/2}$ and $2P_{1/2}$ levels was directly observed for the first time in the optical absorption spectrum.

The saturation spectrum also included a fifth peak, but it was a spurious one, called a crossover resonance, which appears midway between any two transitions that share the same upper or lower level. When the laser is tuned to the frequency midway between these two line components, atoms moving in one direction can absorb the saturating beam, and atoms moving the other way can absorb the probe beam. As a result the absorption is saturated not by stationary atoms but by two classes of moving ones.

The sharpness of the peaks in the saturation spectrum suggested that the Rydberg constant could be determined with improved accuracy by measuring the absolute wavelength of one fine-structure component. Such a measurement was undertaken by a group of workers at Stanford led by one of us (Hänsch) and including in particular Munir Nayfeh. The component chosen was the $2P_{3/2}$ -to- $3D_{5/2}$ transition, which is the strongest one, the one with the smallest unresolved hyperfine splitting and the one least perturbed by the electric field of the discharge tube. It was first necessary to examine the effects on the line position of variations in gas pressure, in current and voltage in the discharge tube and in laser intensity, and to correct

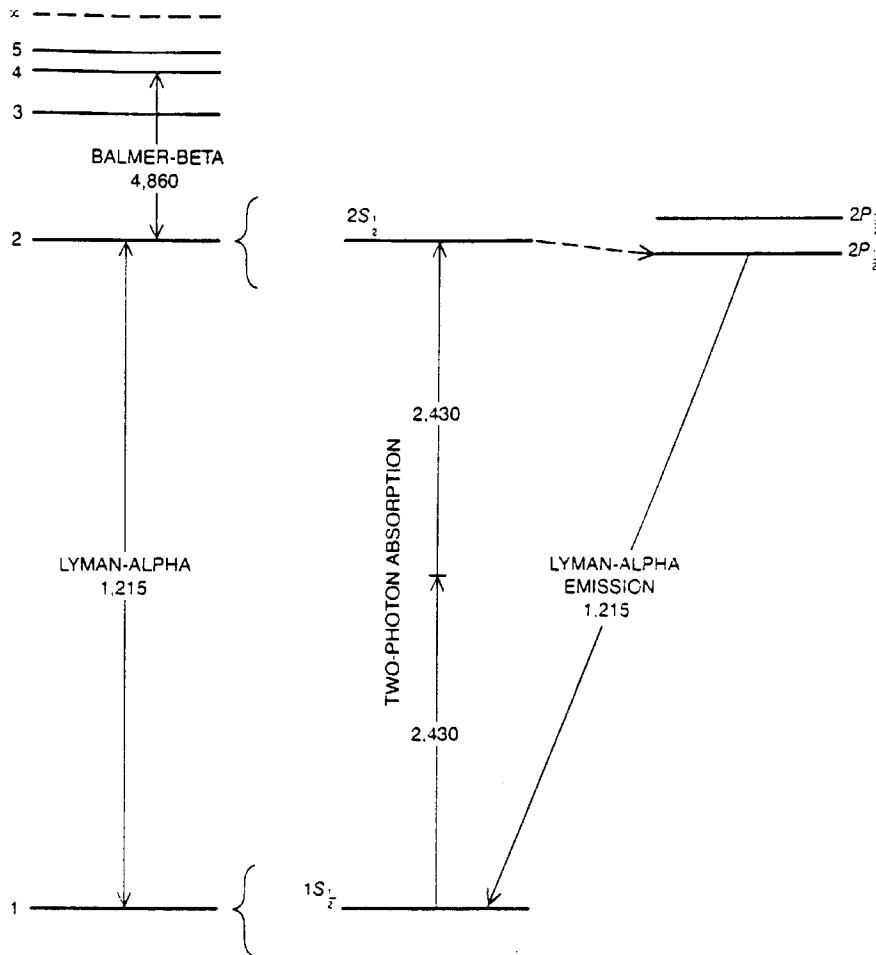

GROUND, OR LOWEST, STATE OF HYDROGEN can be reached only through transitions whose wavelengths are in the vacuum-ultraviolet region of the electromagnetic spectrum; such transitions can be observed more conveniently by two-photon spectroscopy than by any other technique. The Lyman-alpha line, a transition from $n = 1$ to $n = 2$, has a wavelength of 1,215 angstroms, and radiation at twice this wavelength, or 2,430 angstroms, is required for two-photon spectroscopy. Even the latter wavelength is inaccessible to dye lasers and must be generated by doubling the frequency (or halving the wavelength) of a laser tuned to 4,860 angstroms. The frequency doubling is accomplished by a crystal that under intense illumination emits the second harmonic of the incident frequency. The original laser wavelength (4,860 angstroms) happens to correspond closely to the wavelength of the Balmer-beta line. Absorption of two photons in atomic hydrogen stimulates only the $1S_{1/2}$ -to- $2S_{1/2}$ transition. The excited atom is converted by weak encounters with other atoms to a $2P_{1/2}$ state, from which it returns to the ground state by emitting a photon having a wavelength of 1,215 angstroms.

for any systematic errors. In order to measure the absolute position of the line rather than the interval between two lines an accurate reference length was needed. The chosen standard was a helium-neon laser whose frequency was electronically locked to a particular hyperfine component of an absorption line of molecular iodine vapor; this line was also defined by saturation spectroscopy. The wavelength of the stabilized helium-neon laser was known accurately in terms of the international standard of length, which is a spectral line of krypton emitted under defined conditions. The data were evaluated in 1974. The result, $R = 10,973,731.43 \pm .10$ reciprocal meters, was more accurate than the best previous value by a factor of almost 10.

A related method of Doppler-free spectroscopy was introduced in 1976 by Carl Wieman, a graduate student at Stanford working with one of us

(Hänsch). By exploiting the fact that small changes in the polarization of light can be detected more easily than changes in intensity, the technique achieves greatly improved sensitivity. Fewer atoms can be observed at lower laser intensity, thereby avoiding systematic line shifts and line broadening.

Polarization Spectroscopy

As in saturation spectroscopy, the laser light is divided into two beams, one more intense than the other, which traverse the sample in opposite directions. In this case, however, the weaker, probe beam sees the gas sample placed between crossed polarizing filters, so that little light reaches the detector as long as the sample does not change the polarization of the probe. The saturating beam acts on the sample to bring about such changes. It can do so because it is first passed through a quarter-wave plate, a

piece of birefringent material cut and polished so that it gives light a circular polarization. Light is said to be circularly polarized when the electric field rotates (either clockwise or counterclockwise) rather than oscillates in a plane as it does in linearly polarized light.

The probability that an atom will absorb circularly polarized light depends on the orientation of the atom's angular momentum with respect to the rotating field. Initially the orientation of the atoms is random, but the saturating beam depletes the gas of atoms that are oriented so as to absorb light of one circular polarization, leaving an excess of atoms with the opposite sense of rotation. When the probe beam, which is linearly polarized, passes through the same region of gas, the oriented atoms can alter its propagation.

A linearly polarized wave can be regarded as a superposition of two cir-

polarizing filter if the two beams interact with different sets of atoms, and so there is essentially no background signal. Hence real peaks in the spectrum are not easily obscured by noise or by intensity fluctuations of the laser. When the signal is very small, it is often advantageous to uncross the polarizing filters slightly. The detector then registers a finite background signal, which can either increase or decrease, depending on the direction in which the plane of polarization is rotated.

John Goldsmith, a graduate student at Stanford, Erhard Weber, who was at Stanford on leave from the University of Heidelberg, and one of us (Hänsch) have recently obtained an improved spectrum of the Balmer-alpha line by laser polarization spectroscopy. The saturating and probe beams were generated by a low-power, continuous-wave dye laser with a bandwidth of less than

fine splitting should be clearly resolved, but only single peaks are observed. The explanation of this discrepancy is that in each case one of the hyperfine states has a net angular momentum of zero and cannot be polarized. Thus each of the observed peaks is not an unresolved mixture of two transitions but is a single hyperfine component.

The $2S_{1/2}$ -to- $2P_{1/2}$ component was chosen for a new absolute wavelength measurement, again calibrated against the iodine reference line as a standard of length. The new value of the Rydberg constant derived from this measurement is $R = 10,973,731.476 \pm .032$ reciprocal meters. The measurement is almost three times as accurate as the previous one, and it places the Rydberg constant among the most precisely known of all fundamental constants. Only the speed of light and the ratio of the magnetic moments of the electron

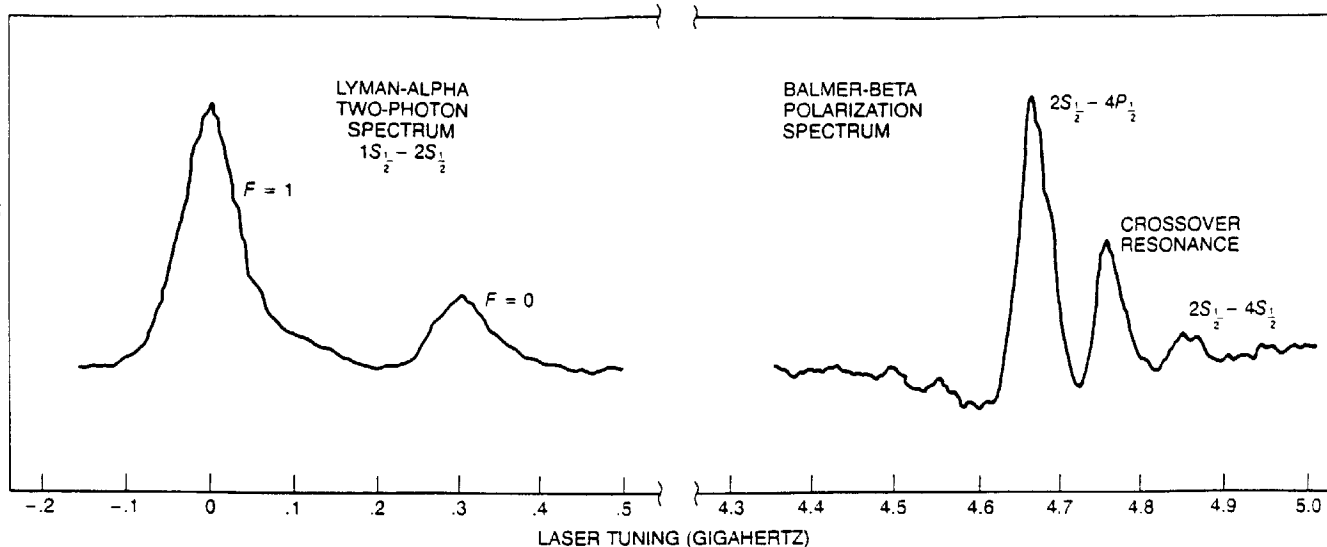

SIMULTANEOUS MEASUREMENT of the $1S_{1/2}$ -to- $2S_{1/2}$ transition and the Balmer-beta line was employed to determine the magnitude of the Lamb shift for the $1S_{1/2}$ state of hydrogen. The Balmer-beta line was measured by polarization spectroscopy at the fundamental wavelength of the laser, 4,860 angstroms. The frequency-doubled output of the same laser was simultaneously employed to record a two-photon spectrum of the $1S_{1/2}$ -to- $2S_{1/2}$ transition

at an effective wavelength of 1,215 angstroms. If the Bohr energy levels were exact, the two transitions would be observed at the same laser tuning, but the splittings of the energy levels introduce a small discrepancy. From the measured difference in the laser tunings for the two lines, the magnitude of the $1S_{1/2}$ Lamb shift was calculated with a precision 50 times greater than that of other measurements. Value for hydrogen was found to be 8.161 ± 29 megahertz.

of a selected atomic transition. At the proper frequency each atom in the gas can simultaneously absorb two photons coming from opposite directions.

Suppose an atom moving along the optical axis in the standing-wave field encounters two photons approaching from opposite directions. One of the photons is Doppler-shifted toward the blue, meaning higher frequencies, but the other photon is shifted toward the red by an equal amount. For a stationary atom both photons have the same energy. In all cases the total energy or frequency of the two absorbed photons is constant, regardless of the velocity of the atom. As long as the laser frequency is detuned slightly from half the transition frequency none of the atoms can absorb the two counterpropagating photons. (There is a small background signal, however, from moving atoms that absorb two photons propagating in the same direction.) When the laser wavelength matches the atomic transition, a sharp increase is observed in the number of excited atoms. The Doppler-free signal is strongly enhanced because all the atoms in the sample can contribute to it rather than just those that happen to be stationary. In this respect the method differs fundamentally from both saturation spectroscopy and polarization spectroscopy, in which a population of atoms that are free of Doppler shifts is selected. In Doppler-free two-photon spectroscopy one Doppler shift is made to compensate for another.

A two-photon transition of particular interest is the transition from the $1S_{1/2}$ state to the $2S_{1/2}$ state. Because the latter state is a very long-lived one the line is expected to be extraordinarily narrow.

Theoretical estimates suggest a natural line width of about one hertz, or less than one part in 10^{15} , which would make the transition one of the narrowest resonances known in any physical system. The $1S_{1/2}$ state is in itself interesting because its Lamb shift is the largest one predicted by quantum electrodynamics. An atom at the energy level $n = 1$ cannot have orbital angular momentum, and so there is no nearby P state from which the magnitude of the shift can be determined. The shift is simply a displacement of the $1S_{1/2}$ energy level from the position it would have in the absence of quantum-electrodynamical effects. The magnitude of the shift can be determined only by an absolute measurement of some spectral component, such as the $1S_{1/2}$ -to- $2S_{1/2}$ transition.

A two-photon excitation of this transition was first observed in 1974 by Siu Au Lee, Wieman and others at Stanford. The Lyman-alpha line has a wavelength of 1,215 angstroms: a photon with half this energy corresponds to a wavelength of 2,430 angstroms, which is still in the ultraviolet and beyond the reach of tunable dye lasers. The Stanford workers therefore employed a dye laser operating at 4,860 angstroms, or twice the required wavelength. The intense light from this source was shined on a crystal that served as a frequency doubler. Because of the high intensity of the applied electromagnetic field the crystal not only reradiated light at the original frequency but also was driven to emit overtones, including the second harmonic, at 2,430 angstroms. About 2 percent of the energy appeared at this wavelength.

The frequency-doubled ultraviolet radiation was reflected by a mirror to

form a standing wave inside a low-pressure gas-discharge tube. Hydrogen atoms that absorbed two photons returned to the ground state by emitting a single, far-ultraviolet photon at a wavelength of 1,215 angstroms. These photons escaped through a window at the side of the chamber and were detected by a photomultiplier.

The $1S_{1/2}$ -to- $2S_{1/2}$ transitions of both hydrogen and deuterium were measured with this system. Each of these lines has a large hyperfine splitting, which is well resolved in the two-photon spectra. Transitions between the two hyperfine states in hydrogen are responsible for the 21-centimeter radiation that is an important signal in radio astronomy. There is also a large splitting between the hydrogen lines and the deuterium lines, caused chiefly by the difference in nuclear mass. This isotope shift was determined to an accuracy 1,000 times better than earlier measurements. A further improvement by a factor of 10 could provide a new value for the important ratio of electron mass to proton mass.

The greatest interest in the $1S_{1/2}$ state is in the determination of the ground-state Lamb shift. In the 1950's Herzberg, who was then at the Yerkes Observatory of the University of Chicago, was able to detect the shift, but he measured its value to a precision of only about 14 percent. Two-photon spectroscopy provided an opportunity for a far more accurate determination.

The most straightforward approach to measuring the Lamb shift would be to determine the absolute wavelength of the $1S_{1/2}$ -to- $2S_{1/2}$ transition, but the value of the Lamb shift calculated from

that wavelength also depends on an assumed value of the Rydberg constant. The Stanford group found a better method, exploiting a peculiar but not accidental coincidence: the fundamental wavelength of the dye laser, namely 4.860 angstroms, nearly coincides with the Balmer-beta line. If Bohr's formula were correct, the correspondence would be exact: the interval from $n = 1$ to $n = 2$ (Lyman-alpha) would be just four times the interval from $n = 2$ to $n = 4$ (Balmer-beta). Actually the levels are split and shifted somewhat by relativistic and quantum-electrodynamical corrections. The corrections for the $n = 2$ and $n = 4$ levels are known with great precision, however, and so a comparison of the two transitions can determine the ground-state Lamb shift.

Three such measurements have been carried out by the Stanford group, the most recent and the most accurate one by Wieman. The Balmer-beta reference line was observed by polarization spectroscopy, while the same laser simultaneously measured the Lyman-alpha line by two-photon spectroscopy. The Balmer-beta spectrum not only resolved the fine-structure components of the line but also revealed the splitting of these components in the weak axial electric field of the gas-discharge tube. In principle the ground-state Lamb shift could be determined by measuring the difference between the Balmer line and the $1S$ -to- $2S$ line and then comparing the result with the predictions of the Dirac theory. Known corrections would be applied to the positions of the $n = 2$ and $n = 4$ levels; any remaining difference would be attributed to the Lamb shift of the $1S$ state. In practice it was not quite as easy as that, because allowance had to be made for possible systematic errors and imprecisions in the apparatus. The result eventually derived was 8.161 ± 29 megahertz. The experiment is still far short of the accuracy of the theoretic

cal calculations, which give a value of $8.149.43 \pm .08$ megahertz, but it represents a significant step beyond Herzberg's earlier measurement.

Higher Resolution

Many formidable obstacles would have to be overcome in order to approach the one-hertz natural line width of the $1S_{1/2}$ -to- $2S_{1/2}$ transition. It would not be enough to further reduce the bandwidth of the laser, because there are several other sources of line broadening. One of them is a second-order Doppler shift, a consequence of the special theory of relativity. An atom that is moving appears to oscillate slower than one at rest, so that the moving atom effectively has a lower resonant frequency no matter what the direction of motion is. The counterpropagating beams of two-photon spectroscopy cannot cancel this shift, which should amount to about 50 kilohertz for hydrogen atoms at room temperature.

Another source of line broadening is the finite transit time of a moving atom in the laser beam. Because a moving atom is exposed to the laser light only briefly, even the light from a continuous-wave laser is perceived by the atom as a pulse, whose short duration limits the potential resolution of the spectrum. In principle both effects could be reduced by slowing the atoms, or in other words by cooling the gas. In this regard it is encouraging that Daniel Kleppner of M.I.T. has recently shown that atomic hydrogen can be cooled to the temperature of liquid helium (4.2 degrees K.) without condensing, even though diatomic hydrogen molecules condense at 20 degrees K. Two of us (Schawlow and Hänsch) have recently pointed out that laser light itself might cool a gas to a low temperature. This may seem paradoxical, since an intense light usually sup-

plies heat, but it must be recalled that laser light, being coherent, represents a state of low entropy, or low disorder. A state of low entropy can be made to yield a low temperature.

Several laboratories are now attempting to apply the technique of two-photon spectroscopy to the $1S_{1/2}$ -to- $2S_{1/2}$ transition of positronium, a hydrogen-like "atom" made up of an electron and its antiparticle, the positron. The properties of this exotic atom are predicted with great precision by quantum electrodynamics, and there is no need to apply corrections for the structure of the nucleus. The experiment is difficult, however, because positronium has a lifetime of only about 140 nanoseconds.

The hydrogen atom has been a focus of attention for almost a century, but the information embodied in this simple system of particles is by no means exhausted. Recent unified field theories, such as those of Steven Weinberg of Harvard University and Abdus Salam of the Imperial College of Science and Technology, predict subtle effects in hydrogen and other atoms that might be observed as small changes in the polarization of emitted or absorbed light. The changes are so small that there is some question of whether they can even be detected, but several groups of investigators are now attempting to measure them accurately enough to test the theories. As the technology of coherent light sources evolves it seems safe to predict that the exploration of the hydrogen spectrum will continue for decades. So far all the recent findings tend to confirm the predictions of theory. It is worth remembering, however, that several major upheavals in 20th-century physics were instigated by the discovery of minute discrepancies between theory and observation in this very spectrum. The hydrogen atom may hold surprises yet to come. On the other hand, perhaps the greatest surprise would be none at all.

The Authors

THEODOR W. HÄNSCH, ARTHUR L. SCHAWLOW and GEORGE W. SERIES have utilized lasers for high-resolution optical studies of simple atoms. Hänsch is professor of physics at Stanford University. A native of West Germany, he was educated at the University of Heidelberg, which gave him his Ph.D. in physics summa cum laude in 1969. The following year he went to Stanford as a NATO Fellow, and in 1972 he joined the faculty. From 1973 to 1975 Hänsch was an Alfred P. Sloan Research Fellow. Schawlow is J. G. Jackson—C. J. Wood Professor of Physics at Stanford. Born in upstate New York, he received his Ph.D. from the University of Toronto in 1949. After two years as a postdoctoral fellow and research associate at Columbia Univer-

sity he became a research physicist at Bell Laboratories. He has been on the Stanford faculty since 1961. He was co-author with Charles H. Townes of the first paper describing the laser. In 1977 Schawlow was awarded the third Marconi International Fellowship, which was presented in Stockholm by the king of Sweden. Series is professor of physics at the University of Reading. He studied at the University of Oxford, where he obtained his Ph.D. in atomic spectroscopy. He then became lecturer in physics at Oxford, moving to Reading in 1969. Series is a Fellow of the Royal Society.

Bibliography

THE SPECTRUM OF ATOMIC HYDROGEN. G. W. Series. Oxford University Press, 1957.

ATOMIC SPECTRA. W. R. Hindmarsh. Pergamon Press, 1967.

OPTICAL RESOLUTION OF THE LAMB SHIFT IN ATOMIC HYDROGEN BY LASER SATURATION SPECTROSCOPY. T. W. Hänsch, I. S. Shahin and A. L. Schawlow in *Nature Physical Science*, Vol. 235, No. 56, pages 63-65; January 24, 1972.

AN EXPERIMENTAL DETERMINATION OF THE RYDBERG CONSTANT. B. P. Kibble, W. R. C. Rowley, R. E. Shawyer and G. W. Series in *Journal of Physics B*, Vol. 6, pages 1079-1089; June, 1973.

HYDROGEN $1S$ - $2S$ ISOTOPE SHIFT AND $1S$ LAMB SHIFT MEASURED BY LASER SPECTROSCOPY. S. A. Lee, R. Wallenstein and T. W. Hänsch in *Physical Review Letters*, Vol. 35, No. 19, pages 1262-1266; November 10, 1975.