

Design and simulation of a Mode converter for the excitation of Quasi-optical Amplifiers

*Toshihisa Kamei, **Chun-Tung Cheung, ***James J. Rosenberg, **David B. Rutledge

*Department of Electrical Engineering, National Defense Academy, 239-8686 Kanagawa Japan

**Department of Electrical Engineering, California Institute of Technology, Pasadena, CA91125

***Department of Engineering, Harvey Mudd College, Claremont, CA91711

I. Introduction

Quasi-optical grid amplifiers, which occupy a cross-sectional dimension much greater than $\lambda/2$, provide a solution for efficiently combining the power of hundreds of solid states devices [1]. In order to excite quasi-optical amplifier efficiently, a uniform transverse electromagnetic (TEM) field distribution at input and output has to be applied. These arrays utilize direct coupling to fields propagating in open space, guided by lenses and antennas. Recently, a new waveguide packaging technique has been applied to achieve a compact amplifier module at millimeter-wave frequencies [2,3]. These amplifiers were designed to produce several Watts of power and became drop-in replacements for systems using conventional tube amplifiers. The waveguide packages contain tapered transitions from single mode to over-moded waveguide in order to couple TE₁₀ mode in the standard waveguide to the amplifier in the over-moded waveguide section. In this arrangement, the amplifier cells at the center saturate before the edge cells can be adequately pumped due to the transverse E-field non-uniformity of the TE₁₀ mode. In addition, individual unit cell in the array will see different source and load impedances depending on its location in the array. The amplitude and phase errors along with impedance mismatches at the input and output make most of the edge cells ineffective resulting in a degradation of up to 6dB in maximum output power. Thus, packaging improvements to present an environment similar to that of free-

space wave propagation are critical to obtain the maximum amplifier performance. Previously, researchers have studied various approaches to obtain TEM-mode such as hard horn feeding [4] and photonic crystal walls [5]. It is convenient if we can feed the amplifier from standard waveguide. However one must have a means of converting between a standard waveguide and a large over-moded waveguide. This paper presents simulations of structures aimed at distributing the power from a standard TE₁₀ waveguide to an over-moded waveguide.

II. Design of a Mode converter

Our goal is to design a waveguide converter for 35GHz that changes in dimension from a standard WR-28 waveguide (7.11mm×3.56mm) to an over-moded waveguide (13mm×10mm) in a controlled fashion such that a proper amount of TE₃₀ mode is excited to achieve flat field distribution. Figure 1 shows the structure of the mode converter.

The H-plane transition is composed of two sections of rectangular waveguides that increase the guide width from standard width to 1.5λ in two steps. The sizes of steps and their placements along the direction of propagation are critical in order to obtain uniform power and phase distributions. The overall length of the H-plane transition is 0.75λ . The field magnitude distribution across the over-moded aperture at equal phase plane is uniform to within 3dB across 75% of its width, and within 6dB across 85% of its width. Based on

these results, the step is then changed to a tapered shape. Figure 2 is an example of the simulation result. The simulation was done with Ansoft's High Frequency Structure Simulator (HFSS).

The E-plane transition is, in a strict sense, a power splitting structure which couples the energy input from a standard TE_{10} waveguide into four TE_{10} waveguides through specially designed irises. The inductive irises adjust the phase by making use of the difference in phase velocity for waveguides of different width. As a result, the field distribution in output waveguides should be equal in phase and magnitude at the output reference plane. They are then combined together to form the required vertical transition by terminating adjacent waveguide walls a quarter wavelength away from the coupling holes.

Finally the E- and H-plane transitions are cascaded to expand in both height and width. H-plane transition must be installed after E-plane transition but not vice versa because of the requirement of only exciting TE_{30} mode. The simulation of the combined structure was examined and it was confirmed that the designed E-plane transition suppressed undesired TM modes and the H-plane transition was able to excite TE_{30} mode to form flattened field distribution at specific output waveguide planes.

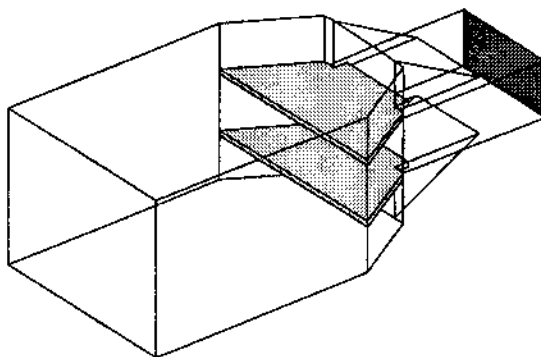

fig.1 Proposed mode converter

III. Measurements

The electric field distribution inside

the 35GHz waveguide was measured using a semi-rigid coaxial cable probe with a 1.19mm outside diameter. The inner conductor of the coaxial cable of 0.287mm in diameter extended 0.508mm into the waveguide interior. It was designed to have coupling coefficient of -20dB and -30dB in the standard waveguide and over-moded waveguide respectively. The accuracy of the probe system was verified by measuring the conventional TE_{10} mode electric field distribution of a standard waveguide session. An H-plane waveguide taper was also fabricated and the field distribution at the uniform phase plane was measured. Figure 3 shows E-field measurements of standard waveguide and the H-plane tapered transition.

The E-plane and H-plane combined transition mode converter was fabricated. The E-field distribution was measured and shown in Figure 4. Figure 5 shows the return loss measured and simulated respectively.

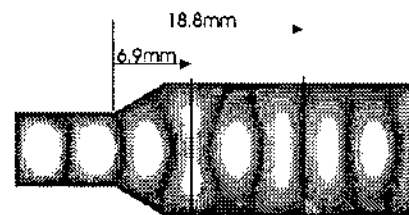

fig.2 Simulation result

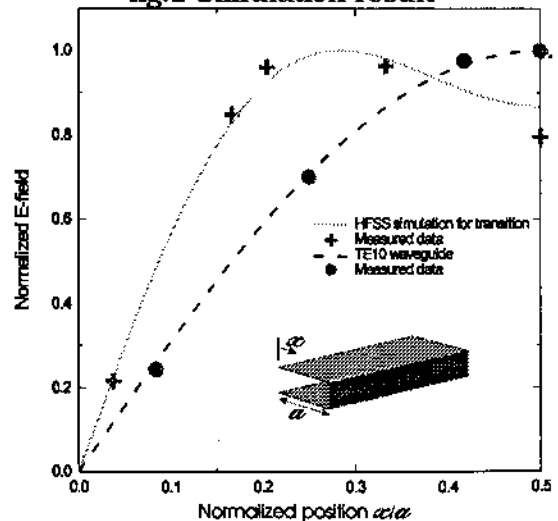

fig.3 Experimental result (H-plane)

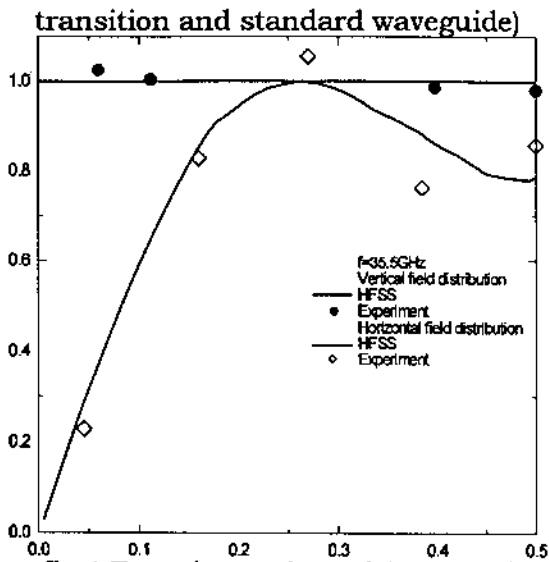

fig.4 Experimental result (proposed mode converter)

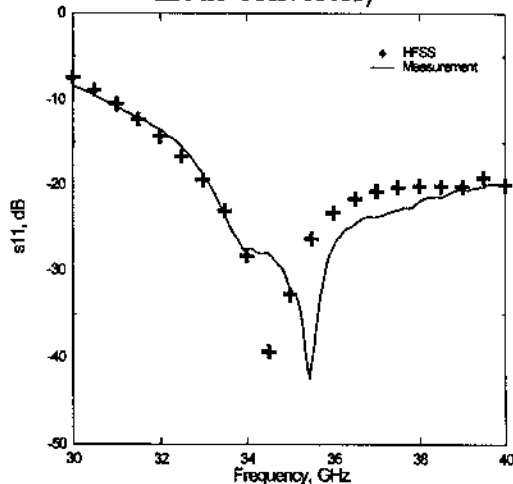

fig.5 The characteristics of Return Loss

IV. Conclusion

In this paper, an analysis of mode converter for the excitation of the quasi-optical amplifiers was presented. The analysis is based on the finite element method and results in a generalized S-matrix for the new structure. The simulation results show a good agreement with measurements at millimeter-wave frequencies.

V. Acknowledgements

The authors are grateful to the Caltech Quasi-Optical Power Combining MURI for support.

References

- [1] M.Kim, J. Rosenberg, R.P. Smith, R.M. Weikle, J.B. Hacker, M.P. DeLisio, and D. B. Rutledge, "A grid amplifier," *IEEE Microwave Guided Lett.*, vol.1, pp.322-324, Nov.1991.
- [2] E.A.Sovero, et al., "A Ka-band Monolithic Quasi-Optic Amplifier," 1998 *IEEE MTT-S*, pp.13-27.
- [3] Y.Kwon, et al., "A 44GHz Monolithic Waveguide Plane wave Amplifier with Improve Unit Cell Design," *IEEE Trans. Microwave Theory Tech.*, vol.46, pp.1237-1241, September 1998.
- [4] M.A.Ali, S.Ortiz, T.Ivanov, A. Montazawi, "Analysis and Measurement of Hard Horn Feeds for the Excitation of Quasi-Optical Amplifiers," 1998 *IEEE MTT-S*, pp.1913-1921.
- [5] M.Kim, J.B. Hacker, A.L. Sailor, S.Kim, D. Sienpiper, and J.A. Higgins, "A Rectangular TEM Waveguide with Photonic Crystal Walls For Excitation of Quasi-Optical Amplifiers," 1999 *IEEE MTT S*, pp543-546.