

Industrial Class-E Power Amplifiers with Low-Cost Power MOSFETs and Sine-Wave Drive

John F. Davis and David B. Rutledge

Division of Engineering and Applied Science
California Institute of Technology
Pasadena, CA 91125

Abstract—We have developed a 200-W Class-E amplifier for industrial applications. The amplifier operates at 13.56 MHz and uses the International Rectifier IRFP440 Power MOSFET, which costs only \$4. This transistor is intended for use in switching power supplies, but we have found that it works well at RF. A drive level of 10 W gives a drain efficiency of 91% and an overall efficiency of 87%. All harmonic levels are more than 40 dB below the carrier. We have also developed a simple switched-based SPICE model that accurately predicts the voltage waveforms, efficiency, and harmonic levels.

Introduction

There are many applications of RF power amplifiers. They can be used in transmitters for communications, in plasma Chemical Vapor Deposition (CVD) for semiconductor processing and in Magnetic Resonance Imaging (MRI). Conventional RF power amplifiers use either vacuum tubes or RF MOSFETs. The vacuum tubes need kilovolt power supplies and the RF MOSFETs are expensive. For example, a 1-kW MRF154 MOSFET pair from Motorola, costs \$924 each. The approach we have used is to incorporate an inexpensive power MOSFET, the IRFP440, into a Class-E configuration for 13.56-MHz industrial power. This circuit is a further development of a 7-MHz amplifier intended for amateurs [1].

The Class-E amplifier, investigated by Gerald Ewing in 1964 [2] and developed and patented by Nathan and Alan Sokal in 1975 [3], is a switching-mode amplifier. The transistor operates as a switch, half the time completely *on* and the other half completely *off*. When the transistor turns off, the current flows into the resonant load network, and there is a transient voltage that rises and falls. With a properly designed load network, the voltage returns to zero smoothly with zero slope. When the transistor turns on, current rises smoothly until it switches off again. The transistor switches on when both the voltage and current are small, thus keeping losses low. Finally, the resonant load network limits the Class-E amplifier to single-band operation.

Class-E amplifiers are extremely efficient, with about 90% of the DC input power converted to RF output power. To see this, we can derive an expression between the maximum output power P_o , the maximum dissipated power P_d and the efficiency η . Write P_o in terms of the input power P_i as

$$P_o = \eta P_i$$

and the dissipated power P_d as

$$P_d = (1 - \eta)P_i$$

Finally, divide the two formulas to get

$$P_o/P_d = \eta/(1 - \eta)$$

Figure 1 shows the plot of this relation versus efficiency with the typical efficiencies for the classes of amplifiers shown. Note that you can get more power out of the same transistor if you are limited by thermal dissipation. A Class-E amplifier operating at an efficiency of 90% can produce twenty times as much power as a 30% efficient Class-A amplifier at the same dissipation level.

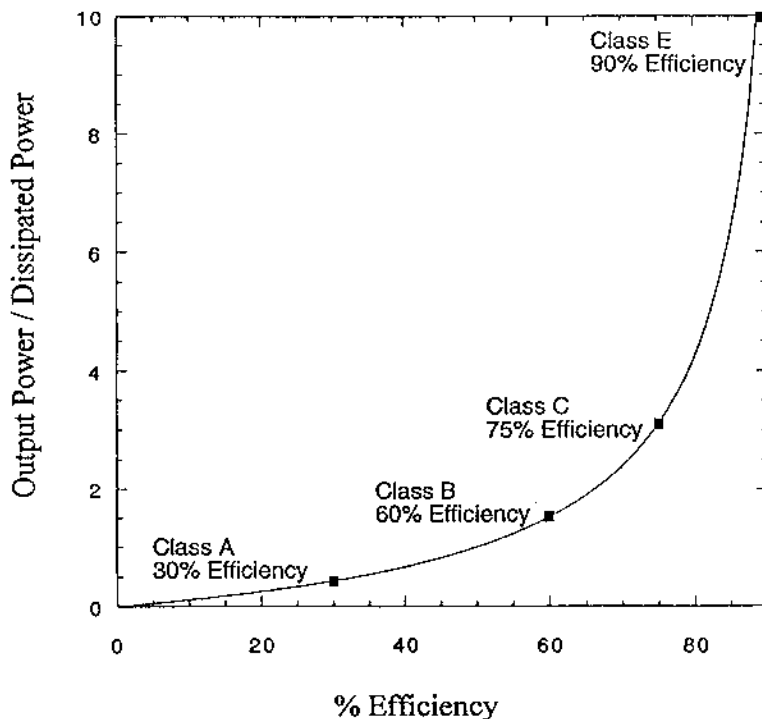

Figure 1. Output power versus efficiency. High efficiency allows much greater output power.

The 200 W, 13.56-MHz Power Amplifier

The amplifier circuit is shown in Figure 2. The AC input, passes through the isolation transformer and the fullwave rectifier. The rectified signal passes through the input filter, the 40- μH choke (RFC), and the bypass capacitor (C_b). The RF choke converts the 0 to 100-Vdc input from the power supply to a current source, and the bypass capacitor helps keep RF energy out of the power supply. The series inductor (L_s) and capacitor (C_s) form the resonant network that produces the rising and falling voltage waveform needed for the Class-E amplifier. Output power is determined by the supply voltage and the value of the series inductance (L_s). A supply voltage of 100 V gives an output power of 200 W. The tank circuit at the load (L_I and C_I) is a trap for the second harmonic. Without the trap, the second harmonic is at the -26-dB level. With the trap, all harmonics are more than 40 dB below the carrier. In addition, (L_I and C_I) transform the 50- Ω load to around 10 Ω , the appropriate range for a Class-E amplifier.

The impedance of the gate is small, only about 3 Ω and it is primarily resistive. The transformer (T) reduces the 50- Ω impedance of the drive circuit to about 2 Ω to match the low resistance of the gate. This gate transformer also sets the DC bias to zero volts and insures the transistor is "off" when it is not driven, as this is far below the threshold voltage of about 4 V.

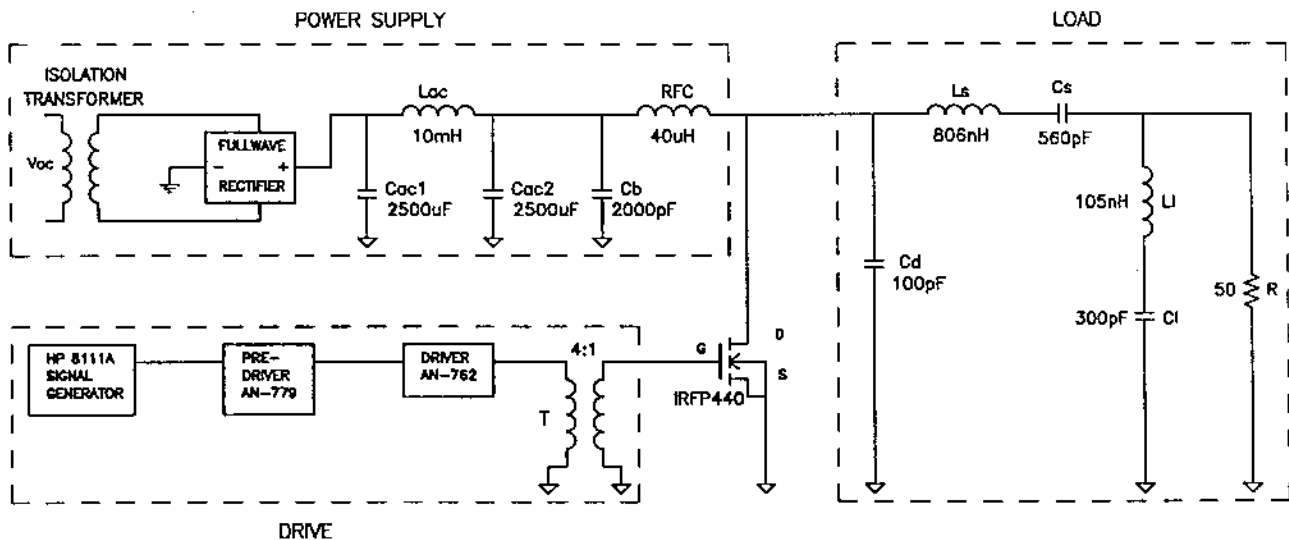

Figure 2. 13.56-MHz Class-E amplifier circuit. The IRFP440 Power MOSFET acts as a switch that opens and closes at the RF frequency. The capacitors are all silver micas with a 1000-V rating.

Tuneup and Power Calibration

When initially powering the amplifier, two adjustments are made. First, the SWR is checked with full RF input. If it cannot be brought down below 2:1, a turn is added or subtracted from the gate transformer. With a power meter and a 50- Ω dummy load on the RF output, the output power is set by stretching or squeezing (Ls). This, however, is done before the dc input voltage is applied. Stretching the coil reduces the inductance and increases the output power. However, the input power will also increase and lower the efficiency. Squeezing reduces the output power and usually increases the efficiency. Thus, Ls is adjusted to optimize the trade-off between output power and efficiency. It should be pointed out, that too much inductance can cause severe ringing in the gate and drain waveforms. To achieve RF output power of 200 W, heat removal from the MOSFET is facilitated by attaching it to a water-cooled, copper, heat sink instead of a conventional metal heat sink. The gate and drain waveforms are shown in Figure 3.

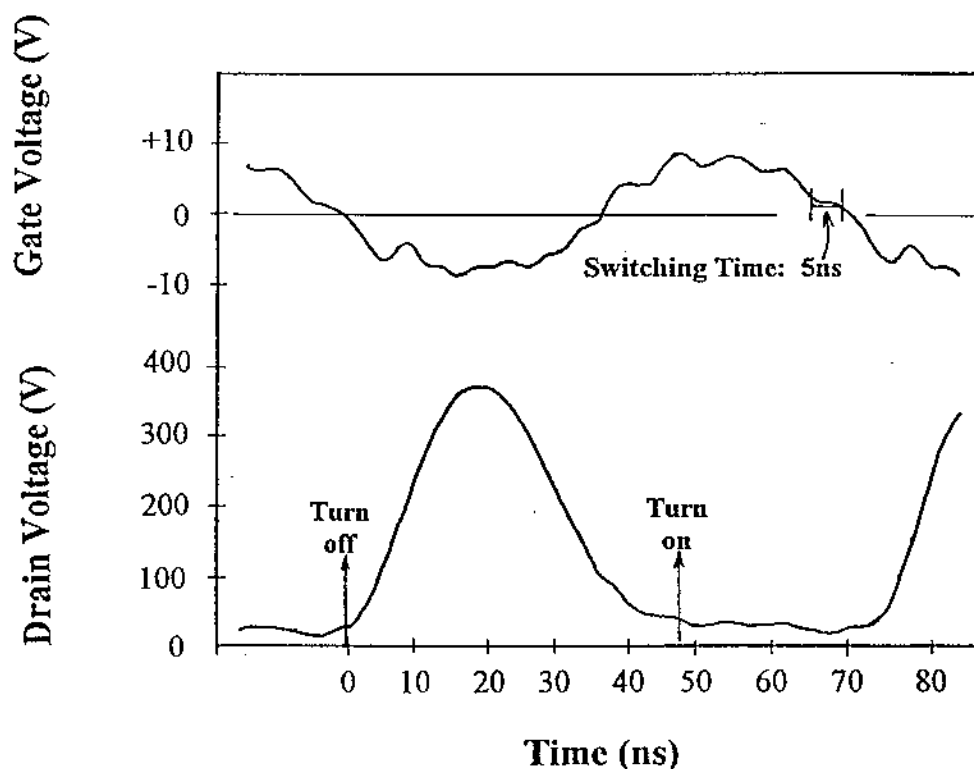

Figure 3. Oscilloscope trace of the measured gate and drain voltage for the 200-W amplifier with 10-W drive. The DC supply is 100 V and the input SWR is 1.8:1. The peak gate voltage is 9 V, and the peak drain voltage is 350 V, safely within the manufacturer's ratings of 20 V and 500 V.

Class-E amplifiers have high efficiency and it is important to obtain accurate readings of the output power to calculate the circuit losses accurately. A Bird wattmeter with an accuracy of ± 13 W was used to measure the output power. To improve this accuracy, the wattmeter was calibrated using a thermal method developed by Joyce Wong [4].

The calibration procedure is as follows: a thermocouple is attached to the output end of the $50\text{-}\Omega$ load. It is placed at this location to account for the delay in temperature rise between the input and output ends. Next, DC power is applied to the load at a level that is close to the RF power used for the amplifier: 175 W. The temperature is measured at every minute during a 30-minute “on” period and for another interval of 30-minutes when the power is turned off. We get a rising curve of temperature, with a peak that occurs a minute or two after the power is turned off. This peak is characteristic of the amount of power applied to the load and the time we applied it.

After letting the load cool back to room temperature, subsequent measurements at 200 W_{dc} and 225 W_{dc} are made. Finally, the amplifier is run with a 200-W nominal reading on the Bird wattmeter. The thermocouple does not function when RF power is on, thus the temperature of the load is recorded starting at the 30th minute when the amplifier is turned off. Figure 4 shows a plot of thermal measurements where the load temperatures peaked at the 32nd minute.

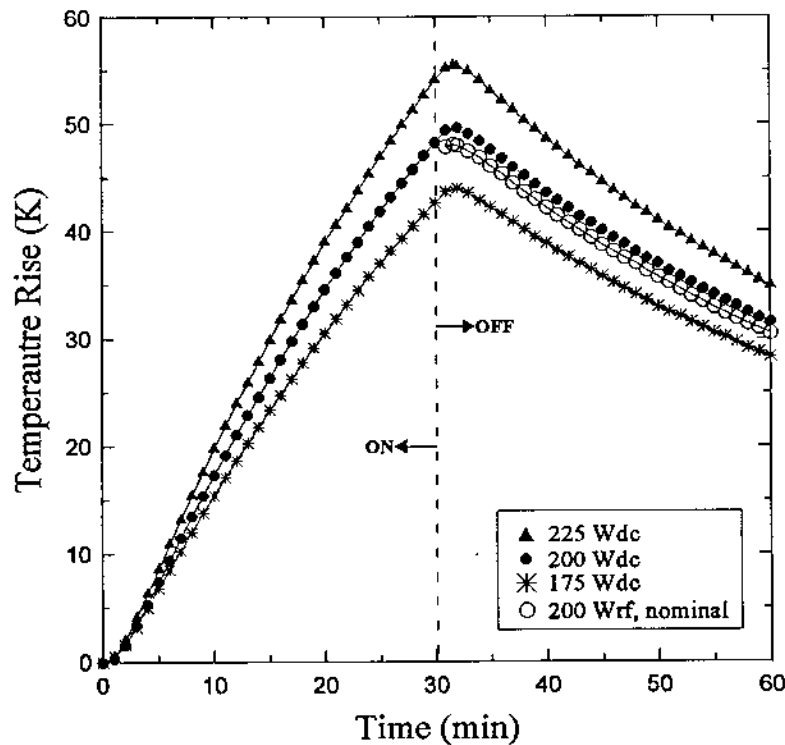

Figure 4. Plot of load temperature vs. time.

Figure 5 is a plot of power versus the peak temperature values. By using the load temperature at the 200-W nominal RF power, we can interpolate to determine the actual RF wattmeter reading. From the plot, the wattmeter reads 3.4% too high. By subtracting this from the nominal RF power we get the correct load power of 193.5 W. To compensate for this overestimation, a 5-ft section of coaxial cable is added in front of the Bird meter. Adding this to the load power results in the correct amplifier output power of 198.6 W.

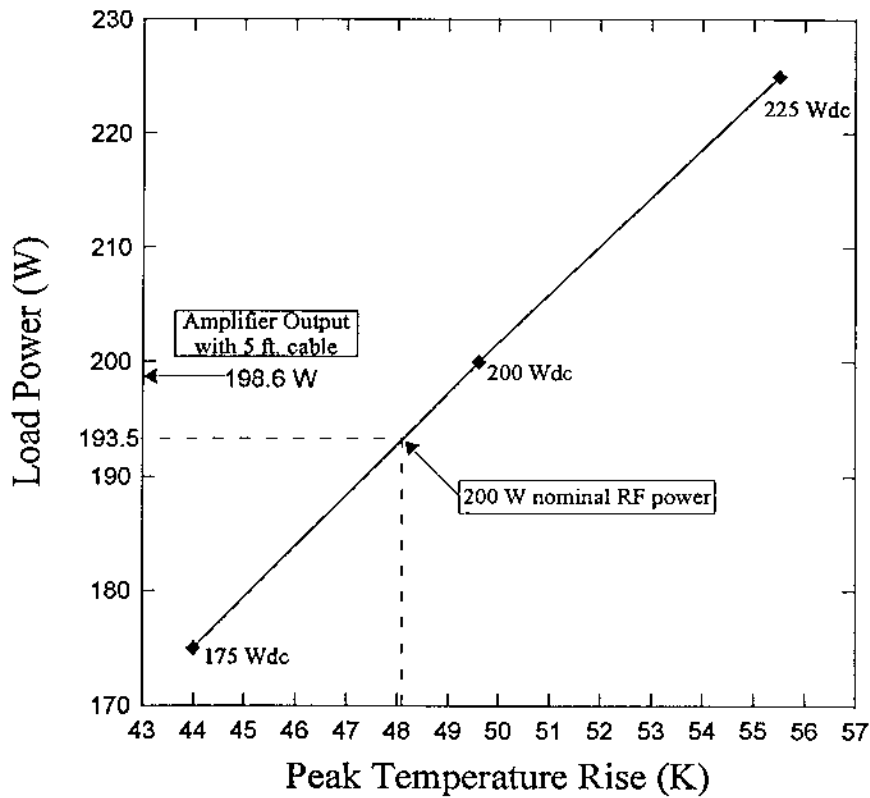
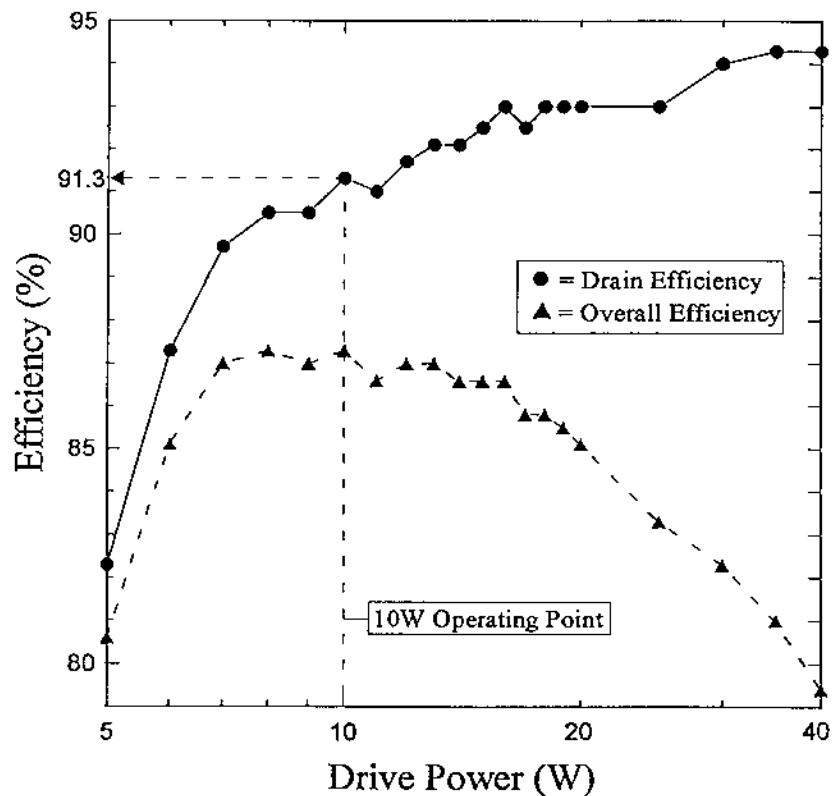

Figure 5. Load power versus peak temperature rise of 50- Ω load.

Experimental Results

The efficiency of the 200-W amplifier as a function of drive power is examined in Figure 6. The drain efficiency is above 91% for input powers above 10 W. However, large drive levels increase the heat dissipated in the amplifier. To take this into account, we have plotted the *overall efficiency*, or ratio of the RF output power to the total input power (DC plus RF). Overall Efficiency is a better indicator as to how hot the transistor is going to get.



Definition:

$$\text{Drain Efficiency} = \frac{P_{\text{out}}}{P_{\text{DC}}}$$

$$\text{Overall Efficiency} = \frac{P_{\text{out}}}{(P_{\text{DC}} + P_{\text{Drive}})}$$

Figure 6. Drain and overall efficiency versus drive power. We recommend keeping the drive power below 15 W to minimize heat dissipation in the MOSFET.

Another performance measurement examines how the drain efficiency varies with output power. Figure 7 shows that high efficiency is maintained over a wide range of powers, 100 W to 250 W. Note the calibrated data points.

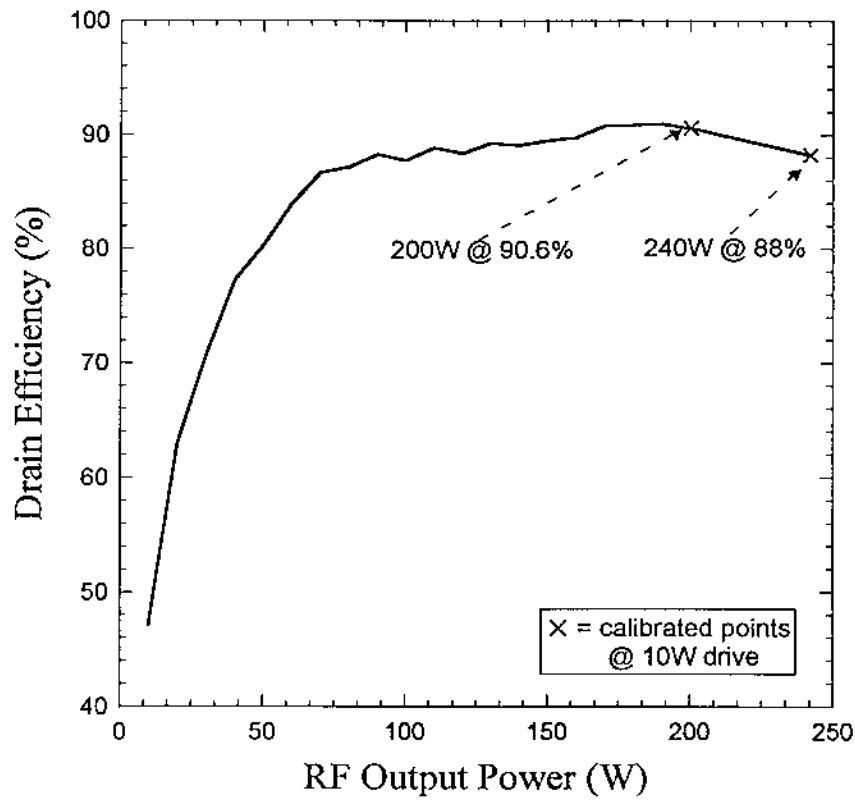
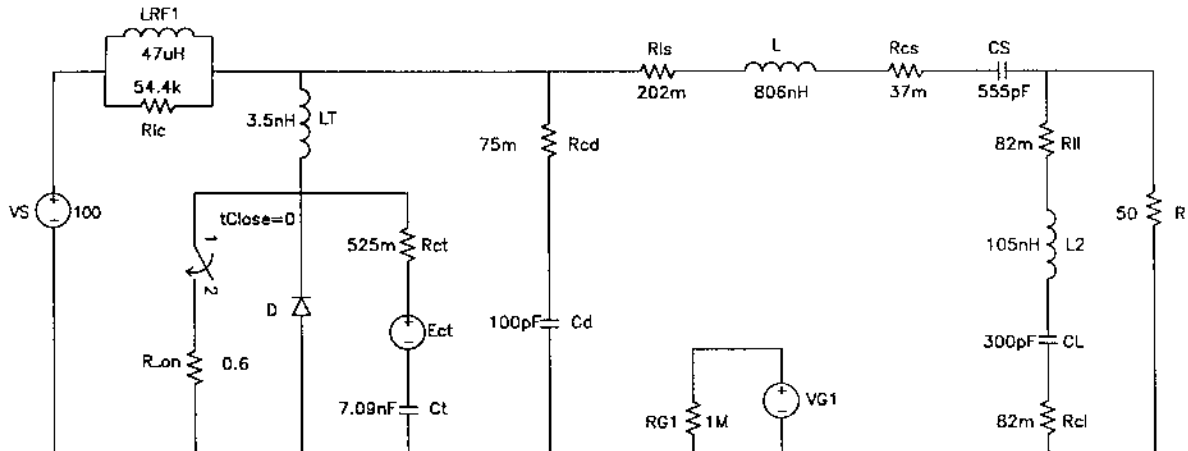

Figure 7. Drain efficiency versus output power.

Computer Simulation

The schematic in Figure 8 represents the Class-E circuit implemented in SPICE. All components in the model are measured using the Hewlett Packard HP4194A Impedance Analyzer. The transistor is modeled as a switch with a linear capacitor (C_t) and a nonlinear dependent voltage source (E_{ct}) to model the square-root behavior of the drain-source capacitance. A performance comparison between the actual data and the simulation is in the table below.



	<u>Experiment</u>	<u>SPICE Model</u>
RF Output Power	200W	203W
DC Input Power	219W	222W
Drain Efficiency	91%	92%
Peak Drain Voltage	350V	360V

Figure 8. 13.56-MHz Class-E SPICE model and performance table. All component values used in the model are measured.

The switch current and drain voltage waveforms resulting from the simulation are shown in Figure 9. The measured drain voltage is drawn on top of the SPICE result for comparison.

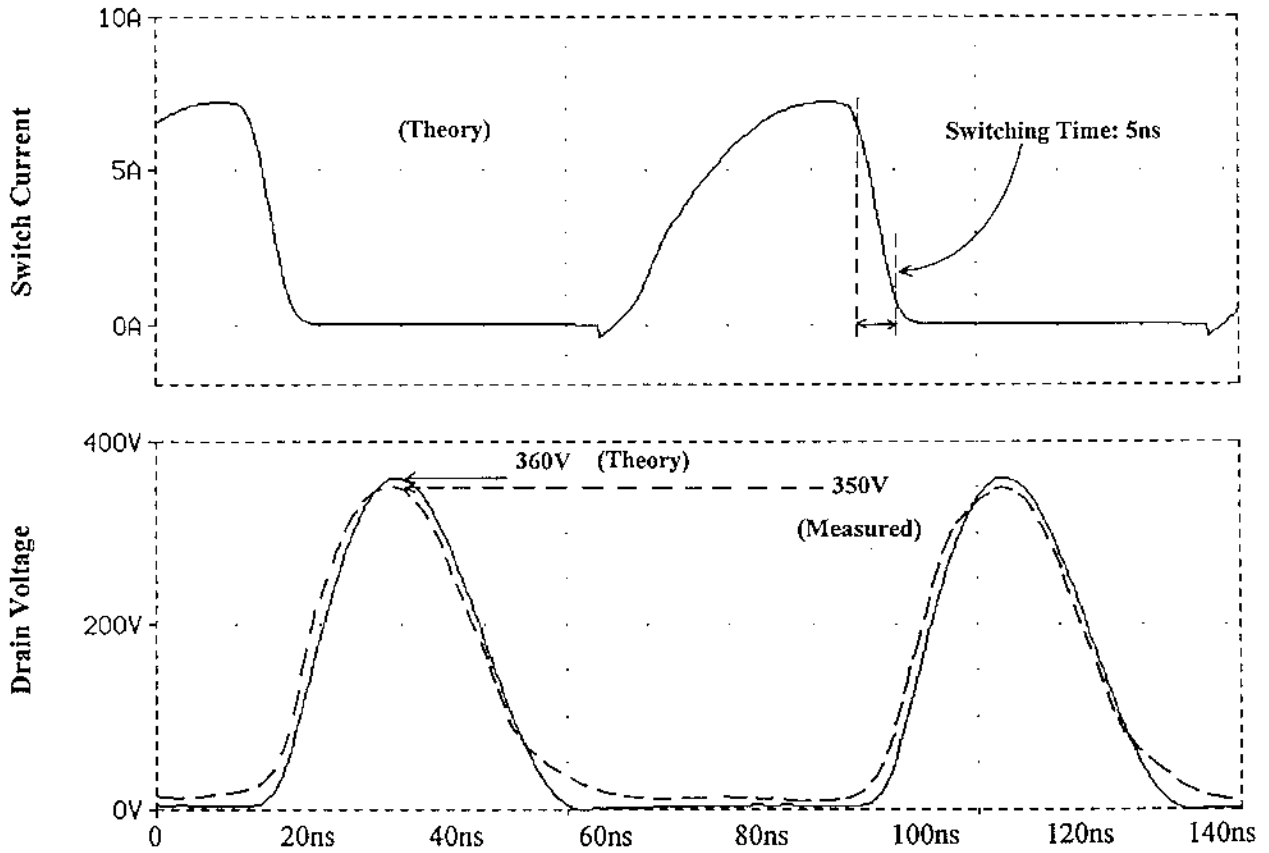

Figure 9. Simulated switch current and voltage. The experimental switch voltage is also shown.

Another aspect of the SPICE simulation involved calculating the RF harmonic spectrum and comparing it with the experimental data. Figure 10 shows the results of this comparison. The first few harmonics (1 through 7) do well in the prediction. However, there is a problem: strong harmonic components exist at 108 MHz and 230 MHz that are not predicted by the SPICE simulation.

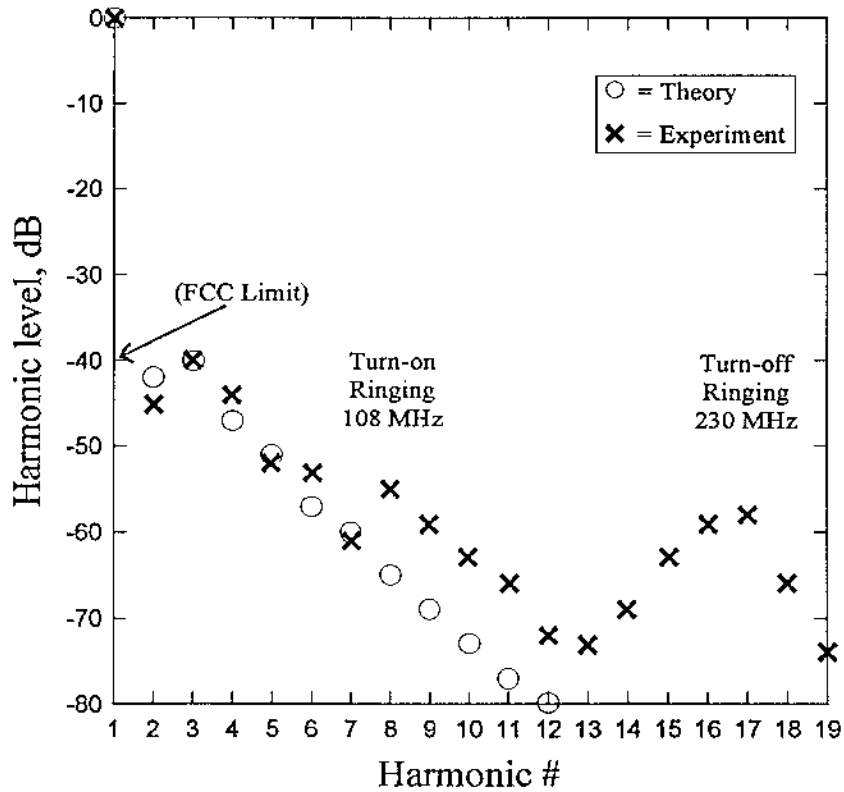
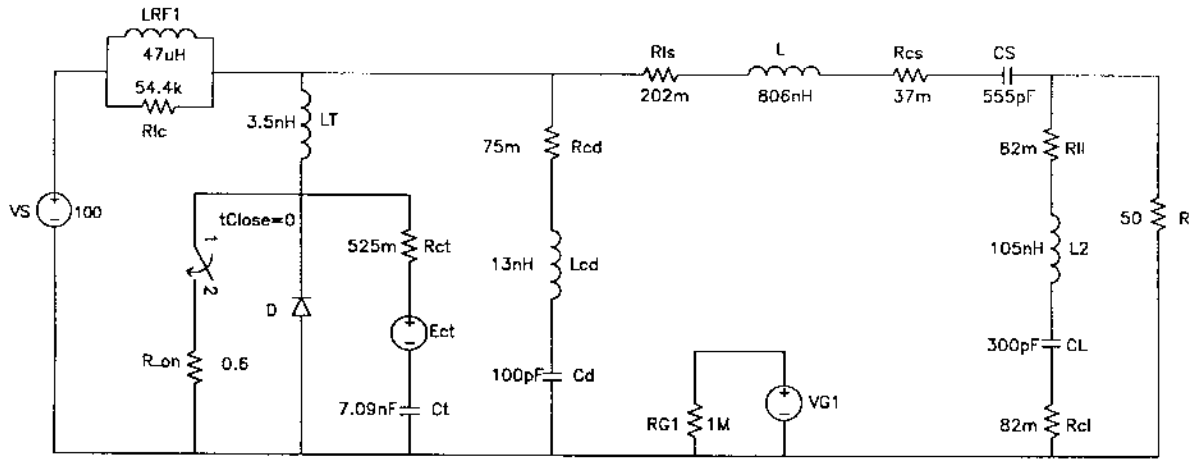
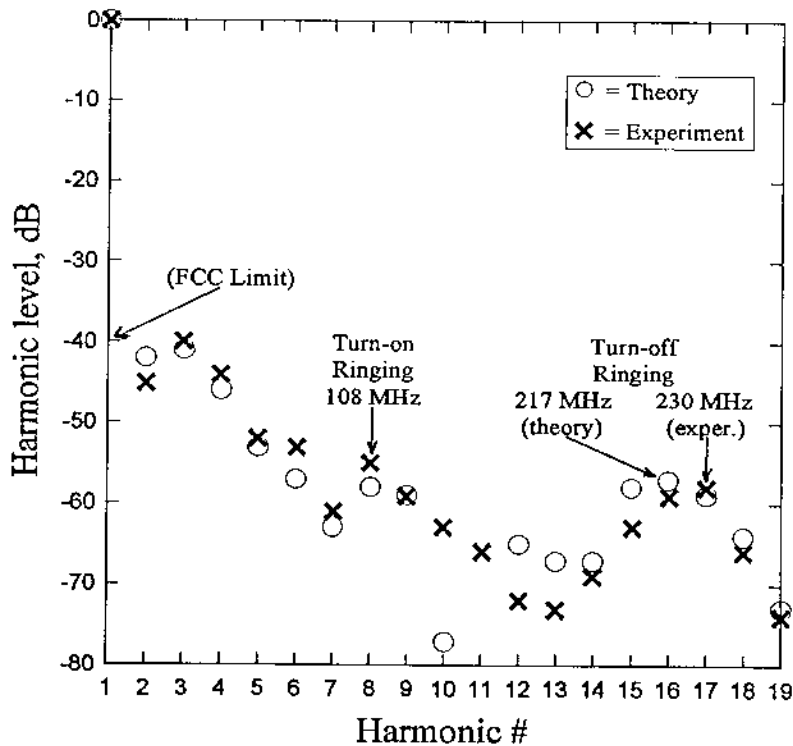

Figure 10. Initial RF output spectrum.

In order to predict both of these frequencies, one component was added to the model: the measured parasitic inductance (L_{cd}) of the drain capacitor (C_d). The revised schematic and the new spectrum are shown in Figure 11.



(a)



(b)

Figure 11. Incorporating L_{cd} (a) and the improvement in the comparison between theory and experiment (b).

The final SPICE simulation involved the calculation of component losses. Knowing where the losses occur in the circuit will aid in determining which elements get hot and ultimately fail. The table below shows these results.

Inductors: L_c	= 0.3W
L_s	= 3.1W
L_l	= <u>0.9W</u>
Total Inductor Loss	4.3W

Capacitors: C_b	= 0.2W
C_s (pair)	= 0.6W
C_l (pair)	= <u>0.9W</u>
Total Capacitor Loss	1.7W

Calculated maximum temperature rise: 30°C (67°C/W)
 (manufacturer's limit: 125°C)

Transistor Losses

Off-Resistance	= 0.6W
On-Resistance	= 7.8W
Turn-off Loss	= 4.1W
Drive Power	= <u>10 W</u>
Total Transistor Loss	22.5W

Total Loss = 28.5W

Switch loss - Turn-off loss = On-resistance loss
--

Figure 12. Calculated component losses. Measured values are used in the simulation.

Conclusion

We have shown that inexpensive power MOSFETs can be used to make industrial RF power amplifiers. Using the IRFP440 and 10 W of drive power, 200 W of output power is obtained with a drain efficiency of 91%. Water cooling was necessary for this development to aid in heat removal from the transistor. A performance summary table is shown in Figure 12.

• V_{ac}	87 V
• V_{dc}	100 V
• I_{dc}	2.2 A
• Calculated $I_{D_{rms}}$ (manufacturer's limit: 8.8 A)	5.1 A
• Drain Efficiency	91 %
• Calculated transistor loss	22.5 W
• Calculated Junction Temperature (0.8K/W, 22°C sink)	40°C
• Calculated inductor and capacitor loss	6 W
• Gate Drive (VSWR 1.8:1)	10 W
• Harmonics	41dB (3rd harmonic)

Figure 13. 200-W Class-E amplifier operation results.

Acknowledgements

The authors appreciate the help and support received from the ETO Corporation and the Army Research Office.

References

- [1] E. Lau, K.-W. Chiu, J. Qin, J. F. Davis, K. Potter, D. B. Rutledge, "High-Efficiency, Class-E Power Amplifiers," *Part 1, QST*, pp. 39–42, May 1997; *Part 2, QST*, pp. 39–42, June 1997.
- [2] G. D. Ewing, "High-Efficiency Radio-Frequency Power Amplifiers," Ph.D. Dissertation. Oregon State University, Corvallis, Oregon, 1964.
- [3] N. O. Sokal and A. D. Sokal, "Class E - A new class of high-efficiency tuned single-ended switching power amplifiers," *IEEE Journal of Solid-State Circuits*, Vol. SC-10, pp. 168–176, June 1975.
- [4] J. Wong, "A 300-W Solid-State Class E Amplifier for Amateur Communications," Bachelor's Thesis. California Institute of Technology, Pasadena, CA, 1995.