

Quasi-Optical and Spatial Power Combining

Michael P. DeLisio, *Senior Member, IEEE*, and Robert A. York, *Senior Member, IEEE*

Invited Paper

Abstract—Quasi-optical power-combining techniques have been developed to address fundamental limitations in solid-state devices and circuits. These techniques have been applied to oscillators, amplifiers, frequency-conversion components, and control circuits. This paper surveys progress in the development of quasi-optical array systems operating in the microwave and millimeter-wave regime, focusing primarily on the progress in power amplifiers.

Index Terms—Active arrays, amplifiers, power combining, quasi-optics, spatial power combining.

I. INTRODUCTION AND MOTIVATION

AS THE operating frequency of semiconductor solid-state devices increases well into the millimeter-wave region, the size of the devices and, hence, their power-handling capability, are reduced. In order to exploit the advantages of a solid-state technology for high power levels at millimeter-wave frequencies, multiple solid-state components must be combined.

Techniques for device- and circuit-level combining are extensively reviewed in [1]–[3]. Single-chip monolithic microwave integrated circuit (MMIC) amplifiers typically combine the outputs of the transistors directly in parallel or with corporate binary Wilkinson power combiners. A survey of current state-of-the-art is impressive: researchers at TRW have reported 427 mW at 95 GHz from a single-chip amplifier [4], and have achieved 1 W at 62 GHz [5] with a two-channel amplifier and an off-chip combining network. Commercially available single-chip amplifiers include the TriQuint [6], Raytheon [7], and Sanders [8] 2-W *Ka*-band amplifiers. Higher power levels can be achieved using multichip modules with off-chip microstrip or waveguide combining networks, with the associated drawback of increased assembly. Researchers at TRW have reported a 2.4-W *W*-band amplifier by combining eight chips in a waveguide structure [9]; a group at Northrop Grumman reported a 1-W *W*-band module combining 16 chips [10]. At *Ka*-band, researchers from Motorola have reported an eight-way module that generates 31 W [11].

These results approach fundamental limits in device power density and combining efficiency. Combining large numbers of

amplifiers on-chip eventually becomes impractical, as it results in most of the semiconductor area being devoted to the passive matching and combining circuitry; furthermore, losses in the semiconductor transmission lines are relatively high, leading to a reduction in combining efficiency. These factors are discussed in [12] to quantify limits on combining efficiency. In order to realize solid-state components with higher power and efficiency, combining techniques must be used that can integrate large numbers of devices with minimal signal distribution and combining losses, while maintaining desired amplitude and phase relationships. Spatial or quasi-optical techniques provide a possible solution.

Spatial or quasi-optical power combining provides enhanced RF efficiency by coupling the active components to large-diameter guided beams or waveguide modes, rather than the planar transmission lines used in circuit-combining structures. Using a large beam cross section allows many devices to be integrated in a single stage of combining. Since all of the elements are operating in parallel, the loss is roughly independent of the number of amplifiers. Ohmic losses in these systems are minimal since the energy is distributed and combined in air via low-loss waveguides or Gaussian beams. Most of the losses in these systems are associated with coupling from the active devices to the propagating beam and/or coupling to a power collection port, both of which can be minimized through careful design.

Note that the terms “spatial” and “quasi-optical” are often used interchangeably. To further confuse the issue, some of the reported systems closely resemble ordinary antenna arrays, or are housed in closed metallic waveguide. Though there is no formal definition, the term quasi-optical is usually understood to mean an electronic system that employs high-order beam-guiding components (e.g., Gaussian beams defined by lenses and/or shaped mirrors) for signal distribution and collection. It could be argued that any antenna array, particular if feeding a large lens or shaped reflector is, therefore, quasi-optical. A useful distinction is that classical antenna arrays or spatial combiners use circuit-based feed networks to insure mutual coherence between the array elements, whereas quasi-optical systems employ “optical” methods for this purpose. However, since many of the so-called quasi-optical systems are often packaged in a metallic waveguide enclosure, it is probably best to consider the term “quasi-optical” as indicative of a qualitative methodology based on multidimensional wave interference and diffraction that is distinct from one-dimensional lumped-circuit or transmission-line systems.

Manuscript received May 22, 2001. This work was supported by the Army Research Office and by the Defense Advanced Research Projects Agency.

M. P. DeLisio is with Wavestream Wireless Technologies, West Covina, CA 21791 USA.

R. A. York is with the Electrical and Computer Engineering Department, University of California at Santa Barbara, Santa Barbara CA 93106 USA.

Publisher Item Identifier S 0018-9480(02)01959-2.

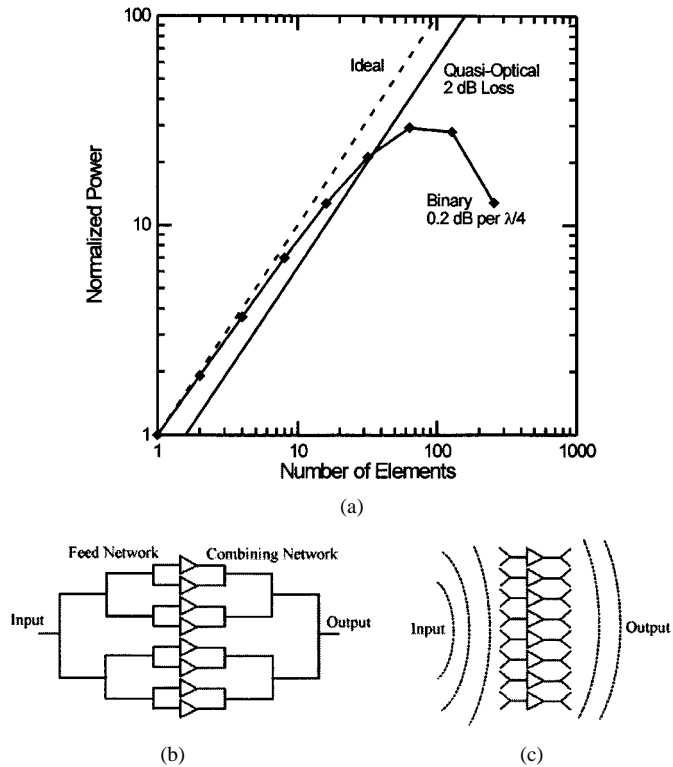

Fig. 1. (a) Output power available from (b) corporate and (c) quasi-optical power combiners as a function of the number of elements [13]. The binary power-combining curve was generated assuming eight elements can be arranged in a one-wavelength distance and each quarter-wave section of transmission line has 0.2-dB loss; the quasi-optical curve was generated assuming a 2-dB total loss. These numbers are typical for on-chip microstrip combiners and quasi-optical combiners at Ka -band.

The advantages of spatial combining are manifest for large numbers of devices. For example, to combine the outputs of 512 devices would normally require nine stages of binary circuit combining, but can be (and has been) implemented using a single quasi-optical surface. Fig. 1 illustrates this point. Note that the physical layout of the corporate combiners with many elements causes the transmission lines in the last stages of combining to become very long. As the number of devices increases, the losses in these lines become insurmountable. The output power of a quasi-optical combiner, on the other hand, will continue to grow in direct proportion to the number of devices combined. In this example, the quasi-optical combiner is superior when there are more than 32 elements. The quasi-optical advantage becomes more apparent at higher frequencies, where the shorter wavelengths allow denser device integration. For example, quasi-optical multipliers at 1 THz have generated output powers 200 times greater than any competing technology, a clear testament to this high-frequency advantage [14]. Furthermore, millimeter-wave quasi-optical transmitters could be inexpensively mass produced by taking advantage of monolithic integration.

Several other advantages of quasi-optical amplifiers have been noted. Since noise from the individual devices is largely uncorrelated, the broad-band noise figure of quasi-optical circuits tends to be similar to that of a single device [15]–[17]; for similar reasons, the excess phase noise power in quasi-optical systems decreases in proportion to the number of elements

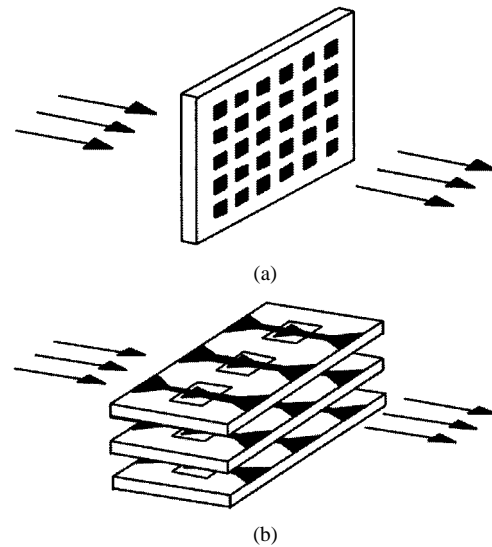

Fig. 2. (a) Tile and (b) tray amplifiers.

[12]. These properties allow an increased dynamic range in quasi-optical receivers [18]. Finally, quasi-optical devices tend to degrade gracefully as devices fail [19], and are insensitive to the single-point failures that could be catastrophic in other systems.

The traditional drawbacks to quasi-optics have been insufficient modeling, difficult packaging issues, the excitation of substrate modes, and thermal management. Recent advances have addressed many of these drawbacks, enabling quasi-optical power combining as a viable technology.

II. RETROSPECTIVE

An early demonstration of the strong potential for antenna-based power combiners was by Staiman *et al.* [20], who constructed a 100-W 100-element amplifier array at 410 MHz. Each amplifier fed a dipole antenna above a ground plane, with the dipoles interconnected and closely spaced. This approach has also been employed at millimeter-wave frequencies with some success. Durkin [21] describes a 35-GHz “active aperture” using IMPATT amplifiers driving a printed slot array. Chang *et al.* [22] also reported a Ka -band array using GaAs MMIC amplifiers and tapered-slot antennas in a tray approach. Mink [23] proposed a quasi-optical combining technique using an array of negative resistance devices in a semiconfocal resonant cavity. A more complete summary of historical work in this area is given in [24]–[26].

III. ARCHITECTURES, PACKAGING, AND MODELING

A. Grids, Tiles, and Arrays

The various quasi-optical architectures that have been reported can be classified as either a “tray” or a “tile” approach, as in Fig. 2. In the tile approach, the array couples to a wave propagating normal to the surface, whereas the beam propagation is tangential to the planar surface in a tray system. The tile approach lends itself to single-chip monolithic integration, but requires small-area unit cells that typically incorporate resonant antennas with limited bandwidth. The tray geometry

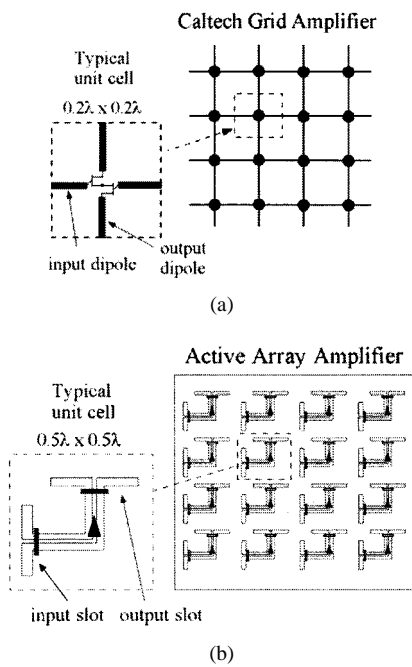

Fig. 3. Two tile architectures. (a) Grid amplifiers. (b) Active array amplifiers.

lends itself to broad-band traveling-wave antennas and simpler heat-removal, but at the expense of extra integration complexity.

Of the tile approaches, two distinct architectures have emerged: the so-called “grid” amplifier, and the active array amplifier. These approaches, illustrated in Fig. 3, are quite different, and each has its merits. The grid amplifier is an array of closely spaced differential transistor pairs. The input and outputs are cross polarized, and off-chip polarizers are used for tuning. The drawback of grids is that the small cell sizes limit the gain and power per cell to that available from a single differential pair. Since the active devices are very dense, however, the grid amplifier can be monolithically fabricated; this makes grids a very attractive technology for moderate gain and power applications that demand a single-chip mass-producible solution. Active arrays, on the other hand, use larger unit cells with more conventional antennas like patches or slots. This larger unit cell allows integration of multistage MMICs with higher gain and output power. By integrating the amplifiers in the longitudinal direction, tray amplifiers share this advantage. The passive radiating and tuning elements do tend to occupy a significant fraction of the active array and tray amplifier’s area; the most economical solution is to attach active MMICs to passive antennas. Active arrays and trays may find use in very-high power or gain applications.

B. Packaging

Efficient feeding of the input of a quasi-optical amplifier is another important issue. An ideal feed would transition from a standard guided wave to a plane wave with uniform amplitude and phase, efficiently illuminating the aperture of the quasi-optical array. Uniform illumination is important for two reasons: it gives a well-formed radiated output beam, and it insures that all the array elements saturate together. To preserve gain and noise figure, this transition must be made with as little loss as possible. For some applications, the radiated output beam may

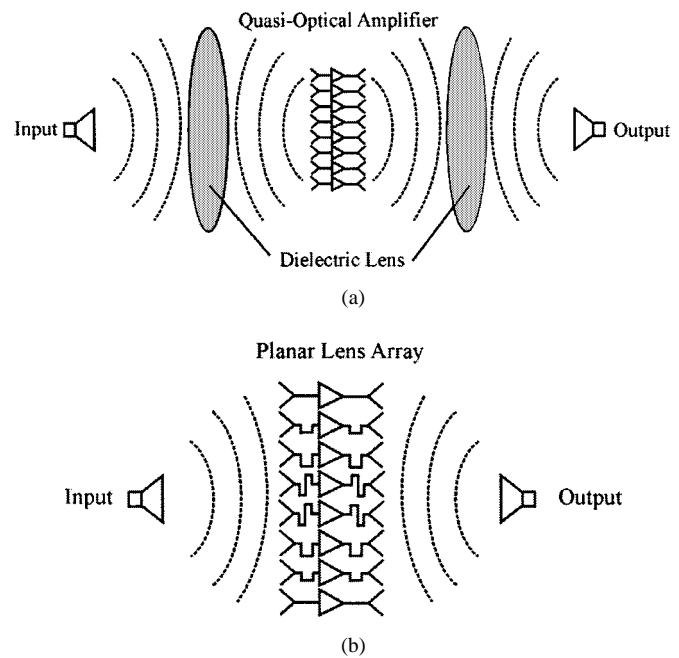

Fig. 4. (a) Lens-focused quasi-optical system. The focusing will cause a nonuniform power distribution at the plane of the amplifier. (b) Planar lens amplifier [28], [29]. The amplifier works as a planar Rotman lens, with transmission-line delays providing the proper phase shift.

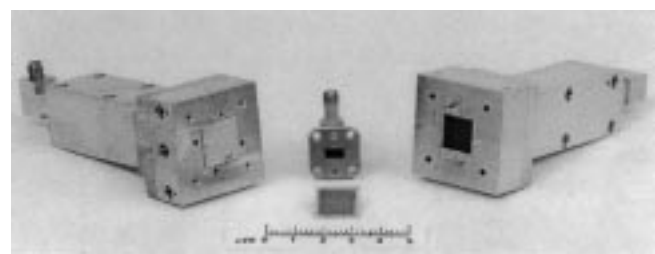
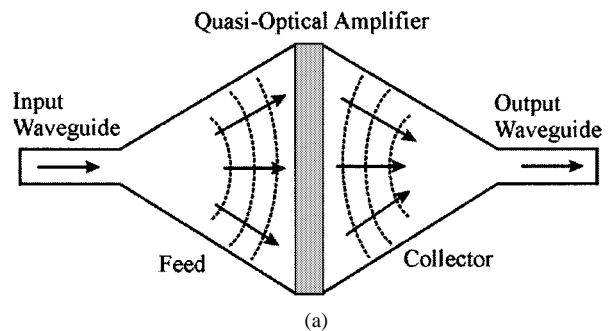

Fig. 5. (a) Quasi-optical amplifier in a waveguide fixture. Smaller arrays could be put into a single-mode waveguide; larger arrays must be put into an oversized structure, possibly with sidewall loading to insure a flat field. (b) Rockwell array amplifier in a tapered waveguide fixture [35].

be ideal. For other applications, such as a drop-in replacement for a traditional power amplifier (PA), the radiated quasi-optical output must be efficiently collected and transitioned back to a guided wave. Quasi-optical packaging fixtures have evolved steadily. The first quasi-optical amplifiers were measured in the far field of two horn antennas. Although this approach is useful for characterizing amplifiers in the laboratory, the very high path losses between the array and horns render this approach unusable for any practical application. Quasi-optical amplifiers

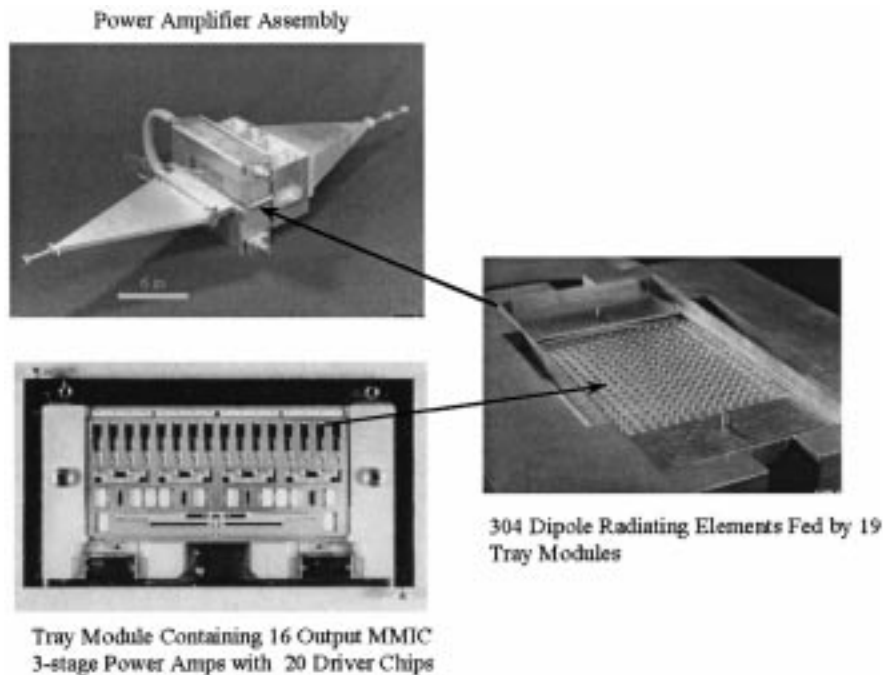

Fig. 6. Spatial combiner developed by Sanders [44].

have also been tested using dielectric lenses to capture more of the power radiated from the input and output horns [15], [27], as shown in Fig. 4(a), but this configuration is very bulky. Popović and others at the University of Colorado at Boulder have developed a planar lens amplifier that focuses the power by incorporating appropriate phase delays across a planar active array [28], [29]; this approach is illustrated in Fig. 4(b). Perhaps the most attractive solution is to include the amplifier in a guided-wave system, as shown in Fig. 5(a). York and others have demonstrated good results by incorporating tray amplifiers into a single-mode X -band waveguide [30], [31] and a broad-band coaxial waveguide [32]. Larger grids and arrays must be put into an overmoded guide, and care must be taken to insure that the arrays are illuminated uniformly without sacrificing too much power to higher order modes. Mortazawi and others have had considerable success using dielectric-loaded “hard horns” to excite array amplifiers with a near-uniform field [33], [34]. Researchers at Rockwell International have reported up to 9-dB small-signal gain and 1 W of saturated power from the flanges of a Ka -band monolithic array amplifier in a flared-waveguide fixture [35]; this fixture is shown in Fig. 5(b). Researchers at the California Institute of Technology, Pasadena, have also shown promising results in developing a waveguide-based mode converter for feeding grid amplifiers [36].

C. Modeling

The inputs and outputs of a quasi-optical component are radiated waves. The designer of a quasi-optical array must model how the electric and magnetic fields in the radiated waves will couple to the voltages and currents on the terminals of the active device. Although accurate modeling is still a challenge today, researchers have made significant progress in modeling the behavior of quasi-optical arrays.

Modeling of grid structures is most challenging since the elements are very strongly coupled and generally placed quite close together ($0.1\text{--}0.3\lambda$). Due to the strong interactions, modeling every element in large arrays can be a computationally daunting task. Steer and co-workers at North Carolina State University, Raleigh, have achieved some success at analyzing the entire grid [37], [38]. Instead of modeling the entire grid, it is often more convenient to picture an infinite two-dimensional lattice, and then take advantage of symmetry planes where the tangential fields vanish to define a single unit cell. This approach neglects edge effects and will be most valid for large arrays. The complexity of the modeling is reduced substantially: from analyzing the entire array to analyzing a single cell in an equivalent waveguide. The unit cell approach was originally developed to model grid oscillators [39] and was later extended to grid amplifiers [16]. Recent advances in commercially available computer-aided design (CAD) packages have enabled designers to model grids with remarkable success [40]. Similar unit-cell-based methods can be used to model the stability of grid amplifiers [41]. Furthermore, a careful choice of the cell size can minimize the deleterious effects of substrate modes [42].

Modeling of active array amplifiers is more akin to classical antenna array design. Although still challenging, there is a much larger knowledge base for this type of structure and, hence, numerous existing modeling codes can be used. These arrays use common planar antenna structures (slots, patches) that can be analyzed in a unit-cell configuration with appropriate boundary conditions (simulating the response in large arrays) to account for mutual coupling effects. Some successful efforts in global modeling of the entire array, including edge effects, has been reported in [43] for a combiner based on folded-slot antennas. Since mutual coupling is a smaller effect in these arrays in comparison to grids, often a design can be carried out using isolated

antenna impedances. However, most existing antenna models assume that the radiation takes place in an unbounded medium. This condition is violated for arrays operated in metallic enclosures, and this can have a strong influence on the driving-point impedances.

IV. CURRENT STATE-OF-THE-ART

Significant progress has been made in the laboratory development of solid-state spatial power combining. The results are too numerous to discuss exhaustively here. The following four demonstrations have been chosen to highlight some of the many promising results in each of the key design architectures.

A. Sanders 35-W 60-GHz Tray Amplifier

Arguably the most stunning accomplishment in spatial combiners was recently reported by researchers at Sanders [44], who described a combiner with 272 MMICs in operation simultaneously. This system is depicted in Fig. 6. This system uses a sectoral horn feed to a 17-element linear dipole array. Each dipole then couples energy to a tray containing 16 three-stage MMIC output amplifiers with 20 driver MMICs (one for each PA plus four additional pre-amps in the distribution network). The output signal from the 17×16 output dipole array network is collected using a pyramidal horn. This array reportedly generates 35-W continuous wave (CW) output power at 61 GHz, with 60 dB of small-signal gain and a 4-GHz bandwidth. The AM-PM distortion is 1°/dB. This combiner achieves an estimated 45%–50% collection efficiency. The extremely high gain of this system compares favorably with tube sources. We believe that this is the highest power solid-state V-band source reported to date.

B. UCSB 120-W X-Band Tray Amplifier

Researchers at the University of California at Santa Barbara (UCSB) have successfully implemented a spatial power combiner in a “tray” architecture [30], [31], as shown in Fig. 7. The tray approach permits the use of broad-band traveling-wave antennas [45] and improved functionality through circuit integration along the direction of propagation. Each tray consists of a number of tapered-slotline or finline transitions that couple energy to and from a rectangular waveguide aperture to a set of MMIC amplifiers. The finline transitions rest over a notched opening in the metal carrier to which the MMIC are attached. When the trays are stacked vertically, as shown in Fig. 7(b), the notched carriers form a rectangular waveguide aperture populated with the finline transitions. The use of the waveguide mode to distribute and collect energy to and from the set of amplifiers avoids loss mechanisms that would otherwise limit the efficiency in large corporate combiner structures.

An X-band module with 6–8 trays, each containing four 5-W GaAs MMIC amplifiers [see Fig. 7(c)], was assembled onto a 19-in rack-mounted assembly with a fan-cooled base plate for thermal management. A maximum power of 150-W CW was measured at 8 GHz, with an 8-V bias and total bias current of approximately 60 A. The measured graceful degradation characteristics for a similar 24-MMIC (six-tray) configuration show good qualitative agreement with the theory in [19]. The high

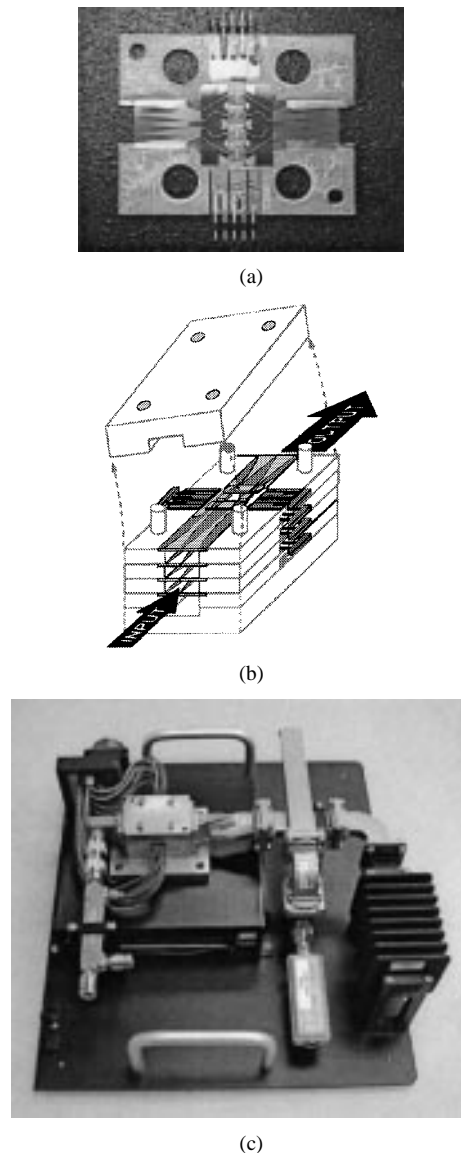

Fig. 7. UCSB X-band tray amplifier [30], [31]. (a) Individual tray showing finline or tapered-slot transitions and MMICs, along with microstrip interconnects. (b) Assembled system with end-caps, forming input and output waveguide apertures. (c) Photograph of the complete system using six trays four MMICs each.

power levels and broad-band performance, along with the superb graceful degradation characteristics, make this topology an attractive alternative to low-power vacuum-tube sources such as microwave power modules (MPMs).

C. Lockheed Martin/North Carolina State University 25-W 34-GHz Array Amplifier

Researchers at Lockheed Martin and North Carolina State University have recently demonstrated a planar “tiled” combiner system at Ka-band (34 GHz) [46], [47]. This system uses a 45-element double-sided active patch antenna array with a hard-horn feed. The array, unit cells, and assembled combiner system are shown in Fig. 8. In this case, the input is coupled to the array through a waveguide port on the hard-horn feed, and the output power is radiated directly into space. This arrangement would find use as a feed structure for a large reflector an-

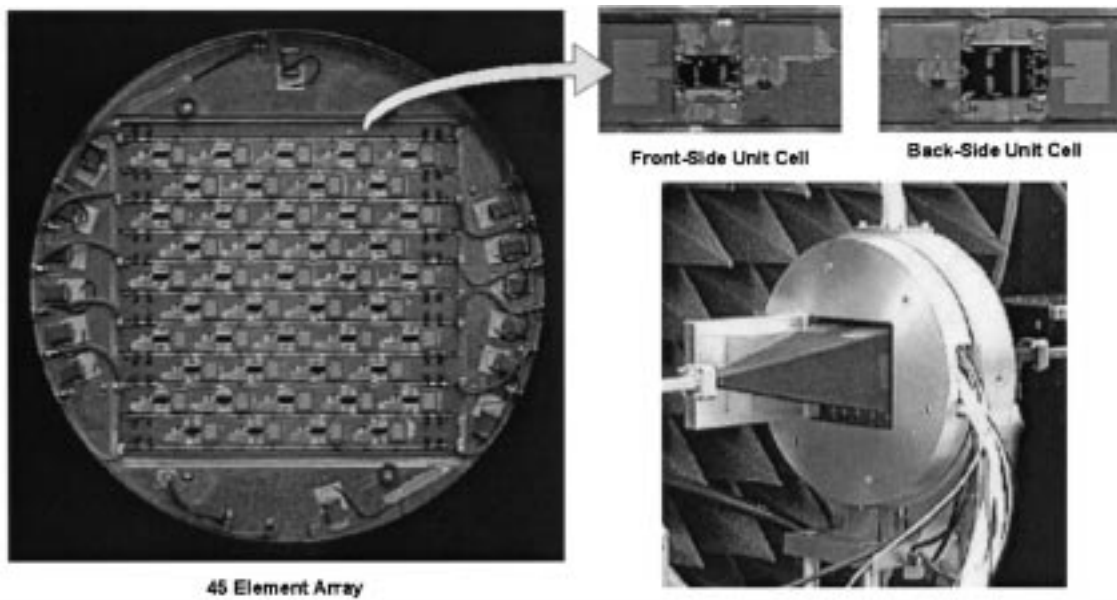

Fig. 8. Lockheed-Martin/North Carolina State University 45-element array producing 25 W at Ka -band [46], [47].

tenna or lens-focused system. The hard-horn feed utilizes dielectric sidewall loading to create a uniform field profile [33], [34], thus insuring equal drive power to the array elements. The MMIC amplifiers rest directly on a thick central ground plane through which the signal is coupled via integrated coaxial vias. This thick ground provides good input/output isolation, and allows for excellent thermal management. This particular system included a liquid-cooled baseplate.

Based on measurements of the radiation pattern and effective isotropic radiated power (EIRP) of the array, a radiated power of 44 dBm (25 W) was recorded at 34 GHz, with a 3-dB bandwidth of 800 MHz. The array has a small-signal gain of 10 dB at this frequency, and the power measurements were made at 3-dB gain compression

D. California Institute of Technology 5-W 37-GHz Grid Amplifier

Researchers at the California Institute of Technology have developed a single-chip monolithic grid amplifier using Rockwell pseudomorphic high electron-mobility transistor (pHEMT) technology [27]. Fig. 9(a) shows a section of the grid; the entire array incorporates 512 transistors in an area 1 cm on a side. The grid was characterized in a lens-focused system. The maximum small-signal gain is 8 dB with a 1.3 GHz (3.5%) 3-dB bandwidth. The power and gain saturation curves are shown in Fig. 9(b). Under 3-dB gain compression, the CW output power is 5 W with a power-added efficiency of 17%. The measured output third-order intercept power is 31 W, and the AM-PM conversion is 2°/dB. An aluminum-nitride ceramic heat spreader was used for thermal management. Measurements with an infrared camera show that the temperature at the surface of the grid is only 55 °C, with 60 °C hot spots, proving that earlier fears of destructive temperature rises were unfounded. These results are competitive with any single-chip MMIC amplifier.

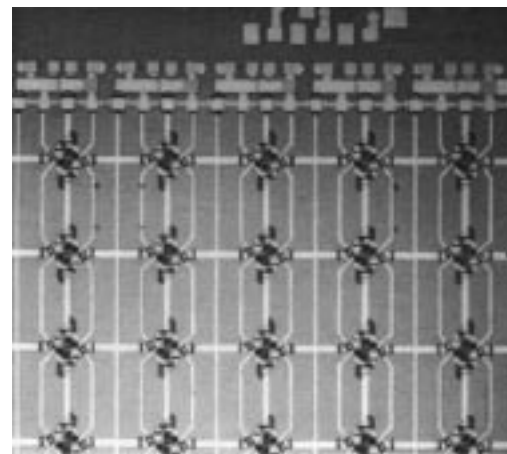

(a)

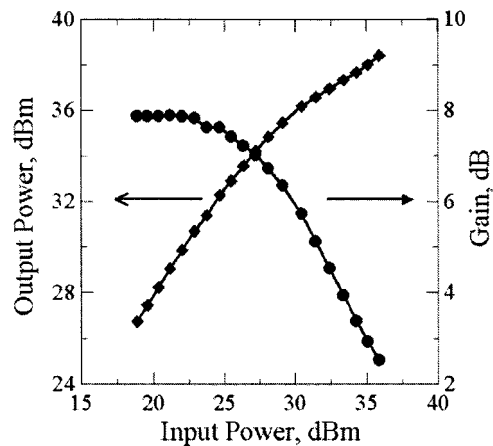

(b)

Fig. 9. (a) Section of a 512-transistor monolithic quasi-optical grid amplifier [27]. The grid unit cell period is 625 μm . (b) Large-signal gain and power saturation. At 5-W output, the estimated system loss is 2 dB.

V. CONCLUSIONS

Quasi-optical or spatial-combining techniques have been successfully developed and refined during the past several years, culminating in several promising demonstrations at microwave and millimeter-wave frequencies. As demand for bandwidth increases and communications systems continue to exploit higher frequencies, these techniques are likely to play a key role in future communications electronics.

REFERENCES

- [1] K. Chang and C. Sun, "Millimeter-wave power-combining techniques," *IEEE Trans. Microwave Theory Tech.*, vol. MTT-31, pp. 91–107, Feb. 1983.
- [2] K. J. Russell, "Microwave power combining techniques," *IEEE Trans. Microwave Theory Tech.*, vol. MTT-27, pp. 472–478, May 1979.
- [3] M. Dydyk, "Efficient power combining," *IEEE Trans. Microwave Theory Tech.*, vol. MTT-28, pp. 755–762, July 1980.
- [4] Y. C. Chen, D. L. Ingram, R. Lai, M. Barsky, R. Grunbacher, T. Block, H. C. Yen, and D. C. Streit, "A 95-GHz InP HEMT MMIC amplifier with 427-mW power output," *IEEE Microwave Guided Wave Lett.*, vol. 8, pp. 399–401, Nov. 1998.
- [5] Y. C. Chen, D. L. Ingram, D. Yamauchi, B. Brunner, J. Kraus, M. Barsky, R. Grunbacher, S. K. Cha, R. Lai, T. Block, M. Wojtowicz, T. P. Chin, B. Allen, H. C. Yen, and D. C. Streit, "A single chip 1-W HEMT V -band module," in *IEEE MTT-S Int. Microwave Symp. Dig.*, Anaheim, CA, 1999, pp. 149–152.
- [6] TriQuint. Product Data Sheet, TGA1141-EPU. [Online]. Available: www.triquint.com.
- [7] Raytheon. Product Data Sheet, RMPA39200. [Online]. Available: www.raytheon.com.
- [8] Sanders. Product Data Sheet, SGPA-07006-CC. [Online]. Available: www.sanders.com.
- [9] D. L. Ingram, Y. C. Chen, I. Stones, D. Yamauchi, B. Brunner, P. Huang, M. Biedenbender, J. Elliott, R. Lai, D. C. Streit, K. F. Lau, and H. C. Yen, "Compact W -band solid-state MMIC high power sources," in *IEEE MTT-S Int. Microwave Symp. Dig.*, Boston, MA, 2000, pp. 955–958.
- [10] E. Stenger, M. Sarantos, E. Niehenke, H. Fudem, C. Schwerdt, F. Kuss, D. Strack, G. Hall, and J. Matsi, "A miniature MMIC one-watt W -band solid-state transmitter," in *IEEE MTT-S Int. Microwave Symp. Dig.*, Denver, CO, 1997, pp. 431–434.
- [11] N. Escalera, W. Boger, P. Denisuk, and J. Dobosz, " K -band 30 watts solid state power amplifier," in *IEEE MTT-S Int. Microwave Symp. Dig.*, Boston, MA, 2000, pp. 561–563.
- [12] R. A. York, "Some considerations for optimal efficiency and low noise in large power combiners," *IEEE Trans. Microwave Theory Tech.*, vol. 49, pp. 1477–1482, Aug. 2001.
- [13] B. C. Deckman, "Active quasi-optics and measurements," Ph.D. dissertation, Dept. Elect. Eng., California Inst. Technol., Pasadena, CA, 2000.
- [14] A. Moussessian, M. C. Wanke, Y. Li, J.-C. Chiao, S. J. Allen, T. W. Crowe, and D. B. Rutledge, "A terahertz grid frequency doubler," *IEEE Trans. Microwave Theory Tech.*, vol. 46, pp. 1976–1981, Nov. 1998.
- [15] M. Kim, E. A. Sovero, J. B. Hacker, M. P. DeLisio, J.-C. Chiao, S.-J. Li, D. R. Gagnon, J. J. Rosenberg, and D. B. Rutledge, "A 100-element HBT grid amplifier," *IEEE Trans. Microwave Theory Tech.*, vol. 41, pp. 1762–1771, Oct. 1993.
- [16] M. P. DeLisio, S. W. Duncan, D.-W. Tu, C.-M. Liu, A. Moussessian, J. J. Rosenberg, and D. B. Rutledge, "Modeling and performance of a 100-element pHEMT grid amplifier," *IEEE Trans. Microwave Theory Tech.*, vol. 44, pp. 2136–2144, Dec. 1996.
- [17] M. P. DeLisio, R. M. Weikle, II, and D. B. Rutledge, "Element efficiency and noise in grid arrays," *IEEE Trans. Microwave Theory Tech.*, vol. 46, pp. 1949–1955, Nov. 1998.
- [18] J. B. Hacker, R. M. Weikle, II, M. Kim, M. P. DeLisio, and D. B. Rutledge, "A 100-element planar Schottky diode grid mixer," *IEEE Trans. Microwave Theory Tech.*, vol. 40, pp. 557–562, Mar. 1992.
- [19] D. B. Rutledge, N.-S. Cheng, R. A. York, R. M. Weikle, II, and M. P. DeLisio, "Failures in power-combining arrays," *IEEE Trans. Microwave Theory Tech.*, vol. 47, pp. 1077–1082, July 1999.
- [20] D. Staiman, M. E. Breesee, and W. T. Patton, "New technique for combining solid-state sources," *IEEE J. Solid-State Circuits*, vol. SC-3, pp. 238–243, Sept. 1968.
- [21] M. F. Durkin, R. J. Eckstein, M. D. Mills, and M. S. Stringfellow, "35-GHz active aperture," in *IEEE MTT-S Int. Microwave Symp. Dig.*, Los Angeles, CA, 1981, pp. 425–427.
- [22] J. Chang, D. H. Schaubert, K. S. Yngvesson, J. Huang, V. Jamnejad, D. Rascoe, and A. L. Riley, " K -band power-combining MMIC array," in *15th Int. Infrared Millimeter-Waves Conf. Dig.*, Orlando, FL, Dec. 1990, pp. 532–534.
- [23] J. W. Mink, "Quasioptical power combining of solid-state millimeter-wave sources," *IEEE Trans. Microwave Theory Tech.*, vol. MTT-34, pp. 273–279, Feb. 1986.
- [24] R. A. York and Z. B. Popović, Eds., *Active and Quasi-Optical Arrays for Solid-State Power Combining*. New York: Wiley, 1997.
- [25] J. A. Navarro and K. Chang, *Integrated Active Antennas and Spatial Power Combining*. New York: Wiley, 1996.
- [26] A. Mortazawi, T. Itoh, and J. Harvey, Eds., *Active Antennas and Quasi-Optical Arrays*. Piscataway, NJ: IEEE Press, 1999.
- [27] B. Deckman, D. S. Deakin, Jr., E. Sovero, and D. Rutledge, "A 5-watt, 37-GHz monolithic grid amplifier," in *IEEE MTT-S Int. Microwave Symp. Dig.*, Boston, MA, 2000, pp. 805–808.
- [28] J. S. H. Schoenberg and Z. B. Popović, "Planar lens amplifier," in *IEEE MTT-S Int. Microwave Symp. Dig.*, San Diego, CA, 1994, pp. 429–432.
- [29] S. Hollung, A. E. Cox, and Z. B. Popović, "A bi-directional quasi-optical lens amplifier," *IEEE Trans. Microwave Theory Tech.*, vol. 45, pp. 2352–2357, Dec. 1997.
- [30] N.-S. Cheng, P. Jia, D. B. Rensch, and R. A. York, "A 120-W X -band spatially combined solid-state amplifier," *IEEE Trans. Microwave Theory Tech.*, vol. 47, pp. 2557–2561, Dec. 1999.
- [31] N.-S. Cheng, A. Alexanian, M. G. Case, D. Rensch, and R. A. York, "40 watt CW broad-band spatial power combiner using dense finline arrays," *IEEE Trans. Microwave Theory Tech.*, vol. 47, pp. 1070–1076, July 1999.
- [32] P. Jia, L.-Y. Chen, and R. A. York, "Ultra-broadband coaxial waveguide power combiner," *IEEE Trans. Microwave Theory Tech.*, to be published.
- [33] T. Ivanov and A. Mortazawi, "A two-stage spatial amplifier with hard horn feeds," *IEEE Microwave Guided Wave Lett.*, vol. 6, pp. 88–90, Feb. 1996.
- [34] M. A. Ali, S. C. Ortiz, T. Ivanov, and A. Mortazawi, "Analysis and measurement of hard-horn feeds for the excitation of quasi-optical amplifiers," *IEEE Trans. Microwave Theory Tech.*, vol. 47, pp. 479–487, Apr. 1999.
- [35] E. A. Sovero, J. B. Hacker, J. A. Higgins, D. S. Deakin, and A. L. Sailer, "A K -band monolithic quasi-optic amplifier," in *IEEE MTT-S Int. Microwave Symp. Dig.*, Baltimore, MD, 1998, pp. 1453–1456.
- [36] T. Kamei, C.-T. Cheung, J. J. Rosenberg, and D. B. Rutledge, "Design and simulation of a mode converter for the excitation of quasioptical amplifiers," presented at the 26th Gen. Assembly Int. URSI Dig., Toronto, ON, Canada, 1999, p. 688.
- [37] T. W. Nuteson, M. B. Steer, K. Naishadham, J. W. Mink, and J. Harvey, "Electromagnetic modeling of finite grid structures in quasi-optical systems," in *IEEE MTT-S Int. Microwave Symp. Dig.*, San Francisco, CA, June 1996, pp. 1251–1254.
- [38] T. W. Nuteson, H.-S. Hwang, M. B. Steer, K. Naishadham, J. Harvey, and J. W. Mink, "Analysis of finite grid structures with lenses in quasi-optical systems," *IEEE Trans. Microwave Theory Tech.*, vol. 45, pp. 666–672, May 1997.
- [39] Z. B. Popović, R. M. Weikle, M. Kim, and D. B. Rutledge, "A 100-MESFET planar grid oscillator," *IEEE Trans. Microwave Theory Tech.*, vol. 39, pp. 193–200, Mar. 1990.
- [40] P. Preventza, B. Dickman, E. Sovero, M. P. DeLisio, J. J. Rosenberg, and D. B. Rutledge, "Modeling of quasi-optical arrays," in *IEEE MTT-S Int. Microwave Symp. Dig.*, Anaheim, CA, 1999, pp. 563–566.
- [41] C.-M. Liu, M. P. DeLisio, A. Moussessian, and D. B. Rutledge, "Stability of grid amplifiers," *IEEE Trans. Microwave Theory Tech.*, vol. 46, pp. 769–774, June 1998.
- [42] A. Al-Zayed, R. R. Swisher, F. Lecuyer, A. C. Guyette, Q. Sun, and M. P. DeLisio, "Reduction of substrate mode effects in power-combining arrays," *IEEE Trans. Microwave Theory Tech.*, vol. 6, pp. 1067–1072, June 2001.
- [43] M. N. Abdulla, U. A. Mughal, H.-S. Tsai, M. B. Steer, and R. A. York, "A full-wave system simulation of a folded-slot spatial power combining amplifier array," in *IEEE MTT-S Int. Microwave Symp. Dig.*, Anaheim, CA, 1999, pp. 559–562.
- [44] J. J. Sowers, D. J. Pritchard, A. E. White, W. Kong, O. S. A. Tang, D. R. Tanner, and K. Jablinsky, "A 36 W, V -band, solid-state source," in *IEEE MTT-S Int. Microwave Symp. Dig.*, Anaheim, CA, 1999, pp. 235–238.

- [45] P. Jia, L.-Y. Chen, N.-S. Cheng, and R. A. York, "Design of waveguide finline arrays for spatial power combining," *IEEE Trans. Microwave Theory Tech.*, vol. 49, pp. 609–614, Apr. 2001.
- [46] S. Ortiz, J. Hubert, E. Schlecht, L. Mirth, and A. Mortazawi, "A 25 watt and a 50 watt Ka -band quasi-optical amplifier," in *IEEE MTT-S Int. Microwave Symp. Dig.*, Boston, MA, 2000, pp. 797–800.
- [47] S. Ortiz, J. Hubert, L. Mirth, and A. Mortazawi, "A 25 W Ka -band quasi-optical amplifier array," *IEEE Trans. Microwave Theory Tech.*, submitted for publication.



Michael P. DeLisio (S'90–A'95–M'96–SM'01) was born in Southfield, MI, on July 29, 1968. He received the B.S.E. degree in electrical engineering from The University of Michigan at Ann Arbor, in 1990, and the M.S. and Ph.D. degrees in electrical engineering from the California Institute of Technology in Pasadena, in 1991 and 1996, respectively.

In January 1996, he joined the Department of Electrical Engineering, University of Hawaii at Manoa, where he is an Associate Professor, currently on leave. He also holds a Visiting Associate position

at the California Institute of Technology. In 2001, he joined Wavestream Wireless Technologies, West Covina, CA, as a Chief Technical Officer. His technical interests include microwave and millimeter-wave quasi-optical power-combining and high-frequency devices, circuits, and antennas.

Prof. DeLisio is a member of Tau Beta Pi, Eta Kappa Nu, and the American Society for Engineering Education. He was the secretary of the 1999 IEEE Microwave Theory and Techniques Society (IEEE MTT-S) Administrative Committee (AdCom), and is currently an IEEE MTT-S AdCom member.



Robert A. York (S'85–M'89–SM'99) received the B.S. degree in electrical engineering from the University of New Hampshire, Durham, in 1987, and the M.S. and Ph.D. degrees in electrical engineering from Cornell University, Ithaca, NY, in 1989 and 1991, respectively.

He is currently a Professor of electrical and computer engineering at the University of California at Santa Barbara (UCSB), where his group is currently involved with the design and fabrication of novel microwave and millimeter-wave circuits,

high-power microwave and millimeter-wave amplifiers using spatial combining and wide-bandgap semiconductor devices, and application of ferroelectric materials to microwave and millimeter-wave circuits and systems.

Dr. York was the recipient of the 1993 Army Research Office Young Investigator Award and the 1996 Office of Naval Research Young Investigator Award.