

Multioctave Spatial Power Combining in Oversized Coaxial Waveguide

Pengcheng Jia, *Student Member, IEEE*, Lee-Yin Chen, *Student Member, IEEE*, Angelos Alexanian, *Member, IEEE*, and Robert A. York, *Senior Member, IEEE*

Abstract—We describe a multioctave power-combiner structure using finline arrays in an oversized coaxial waveguide. The spectral-domain method (SDM) is used to compute the propagation constant in this structure, and is verified with HFSS simulations. The SDM method is then employed to synthesize broad-band tapered impedance transformers in finline for coupling energy to and from a set of monolithic microwave integrated circuit (MMIC) amplifiers. A modular assembly is described using a sectoral tray architecture. The concept is demonstrated for a 32-MMIC system using low-power traveling-wave amplifier MMICs, providing a 3-dB bandwidth of 13 GHz (3–16 GHz). An output combining loss of 1 dB is estimated from the small-signal measurements, suggesting a combining efficiency of $\sim 75\%$ for 32 MMICs.

Index Terms—Coaxial waveguide, slotline array, spatial power combining, ultra-broad-band.

I. INTRODUCTION

HIGH-POWER amplifiers with multioctave bandwidths are difficult to realize in monolithic microwave integrated circuit (MMIC) technology, particularly when the power requirements call for combining the outputs of multiple MMICs simultaneously. Recently, we have described an efficient combining technique using finline arrays in a rectangular waveguide, capable of operation over the full waveguide band [1]. In this approach, finline transitions couple energy to and from the waveguide field to a set of MMIC amplifiers. A 24-MMIC system produced over 120-W continuous wave (CW) in an X-band waveguide environment [1].

In principle it is possible to extend the operating frequency and amplifier capacity of such combiners by operating in a multimode environment; in fact, we have found that the use of very dense finline arrays can act to suppress high-order modes in such structures. However, there are other difficulties. First, since the array is excited by a TE_{10} mode, the amplifier elements are driven nonuniformly, which can reduce the efficiency and distort the saturation characteristics of the system. Secondly, the rectangular waveguide environment is dispersive, which complicates broad-band impedance matching over an extended frequency range.

Manuscript received November 13, 2000. This work was supported in part by the Office of Naval Research Multidisciplinary University Research Initiative IMPACT Program under Grant N00014-96-1-1215, and in part by the Army Research Office Multidisciplinary University Research Initiative Program under Grant DAAG55-98-1-0001.

P. Jia, L.-Y. Chen, and R. A. York are with the Electrical and Computer Engineering Department, University of California at Santa Barbara, Santa Barbara, CA 93106 USA.

A. Alexanian is with RF Micro Devices Inc., Billerica, MA 01821 USA.
 Publisher Item Identifier S 0018-9480(02)04057-7.

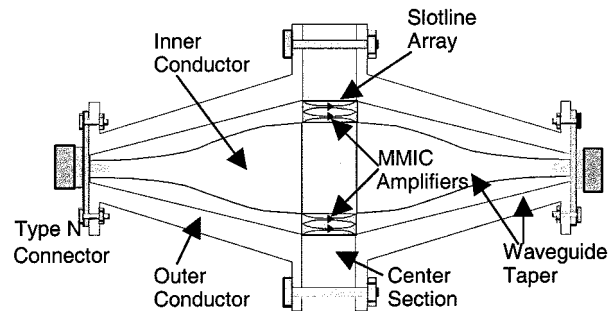

Fig. 1. Schematic of an oversized coaxial waveguide combiner housing a dense finline array, with tapered transitions from a type-N connector.

These difficulties can be addressed by adapting the approach to a TEM waveguiding environment, such as a coaxial waveguide. Fig. 1 illustrates how this might be done by using radial tapered-slotline (finline) structures distributed uniformly in the annular aperture of an oversized coax. The combiner is fed by gradually flared coaxial lines, tapering to standard coaxial connectors at either end. This structure can accommodate a large number of amplifiers, provide uniform illumination of the array, and can be designed for ultra-wide-band operation.

The concept was first introduced by Alexanian and York in [2], with a preliminary demonstration of the idea using passive elements. In this paper, we describe the synthesis of optimum finline structures for realizing multioctave operation of such coaxial combiner structures, using an adaptation of procedures developed for the rectangular waveguide combiners [3]. These designs are verified by measurements on finline arrays with matched terminations. The design of a 32-MMIC combiner is then described and demonstrated using these optimized finline structures. Inexpensive low-power traveling-wave amplifier (TWA) MMICs were chosen as a demonstration vehicle. The combiner reproduced the individual MMIC frequency response from 2 to 16 GHz, with a 75% combining efficiency.

II. SPECTRAL-DOMAIN MODELING OF THE FINLINE ARRAY

The finline structure can be easily analyzed with a modern electromagnetic (EM) simulator code. However, the procedure for synthesizing a broad-band impedance-matching transformer (described in the following section) requires a more efficient code that can rapidly and iteratively evaluate the propagation constant of the structure over a range of frequencies and physical dimensions. The spectral-domain method (SDM) is well suited for this purpose [4].

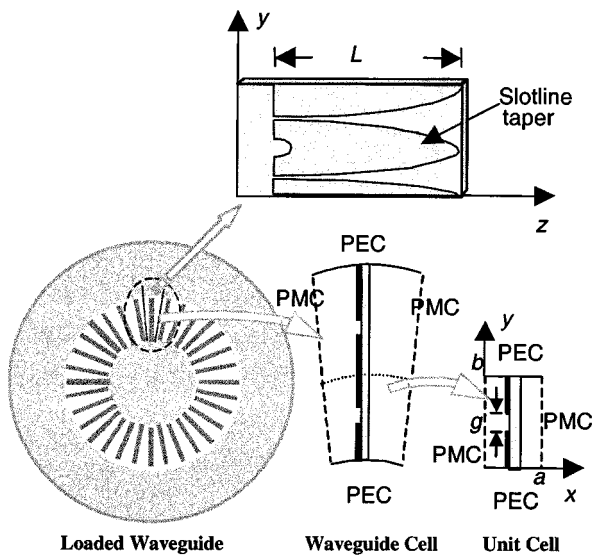

Fig. 2. Schematic cross section of a coaxial waveguide with a uniform loading of radial finline structures.

A cross section of the loaded coaxial line is shown in Fig. 2. Here, we assume that each substrate carries two separate slotline tapers, and that there is intimate electrical contact with the inner and outer coaxial conductors. Due to the symmetric loading and a dominant mode excitation, the computation domain can be reduced to a waveguide cell, with perfect electrical conductor (PEC) and perfect magnetic conductor (PMC) boundary conditions applied. The PEC boundary condition is applied again to divide the waveguide cell radially into two unit cells. Each unit cell is left with one tapered slotline and a constant ratio of outer radius to inner radius ratio, thereby maintaining identical characteristic impedances. This unit cell can be modeled in cylindrical coordinates. However, for the convenience of applying the method and codes previously developed for rectangular structures in [1], each unit cell is approximated by a parallel-plate waveguide cell.

At this point, the SDM approach is virtually identical with that reported for rectangular waveguide finline arrays, as elaborated in [3]. Only the sidewall boundary conditions are changed, which is a simple step in the SDM method. Hence, we refer the reader to [3]–[6] for details.

The effective permittivity versus normalized slot width for a range of frequencies from 4 to 18 GHz is shown in Fig. 3, assuming a 32-tray system with 10-mil aluminum–nitride substrates, as described in [2]. Clearly there is little variation of the propagation constant with frequency, indicating quasi-TEM behavior as desired.

As a numerical check on the SDM code, we analyzed the structure at one particular frequency using Agilent's High Frequency Structure Simulator (HFSS). This is shown in Fig. 3 for comparison, indicating good agreement with the SDM code. Furthermore, we observed from HFSS simulation that the next higher mode excited in the unit cell is over 10 dB lower in magnitude than the dominant mode, and the third higher mode is 30 dB lower.

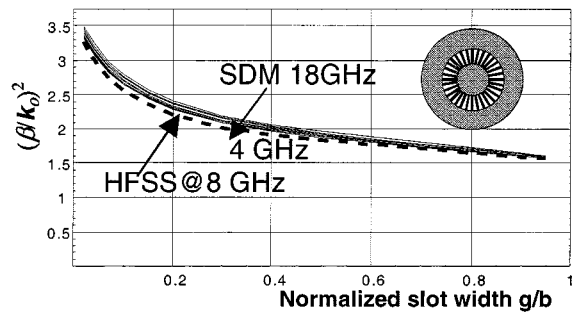

Fig. 3. Effective permittivity for a 32-tray system for varying slot width and frequency.

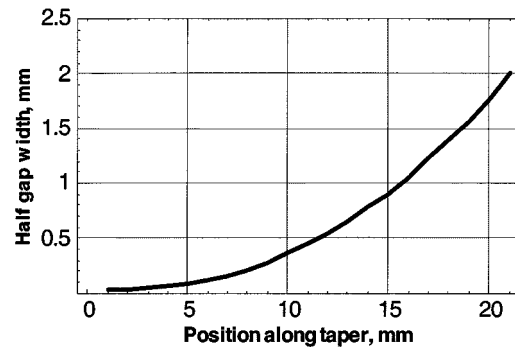

Fig. 4. Normalized gapwidth versus location along the optimal tapered slotline for a 4–18-GHz 32-tray system of finlines on 10-mil AlN.

III. SYNTHESIS OF OPTIMIZED TAPERS

In a 32-tray combiner, the input impedance of each circuit tray is 32 times the characteristic impedance of the flared coaxial waveguide, which was chosen to be $30\ \Omega$. Accordingly, at the largest slot width, the terminal impedance is $480\ \Omega$. At the other end of the taper, we must connect to a $50\text{-}\Omega$ MMIC amplifier, which sets the target gap size. The design challenge is, therefore, to realize a broad-band 9.6:1 impedance transformation to couple energy from the coax into a set of $50\text{-}\Omega$ MMIC amplifiers.

The design problem can be summarized as follows. Given the physical dimensions of the input and output gaps on the slotline, along with the waveguide and substrate parameters, optimize the shape of the taper to realize a specified bandwidth and return loss. The problem is directly analogous to the synthesis of tapered transmission-line impedance transformers. We have previously reported an iterative procedure in [3] for computing the taper shape. This method yields the shortest transformer for a specified cutoff frequency and return loss. Using this procedure and the SDM results of Fig. 3, an optimized taper for a 4–18-GHz 32-tray system is shown in Fig. 4 for a specified return loss of $-15\ \text{dB}$.

Once the taper shape is known, the frequency response can be computed using an EM simulator such as HFSS. This is shown in Fig. 5, confirming the design criteria. Also shown is the approximate analytic result using the theory of small reflections [7], [8]. It should be stressed that the sophisticated EM simulator provides an important check on the validity of the synthesis procedure, and can help fine tune the design once a near-optimal

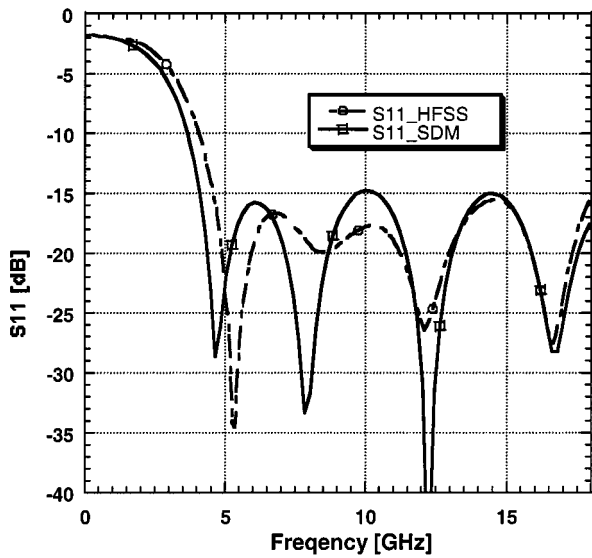

Fig. 5. Reflection coefficient comparison between SDM and Agilent HFSS for the optimal taper design of Fig. 4.

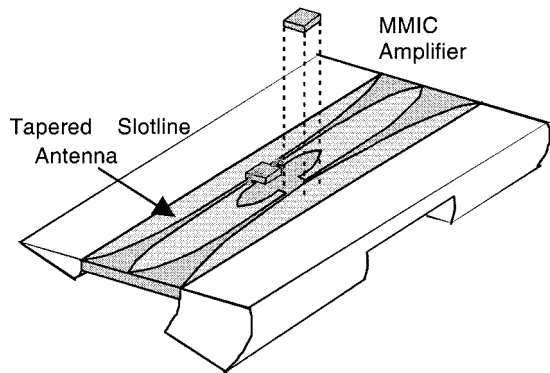

Fig. 6. Tray design for the modular coaxial combiner system.

solution has been obtained by more computationally efficient means, as described in [3].

IV. PASSIVE COMBINER MEASUREMENTS

The slotline transition is realized on a dielectric substrate, and rests over a notched opening in a wedge-shaped metal tray, providing broad-band impedance match from the coaxial waveguide to the MMIC amplifiers. A single tray is illustrated in Fig. 6. When the trays are stacked radially, the notched carriers form a coaxial waveguide aperture populated with the slotline transitions.

The optimized finline transition design was first tested using an array of transitions and terminating each in a 50-Ω resistor. These transitions were fabricated on 10-mil AlN substrates with 3-μm gold metallization. The card design is shown in the inset of Fig. 7. The resistors were single-wrap chip resistors and wire bonded to the finline. The reflection coefficient measurements for 32- and 16-tray systems are shown in Fig. 7. These show good qualitative agreement with the theoretical curves in Fig. 5, although the maximum reflection coefficient is somewhat higher in the passband (~ -10 dB), and there is evidence of some mismatch at the interface to the type-N connector, leading

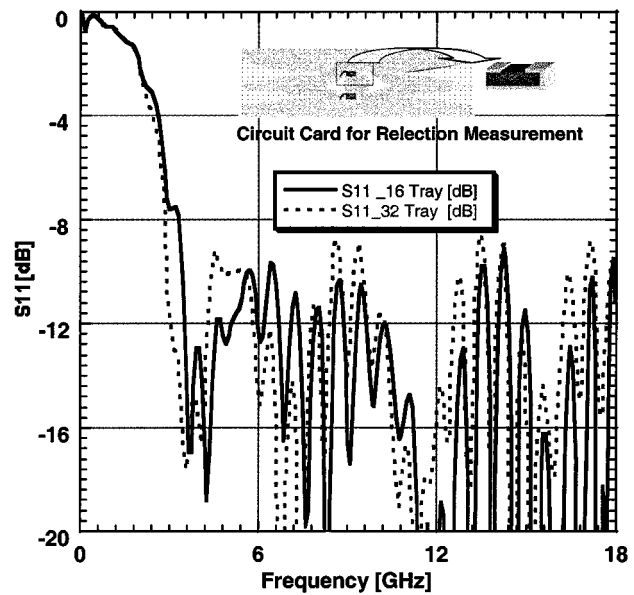

Fig. 7. Return loss measurement for 16- and 32-tray combiner with 50-Ω terminations on the finline structures. Inset shows circuit configuration.

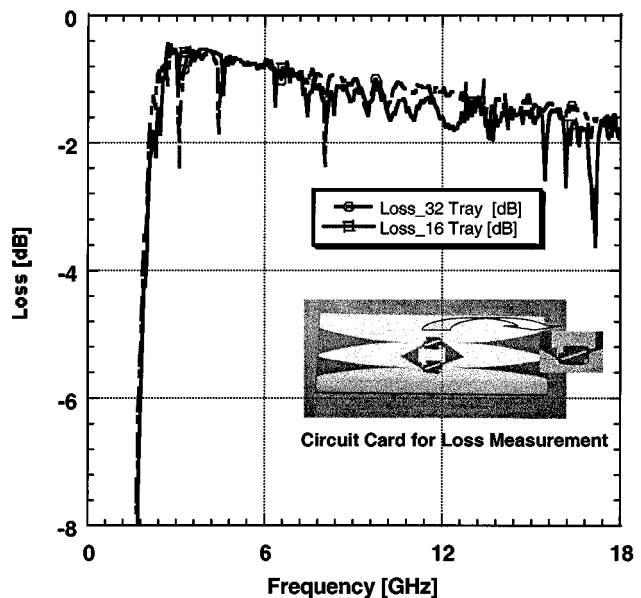

Fig. 8. Dissipative loss for 16- and 32-tray combiners with 50-Ω microstrip through line in place of the active device. Inset shows circuit configuration.

to the rapid undulations in the frequency response. We attribute the latter to a poor electrical connection between the type-N connector and center-conductor of the coaxial flare.

Low combining losses are required to maintain good combining efficiency. We estimate the combining losses as follows. A set of back-to-back finline cards is fabricated, with a 50-Ω microstrip through line bonded in place of the MMIC amplifier to connect the input and output antennas. This is indicated in the inset of Fig. 8. The microstrip lines are bonded to the surface of circuit card by eutectic solder and to the end of the slotline taper by 1-mil gold wires, which are approximately 300 μm in length.

Fig. 8 shows the measured dissipative loss for 16- and 32-tray combiners using the 50-Ω microstrip through line. The loss increases approximately as \sqrt{f} , as expected. Again, we see evi-

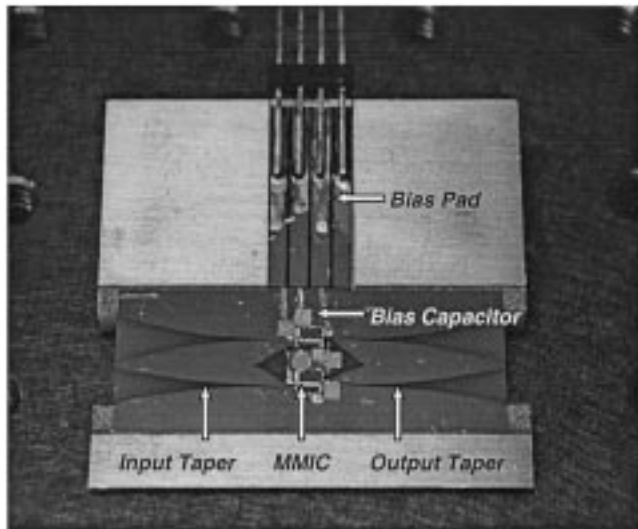

Fig. 9. Circuit tray with MMICs.

dence of mismatch at the type-N connector that leads to small periodic dips in the loss (these do not correlate with the excitation of higher order modes). Although this measurement does not exactly mimic the response with a nonreciprocal active amplifier, it allows us to roughly quantify the combining loss as one-half of the measured total loss. Thus, the combining loss varies from approximately 0.3 dB at 4 GHz to 1 dB at 18 GHz. This translates to a potential combining efficiency in excess of 75% over the entire band.

It is important to note that the dissipative loss stays constant when we double the number of elements in the waveguide slot-line array, consistent with the observation in [3] that dissipative loss is approximately independent of the number of transitions used. This characteristic makes the coaxial combiner promising for combing the power from a large number of active devices.

V. ACTIVE COAXIAL WAVEGUIDE POWER COMBINER

A final test of the combiner system used an array of 16 broad-band MMIC amplifiers. A Triquint TGA8349 TWA circuit was selected for the active amplifiers. Typical input voltage standing-wave ratio (VSWR) of TGA8349 is 1.2:1, and output SWR is 1.3:1. This MMIC can generate 16-dBm output power at 1-dB compression point. The small-signal bandwidth of this MMIC is from dc to 14 GHz.

The circuit tray is shown in Fig. 9. Each tray carries a circuit card with two MMICs on it. A total of 32 MMICs were integrated into a 16-tray system. The biasing pads are bonded at the side of the circuit tray as shown. The dual-gate FET MMIC needs four voltages for gate, drain, control, and ground bias. Single-layer capacitors are placed for biasing, and bonding wire is used for the dc and RF connection. The 10-mil-thick AlN substrate sits on the grooves of the aluminum circuit holder, carrying all of the taper slotlines, MMICs, and bias capacitors.

A perspective view of the loaded center section is shown in Fig. 10. The coaxial waveguide opening is formed when we stack all the circuit trays together. Fig. 11 shows the completely assembled system including broad-band coaxial tapers for feeding the loaded section.

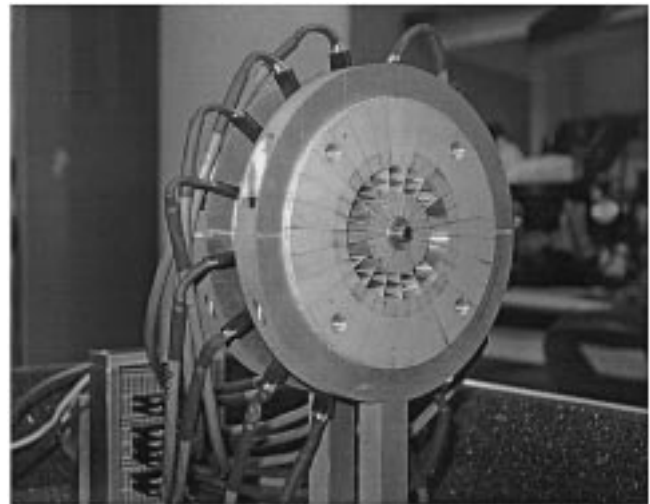

Fig. 10. Side view of the loaded section.

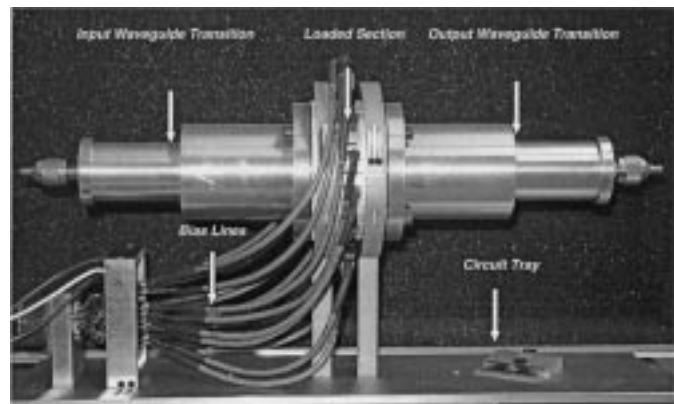

Fig. 11. Overview of the coaxial waveguide power combiner.

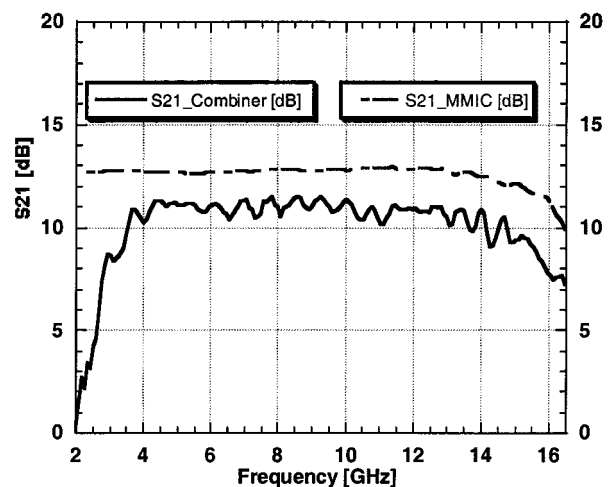

Fig. 12. Measured small-signal gain of the active combiner and individual MMIC amplifier.

Figs. 12 and 13 show the small-signal gain and reflection coefficient of the completed active combiner system. The broad-band property is verified by both of the figures. The coaxial waveguide power combiner has 10–11.5-dB gain over a broad-band from 3.5 to 14 GHz. The upper end bandwidth of the combiner is limited by the MMIC. The combiner itself

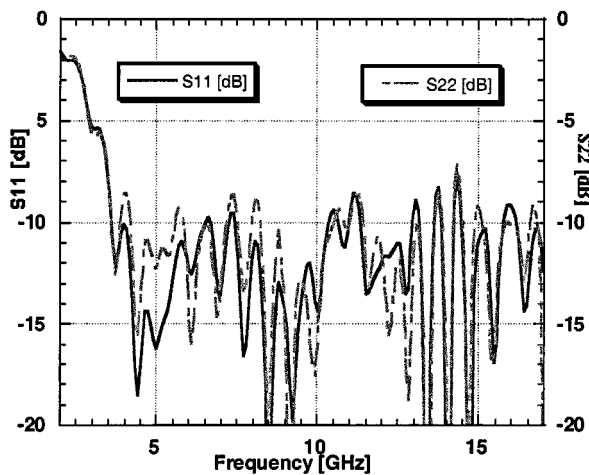

Fig. 13. Reflection coefficient of both input and output ports for the active system.

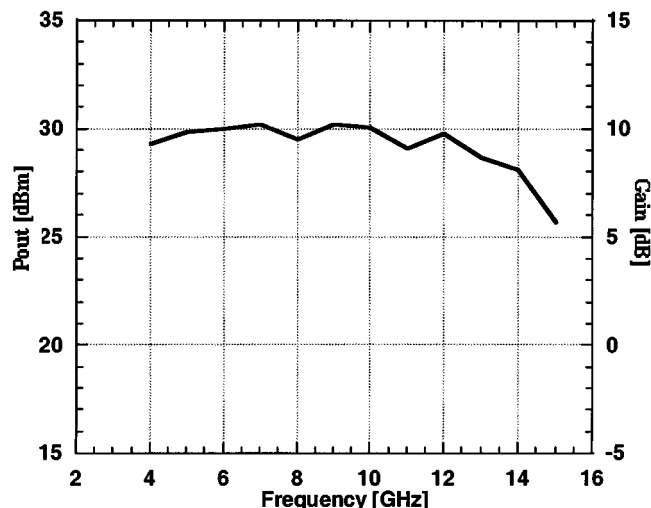

Fig. 15. Output power and gain versus frequency.

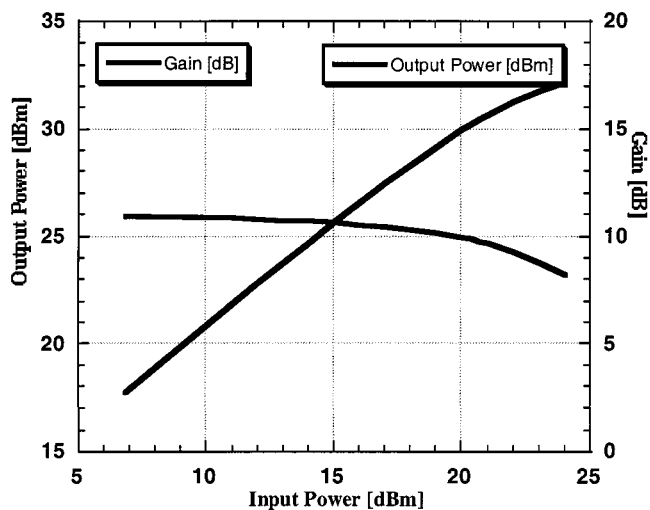

Fig. 14. Output power and gain versus input power.

has a potential to work up to 18 GHz. The loss of the system is consistent with the loss of the passive combiner. The total loss of the combiner including ohmic and mismatch losses is a nearly constant 2 dB over the band. This corresponds to 1-dB output loss and, hence, 75% combining efficiency.

Large-signal measurements were also recorded, using a traveling-wave tube (TWT) amplifier to drive the array into compression. Two directional couplers were connected at both the input and output ports. Power sensors are connected to the couplers to measure the input and output power. The loss of this configuration is calibrated first, and power measurements are carried out at 10 GHz. As shown in Fig. 14, the 16-tray system generated 1-W CW power at the 1-dB compression point. Using a nominal output power of 16 dBm for each MMIC, this translates to a measured combining efficiency of 80% at this frequency, which is in good agreement with previous estimates based on system loss.

The power-frequency response was characterized from 4 to 15 GHz using a fixed input power of 20 dBm. This is shown in Fig. 15, and again follows the expected power gain curve

of the MMIC, indicating that the bandwidth of the system is determined by the MMIC. 29–30-dBm output power is reached in most of the band.

VI. CONCLUSION

Both passive and active coaxial waveguide power combiners have been analyzed and measured. Optimized broad-band transition designs based on SDM analysis have shown good agreement with the Agilent HFSS simulation result and measurements. A good impedance match is achieved from 3.5 to 18 GHz. The system has a capacity of integrating as many as 64-MMIC power amplifiers. A 32-MMIC combiner system, which has 16 circuit cards, has been demonstrated and 1-W output power is obtained. The combiner also demonstrates low dispersion and good linearity property. This scheme combines the tapered slotline with solid-state devices well. Good efficiency and high output power can be achieved by the novel structure.

REFERENCES

- [1] N.-S. Cheng, P. Jia, D. B. Rensch, and R. A. York, "A 120-watt X-band spatially combined solid-state amplifier," *IEEE Trans. Microwave Theory Tech.*, vol. 47, pp. 2557–2561, Dec. 1999.
- [2] A. Alexanian and R. A. York, "Broadband waveguide-based spatial combiner," in *IEEE MTT-S Int. Microwave Symp. Dig.*, vol. 3, Denver, CO, June 8–13, 1997, pp. 1139–1142.
- [3] P. Jia, L.-Y. Chen, N.-S. Cheng, and R. A. York, "Design of waveguide finline arrays for spatial power combining," *IEEE Trans. Microwave Theory Tech.*, vol. 49, pp. 609–614, Apr. 2001.
- [4] P. Jia, Y. Liu, and R. A. York, "Analysis of a passive spatial combiner using tapered slotline array in oversized coaxial waveguide," in *IEEE MTT-S Int. Microwave Symp. Dig.*, vol. 3, Boston, MA, June 2000, pp. 1933–1936.
- [5] L. P. Schmidt and T. Itoh, "Spectral domain analysis of dominant and higher order modes in fin-lines," *IEEE Trans. Microwave Theory Tech.*, vol. MTT-28, pp. 981–985, Sept. 1980.
- [6] T. Itoh, "Spectral domain immittance approach for dispersion characteristics of generalized printed transmission lines," *IEEE Trans. Microwave Theory Tech.*, vol. MTT-28, pp. 733–737, July 1980.
- [7] D. M. Pozar, *Microwave Engineering*, 2nd ed. New York: Wiley, 1998.
- [8] R. W. Klopfenstein, "A transmission-line taper of improved design," *Proc. IRE*, vol. 442, pp. 31–35, Jan. 1956.



Pengcheng Jia (S'98) received the B.S. degree in electronics science and information system from Nankai University, Tianjin, China, in 1995, the M.S. degree in electronic engineering from Tsinghua University, Beijing, China, in 1998, and is currently working toward the Ph.D. degree in electrical and computer engineering at the University of California at Santa Barbara.

His current research involves the development of waveguide-based broad-band high-power spatial power combiners and power amplifiers using GaN

devices.



Lee-Yin Chen (S'98) received the B.S. degree in electrical engineering from the National Taiwan University, Taipei, Taiwan, R.O.C., in 1997, the M.S. degree in electrical engineering from University of California at Santa Barbara (UCSB), in 1999, and is currently working toward the Ph.D. degree at UCSB.

Her current research involves the development of waveguide-based spatial power combining in microwave frequency and high-frequency power-amplifier design.

Angelos Alexanian (S'92–M'93) received the B.S. degree (*summa cum laude*) from the Virginia Polytechnic Institute and State University, Blacksburg, in 1991, the M.S. degree from The University of Michigan at Ann Arbor, in 1993, and the Ph.D. degree from the University of California at Santa Barbara in 1997, all in electrical engineering. His doctoral dissertation concerned EM analysis of periodic structures using the finite-difference time-domain technique and development of broad-band spatial power-combining schemes.

From 1997 to 1999, he was with the M/A-COM Corporate Research and Development Group, during which time he was involved with 77-GHz automotive radar sensors and design and development in the areas of antennas, circuits, and packaging. Since 1999, he has been with the RF Micro Devices, Billerica, MA, where he currently designs RF integrated circuits (RFICs) for the digital cellular product line.



Robert A. York (S'85–M'89–SM'99) received the B.S. degree in electrical engineering from the University of New Hampshire, Durham, in 1987, and the M.S. and Ph.D. degrees in electrical engineering from Cornell University, Ithaca, NY, in 1989 and 1991, respectively.

He is currently a Professor of electrical and computer engineering at the University of California at Santa Barbara (UCSB), where his group is currently involved with the design and fabrication of novel microwave and millimeter-wave circuits,

high-power microwave and millimeter-wave amplifiers using spatial combining and wide-bandgap semiconductor devices, and application of ferroelectric materials to microwave and millimeter-wave circuits and systems.

Dr. York was the recipient of the 1993 Army Research Office Young Investigator Award and the 1996 Office of Naval Research Young Investigator Award.