

Homework Assignment #5 (version 2)

(Due: **Th 21 Nov 2019** / Please e-mail your work directly to ph118.homework@gmail.com)

I. AC coupling.

The source in the picture below provides an AC signal that I want to amplify, but I am trying to block a DC offset that is also present in V_S .

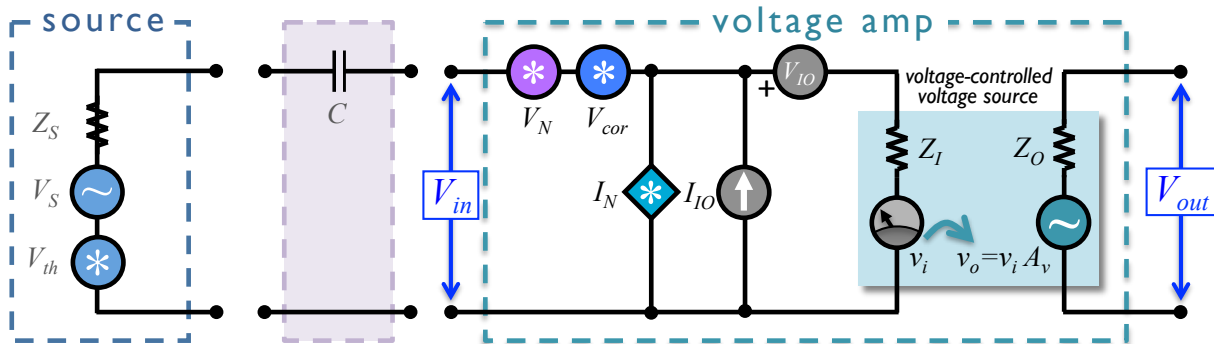

- If the AC signal I am interested is centered about a frequency ω_S , what value of capacitor should I use? (Please write your answer as a mathematical formula involving relevant parameters – include any necessary from the figure above.)
- Is the circuit topology I've proposed above adequate? If you believe some modification should be made, suggest the component(s) and its (or their) appropriate value(s). Please explain your reasoning.

2. Amplifier Total Harmonic Distortion (THD)

A sine wave with amplitude v and frequency ω , which we'll call the fundamental frequency, is applied to the input of a black box; its output is connected to a resistive load. Despite the single-tone input applied, a complex waveform emerges at its output (i.e., harmonics are generated).

Federal Standard 1037C and Military Standard MIL-STD-188 state that the total harmonic distortion (THD) of a signal is defined as the ratio of (i) the sum of the power carried by all harmonic frequencies above the fundamental frequency to (ii) the power carried by the fundamental frequency. (For some reason, the industry convention seems to interpret these standards as requiring them to determine THD using only the first five harmonics of the fundamental tone.)

- I'd like you to consider the simplest case involving nonlinearity. In class, I presented a power series expansion for the amplitude transfer function. Here, assume only three coefficients of that expansion for the black box – namely, α_1 , α_2 , and α_3 – are non-zero. Assume the aforementioned single tone, with amplitude v and frequency ω , is applied at the input. Derive a formula that relates THD (measured in dB) for this black box to the non-zero coefficients and v . Please show all of your work and explain your assumptions.
- If you can find them, Bryston 28B³ audiophile power amplifiers currently list for \$29,995 a pair. And you'll need a pair for stereo! (See: http://www.bryston.com/products/power_amps/28B-3.html)

A partial listing of their specs is as follows:

- **Power Output** (each channel): 1000 watts into 8Ω
- **Power Gain**: 29 dB
- **Distortion**: THD + Noise (THD+N) < 0.005% from 20Hz to 20kHz, at 1000 watts into 8Ω
- **Noise**, measured with input shorted (20Hz to 20 kHz): > 116dB below rated output

Questions:

- What is the magnitude of the r.m.s. noise power output?
- Assume the noise spectrum is white over the stated band. Using the specs above, estimate the voltage noise sqrt-spectral density referred to input (in units $nV/\sqrt{\text{Hz}}$). State all of your assumptions.
- What fraction of the “THD + N” spec arises from noise alone?
- Ascertain how much of the “Distortion THD + N” arises from distortion, and then assume that all of this distortion power arises entirely from the second- and third-order amplifier nonlinearities. Further assume that these two nonlinearities contribute equal (distortion) power to the output when the amplifier delivers its maximum rated power. What input voltage levels correspond to IIP2 and IIP3 for this amplifier?
- What type of amplifier noise is measured when the input is shorted? Why?

3. Simple model for a mixer.

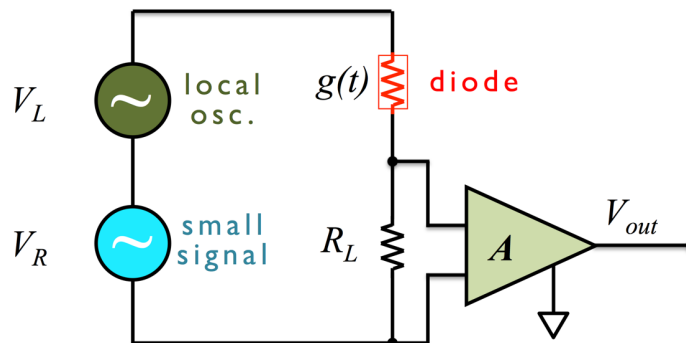

In class, I presented a simple model for a mixer. Is it really valid? Consider the alternative simple circuit pictured above. The two sources are ideal voltage sources; one is a large signal (local oscillator) at ω_L , and one is a small RF signal (“RF signal” = input) at ω_R . The output at “baseband” (the downmixed frequency product) is at ω_I . Model the diode using the ideal Shockley diode equation (use any source if you aren’t already familiar with it). Assume the small signal plays no role in modulating the diode conductance over time (i.e., because it is too small in comparison to the local oscillator waveform).

- Solve (or otherwise argue coherently for a representative answer) for V_{out} and confirm or disprove whether this circuit can serve as a mixer – that is, whether it can provide downconversion to a frequency $\omega_I = \omega_R - \omega_L$.
- Argue whether your answer is the same, or not, for sinusoidal and square wave local oscillator excitation. If you can, be quantitative in your argument.

4. “Mystery” mixer product.

In class, I showed the following mixer products arising from injection of a two-tone input signal with the following components/power:

$$\omega_A = 100 \text{ MHz @ +4 dBm}$$

$$\omega_B = 102 \text{ MHz @ +4 dBm}$$

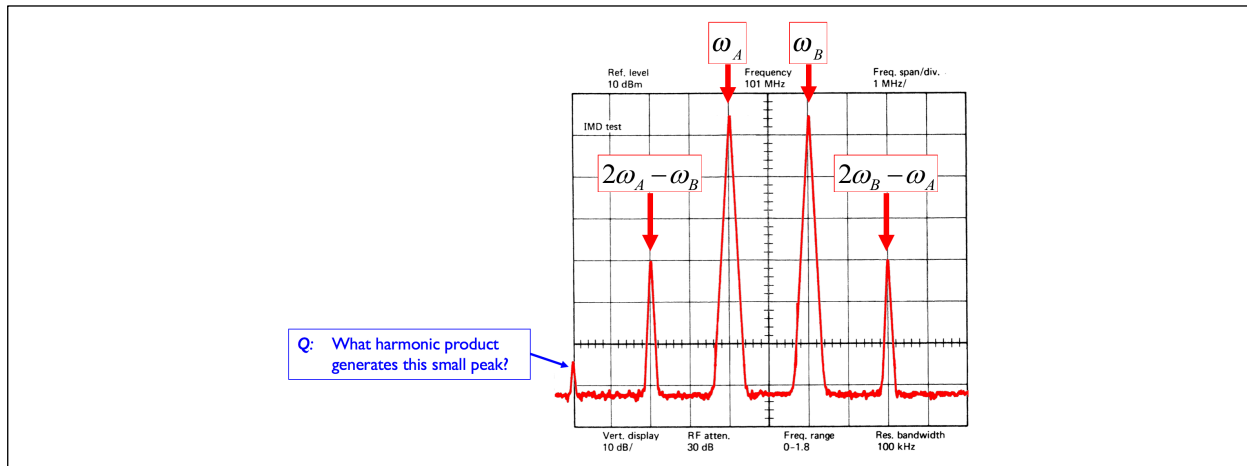

- What harmonic produce generates the small peak on the left?
- Can you argue why the relative power levels for all of the Fourier components shown are as shown?
 - Try to explain the ratio of the input waveforms to the $2\omega_A - \omega_B$, $2\omega_B - \omega_A$ products.
 - Qualitatively, try to explain the ratio of the input waveforms to the small peak.

5. Frequency Response and Dynamic Reserve with synchronous detection.

a) I stated in class that the lock-in amplifier topology can ultimately provide a bandpass response that is equivalent to that of a bandpass filter with a Q of several hundred thousand or beyond. Explain that statement in your own words and give a quantitative example that demonstrates it.

b) Despite this extremely narrow effective passband, I've nonetheless decided that I can further improve my system's dynamic reserve by putting a low- Q (say $Q \sim 10$) bandpass filter in front of the first stage of low-noise amplification. Why is this true? What are the possible drawbacks of implementing such a circuit topology?

6. Next term?

- Are you interested in participating in PhI 18b next term? **Y / N / maybe**
- If the answer to the above is “Y” or “maybe”, which topic(s) would you like the class to cover?
 - Continuation of topics in fundamental principles of measurement: e.g., spectrum & network analysis, S-parameters, time-domain measurements, software-designed instrumentation, grounding and shielding...
 - Measurement systems “clinic”: You would work with the prof on your own specific measurement challenges -or- pick one after joint discussion with him. Students will discuss their conceptual projects (progress & problems), and then make a final presentation to the class.
 - An admixture of i) and ii) above.