

75 GHz 80 mW InP DHBT Power Amplifier

Yun Wei, Miguel Urteaga, Zach Griffith, Dennis Scott, Shouxuan Xie, Vamsi Paidi, Navin Parthasarathy, Mark Rodwell

Department of Electrical and Computer Engineering, University of California
Santa Barbara, CA 93106, USA

Abstract — We report a 75 GHz MMIC power amplifier in InP/InGaAs/InP DHBT transferred-substrate technology. The amplifier has $256 \mu\text{m}^2$ total emitter area and exhibits a power gain of 5.5 dB at 75 GHz and a saturated output power of 19 dBm (80mW) under 1-dB gain compression. The DHBT employed by the amplifier has a lightly doped InP emitter epitaxial layer between the emitter and the emitter cap layer as a distributed ballast resistance to improve thermal stability. To our knowledge, this is the highest reported output power for a W-band HBT power amplifier.

I. INTRODUCTION

Millimeter-wave power amplifiers are key components for future mm-wave wireless data networks, automotive and military radars. To date, hetero-junction bipolar transistor (HBT) power amplifiers exhibit lower power levels than their HEMT counterparts [1] [2] [3] [4]. Addressing this discrepancy, we had earlier reported multi-finger InP DHBTs with 330 GHz f_{max} when biased at 100mA and 3.6 V [5], and had reported power amplifiers using this device exhibiting 40 mW saturated output power at 85 GHz [6]. Here we report a DHBT amplifier with record power output at W-band (75 GHz -110 GHz). The amplifier produced 80 mW output power at 75 GHz with 1-dB gain compression. The amplifier utilizes a modified DHBT layer structure incorporating a lightly doped InP epitaxial layer (LDE) in the emitter to increase the emitter access resistance, thereby improving thermal stability and preventing current filamentation within the individual HBT fingers.

II. DEVICE TECHNOLOGY AND CIRCUIT DESIGN

We had earlier reported wide bandwidth power hetero-junction bipolar transistors (HBTs) fabricated in a transferred-substrate technology which exhibited 330 GHz power gain cut-off frequency at 100mA collector current and 3.6V collector-emitter voltage [5]. These power HBTs were realized in a multi-finger topology.

Thermal stability of HBTs plays an importance role in power DHBT design [7], often producing a more serious limit on applied V_{ce} than the device breakdown

voltage. Addition of external emitter ballast resistances forces an equal partition of current between HBT fingers in a multi-finger device, but current filamentation can still arise within each individual HBT finger [8]. The latter effect can be suppressed by adding emitter resistance within the epitaxial layer structure [9] in the form of a lightly doped emitter layer (LDE). In this work, the layer structure, similar to [5], incorporates a 1000 Å InP layer with doping density of $N_{d_LDE}=5 \times 10^{16} \text{ cm}^{-3}$ between the emitter and the emitter cap layer.

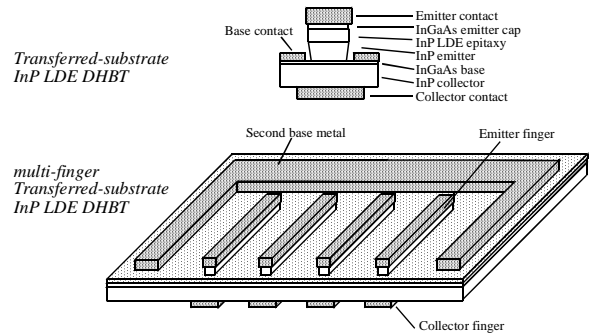

Figure 1 4-finger power DHBT in transferred-substrate technology with LDE InP epitaxy layer

Fig. 1 shows the diagram of the architecture of the multi-finger transferred-substrate DHBT (TS DHBT) with the LDE epitaxial layer. The dimension of the emitter finger is $1 \mu\text{m} \times 16 \mu\text{m}$ and is $2 \mu\text{m} \times 20 \mu\text{m}$ for the collector finger. To avoid electron velocity saturation effects, the LDE doping density is selected to satisfy $qN_{d_LDE}V_{\text{sat}} > J_{\text{max}}$, where J_{max} is the maximum desired current density, $1\text{mA}/\mu\text{m}^2$ in this design. For each emitter finger, the LDE layer provides 3.75Ω resistance, while the emitter ohmic contact provides 1.25Ω . A further 2.5Ω external NiCr resistance is provided for each finger to force equal currents between fingers. The device measurement shows f_{max} of 320 GHz at collector current of 60 mA and collector voltage of 3.2 V.

Fig. 2 shows the schematic of the MMIC power amplifier that employs the LDE TS DHBTs. The power amplifier is composed of four 4-finger common-base devices interconnected with T-section microstrip combiners. The combiners pre-match the low input and output impedances of the DHBTs, therefore easing the matching network design of the amplifier. The optimum admittance for saturated output power was obtained from the device DC I-V measurement by plotting a loadline with extrema of ($V_{ce}=1.5$ Volts, $I_c=260$ mA) and ($V_{ce}=7$ Volts, $I_c=0$ mA). A Π network followed by an impedance transformer reactively matches the output to the optimum load admittance. The long-arm input T-section with large bypass capacitors was designed to synthesize low Q value LC network. The input is then matched to 50Ω by an impedance transformer. The circuit was designed based on harmonic balanced simulation, using an in-house large signal model for multi-finger DHBTs. The model provides accurate simulations of both electrical and thermal characteristics. A full-wave electromagnetic (EM) simulation of passive circuits ensures the accuracy of the physical matching networks.

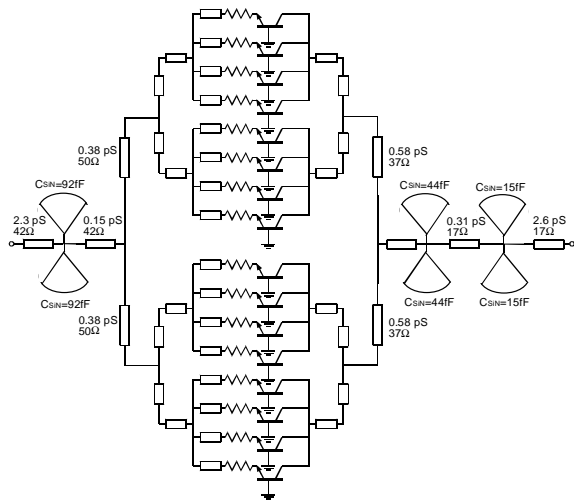

Figure 2 DHBTT MMIC power amplifier in transferred-substrate technology

Fig. 3 shows the die photograph of the MMIC DHBT power amplifier. The die area of the amplifier is $0.38 \text{ mm} \times 0.89 \text{ mm}$.

III. TESTING

Amplifier small-signal gains and return losses were measured on-wafer using GGB wafer probes and a W-band Agilent 8510 network analyzer calibrated with a commercial LRM substrate. For power measurements, the amplifiers were driven by either a W-band frequency multiplier and power amplifier or a W-band IMPATT, and the output power measured directly with a power meter without additional off-wafer load impedance tuning. The data is corrected for the measured attenuation of wave guides and wafer probes.

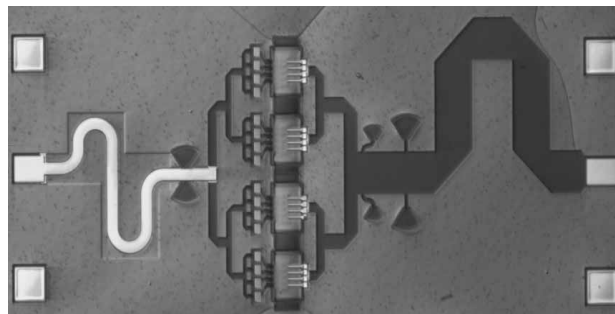

Figure 3 Die photograph of MMIC power amplifier in transferred-substrate technology

IV. RESULTS AND DISCUSSION

Fig.4 shows the measured small signal S-parameters of the amplifier in W-band frequencies. The data was taken at a collector current of 130 mA and collector-emitter voltage of 4.2 V of V_{CE} . The maximum power gain is 5.5 dB and the input return loss is less than 10 dB at 75 GHz. As with all power amplifiers, the low power gain is a result of tuning the output for maximum saturated output power, rather than maximum small-signal gain. For the same reason, S_{22} is nonzero at the operating frequency.

Fig.5 shows the power measurement results of the amplifier at 75GHz. The power amplifier exhibits 19 dBm (80 mW) output power with 1-dB gain compression, which is the highest output power reported for HBT amplifiers operating at this frequency. The peak PAE of 8% occurs at the output power of 18 dBm (63 mW).

The LDE epitaxial layer forces a uniform the current density within each DHBT finger, preventing premature occurrence of the Kirk effect [3] and associated bandwidth collapse under high power density bias conditions.

ACKNOWLEDGEMENT

This work is supported by the ARO-MURI program (lead institution: California Institute of Technology) under contract number PC249806.

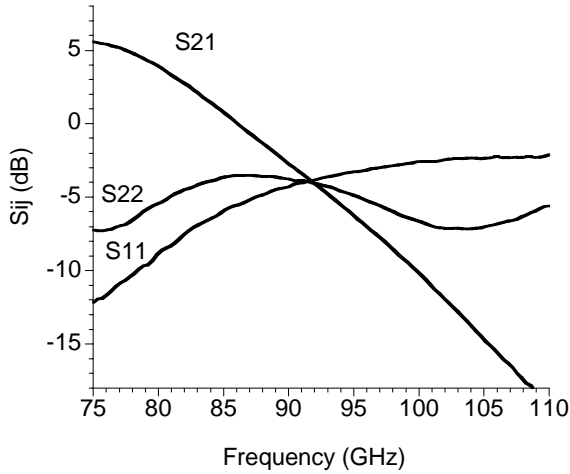

Figure 4 Small signal S-parameter measurements in W-band frequencies

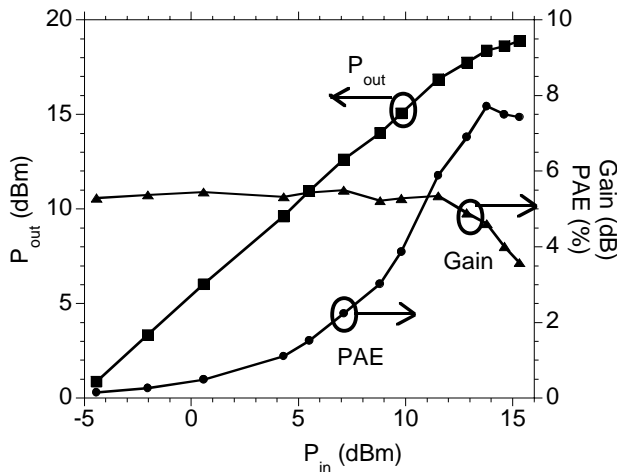

Figure 5 Power measurements at 75 GHz

V. CONCLUSION

We have demonstrated a monolithic W-band power amplifier based on a 1 μm InP/InGaAs/InP transferred-substrate DHBT. The amplifier produced 80 mW output power at 75 GHz with 1-dB gain compression, which is the record power level for DHBTs in W-band. By using an effective distributed emitter ballasting scheme with a lightly doped emitter epitaxial layer, a transistor emitter junction areas can be increased to directly achieve high output power in W-band frequencies.

REFERENCES

- [1] Huei Wang; Samoska, L.; Gaier, T.; Peralta, A.; Hsing-Hsing Liao; Leong, Y.C.; Weinreb, S.; Chen, Y.C.; Nishimoto, M.; Lai, R. "Power-amplifier modules covering 70-113 GHz using MMICs". IEEE Transactions on Microwave Theory and Techniques, vol.49, (no.1), IEEE, Jan. 2001. p.9-16.
- [2] Chen, Y.C.; Ingram, D.L.; Lai, R.; Barsky, M.; Grunbacher, R.; Block, T.; Yen, H.C.; Streit, D.C. "A 95-GHz InP HEMT MMIC amplifier with 427-mW power output". IEEE Microwave and Guided Wave Letters, vol.8, (no.11), IEEE, Nov. 1998. p.399-401.
- [3] Huang, P.; Lin, E.; Lai, R.; Biedenbender, M.; Huang, T.W.; Wang, H.; Geiger, C.; Block, T.; Liu, P.H. "A 94 GHz monolithic high output power amplifier". 1997 IEEE MTT-S International Microwave Symposium Digest, Denver, CO, USA, 8-13 June 1997. New York, NY, USA: IEEE, 1997. p.1175-8 vol.3.
- [4] Guthrie, J.R.; Urteaga, M.; Scott, D.; Mensa, D.; Mathew, T.; Lee, Q.; Krishnan, S.; Jaganathan, S.; Betsler, Y.; Rodwell, M.J.W. "HBT MMIC 75 GHz and 78 GHz power amplifiers." Proceedings of 2000 International Conference on Indium Phosphide and Related Materials, Piscataway, NJ, USA: IEEE, 2000. p.246-2499
- [5] Yun Wei, Sangmin Lee, P.K. Sundararajan, Mattias Dahlstrom, Miguel Urteaga, Mark Rodwell. "High current (100mA) InP/InGaAs/InP DHBTs with 330 GHz f_{max} ." Proceedings of Indium Phosphide and Related Materials Conference, Stockholm, Sweden, May 12-16, Piscataway, NJ, USA: IEEE, 2002. p.47-50
- [6] Yun Wei, Sangmin Lee, Krishnan Sundararajan, Mattias Dahlstrom, Miguel Urteaga, Mark Rodwell. "W-band InP/InGaAs/InP DHBT MMIC Power Amplifiers." Proceedings of IEEE MTT-S International Microwave Symposium, Seattle, WA, June, 2002, Piscataway, NJ, USA: IEEE, 2002. p.917-20 vol.2.
- [7] W. Liu, "Failure mechanism in AlGaAs/GaAs hetero-junction bipolar transistors", IEEE Trans. Electron Devices, vol.43, Feb. 1995
- [8] William Liu, "Handbook of III-V hetero-junction bipolar transistors", "A Wiley-Interscience publication", ISBN 0-471-249041, 1998.
- [9] Chen, M.; Nguyen, C.; Liu, T.; Rensch, D. High-performance AlInAs/GaInAs/InP DHBT X-band power cell with InP emitter ballast resistor. Proceedings. IEEE/Cornell Conference on Advanced Concepts in High Speed Semiconductor Devices and Circuits, Ithaca, NY, USA, 7-9 Aug. 1995